

PC Series™ Precision Linear Actuators

Optimized Machine Design and Energy Savings Through Reliable,
High-Performance and Compact Electric Actuation

Unmatched Power Density, Speed and Stroke Length

Thomson PC Series™ electric actuators are designed to deliver superior performance as they are stronger, faster and longer-reaching than other comparable units on the market. The PC Series offers a broad range of accessories and options, including servo motors, making them ideal for virtually any application.

Exceptional Power Density

- Provides market-leading load capabilities
- Allows you to downsize your equipment
- Helps extend the actuator's operating life

Higher Speed

- Reduces the overall machine cycle time
- Allows for seamless integration with other high-speed machinery and processes
- Enables electric actuation in new machine axes and applications

Longer Stroke Length

- Provides solution for hard-to-reach places
- Gives greater freedom in the mounting position
- Covers larger areas in scanning, cutting and measuring applications

Key Attributes:

- **Large-diameter ball screw**
- **Optimized thrust bearing**
- **Unique carrier design**
- **Large-diameter extension tube in relation to the compact envelope**



Unmatched Travel Life

The PC Series offers unmatched travel life, delivering up to four times more travel distance than comparable competitive actuators due to its larger, high-precision ball screw assembly. In other words, you can make it from Rome to London with the competition, but you will go all the way to Chicago with the PC Series.

Ball Screw Diameter vs. Load and Travel Life

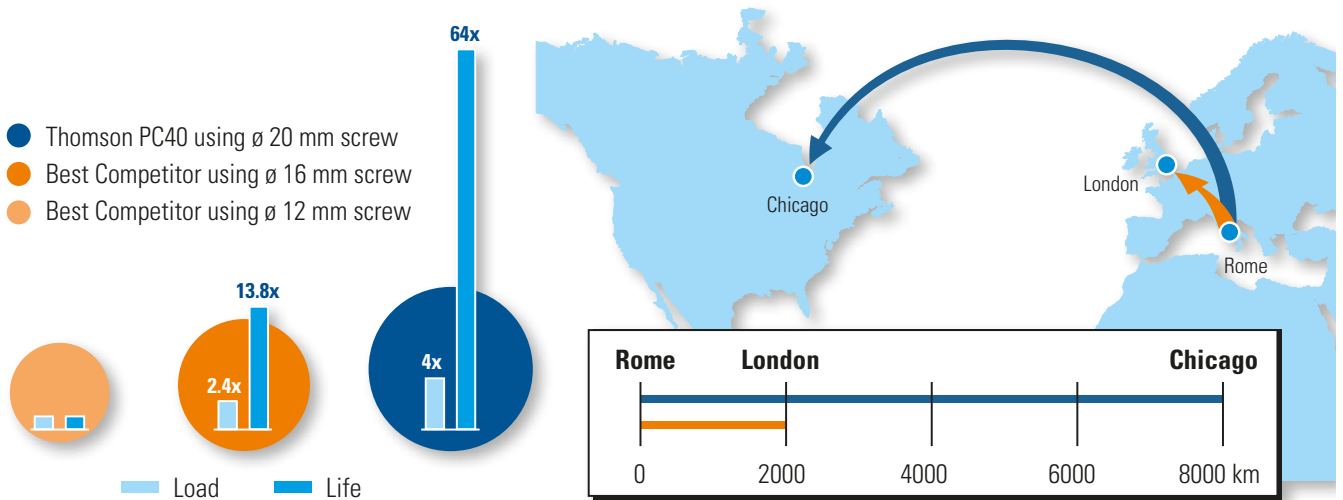

Best In Class

The PC Series outperforms the competition in almost every area. The diagram below compares the PC40 performance to its key competitors.

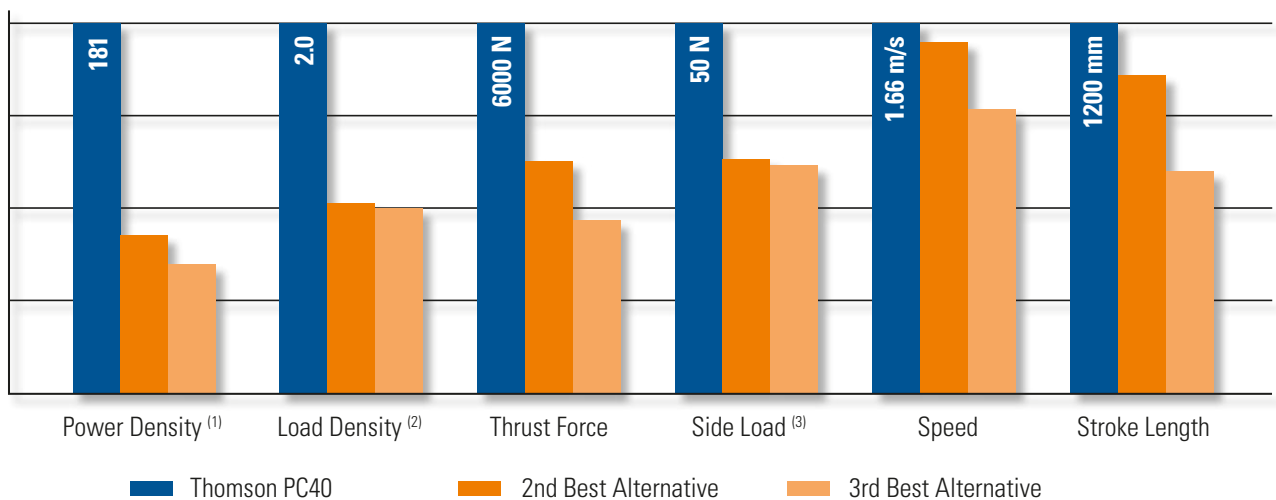

1) Power Density is defined as the maximum permissible force and speed compared to the frame size

2) Load Density is defined as the maximum permissible force compared to the frame size

3) Side Load capacity is for fully extended tube at the maximum available stroke length for the actuator in question

Make the Change to Electric

Next-generation machines and equipment need to be more compact while delivering higher performance and increased flexibility. Making the change from pneumatic cylinders to electric actuators can simplify your design and deliver savings at the same time.

Superior Performance

- Higher power density
- More accuracy
- Longer stroke lengths
- Quieter operation
- Side load capability

Time and Energy Savings

- Reduced energy costs
- Reduced setup and changeover time
- Fewer components than a pneumatic system
- No air leaks
- No compressor maintenance

Electric vs. Pneumatic Design		
	Electric	Pneumatic
Controllability	★ ★ ★ ★	★ ★
Load	★ ★ ★	★ ★
Accuracy	★ ★ ★ ★	★
Speed	★ ★ ★	★ ★ ★ ★
Maintenance	★ ★ ★	★
Noise	★ ★ ★	★ ★
Installed Cost	★ ★	★ ★ ★ ★
Operating Cost	★ ★ ★ ★	★
Total Cost	★ ★ ★	★ ★

Estimate Your Annual Energy Savings

Visit www.thomsonlinear.com/pc_calc to see how much you could save with the PC Series.

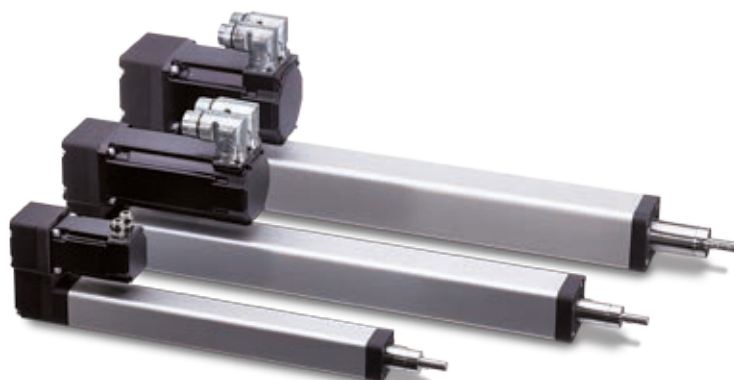

Save on Design, Installation and Operating Time

The Thomson PC Series has been designed and built to save you time at every step, from selecting your actuator all the way through reducing maintenance.

Easy to Size & Select

- Size and select your PC Series actuator in less than 15 minutes using online selection tools
- Download configurable 3D CAD models in a vast range of formats
- Customize your solution (length, motor orientation, mounting adapters and screw leads)



Online selection tool

Quick and Reliable Installation

- Install in less than five minutes with the Thomson RediMount™ motor mounting system
- Use your own motor! RediMount is pre-engineered for more than 600 different motor types and sizes
- Reduce time spent aligning the actuator and motor with the RediMount pre-aligned solution
- Easily upgrade your machine from pneumatics utilizing the PC Series ISO standard mounting interfaces

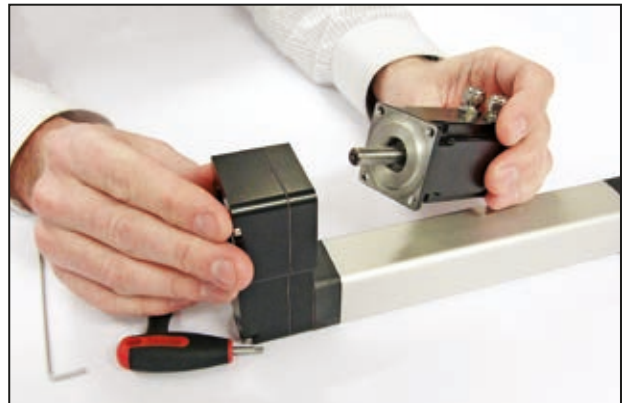

The RediMount system makes motor mounting fast and easy

Reduced Maintenance

- Quick and effective washdowns due to streamlined profile and IP65 rating
- Quickly prepare actuator for lubrication by advancing to fully retracted position
- Corrosion resistant throughout
- Longer life due to high power density and ability to compensate for system misalignment



Designed to withstand the harshest conditions

Get Your PC Series with a Suitable Motor

- All PC Series sizes and models are available with suitable Kollmorgen AKM servo motors
- Reduce time spent on the motor sizing and selection process
- Get a fully assembled and tested motor and actuator package directly from the factory
- Take advantage of the full range of matching servo drives and controls from Kollmorgen

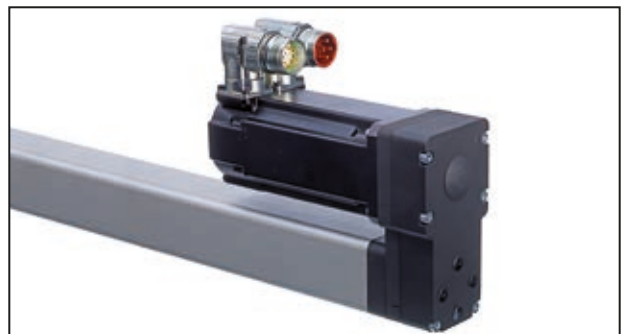

Get a complete actuator and servo motor package

PC Series™ – Designed to Deliver Value

The design of a PC Series precision linear actuator delivers extended life, high repeatability and quiet operation. In addition, it requires minimal maintenance and resists corrosion in harsh environments.

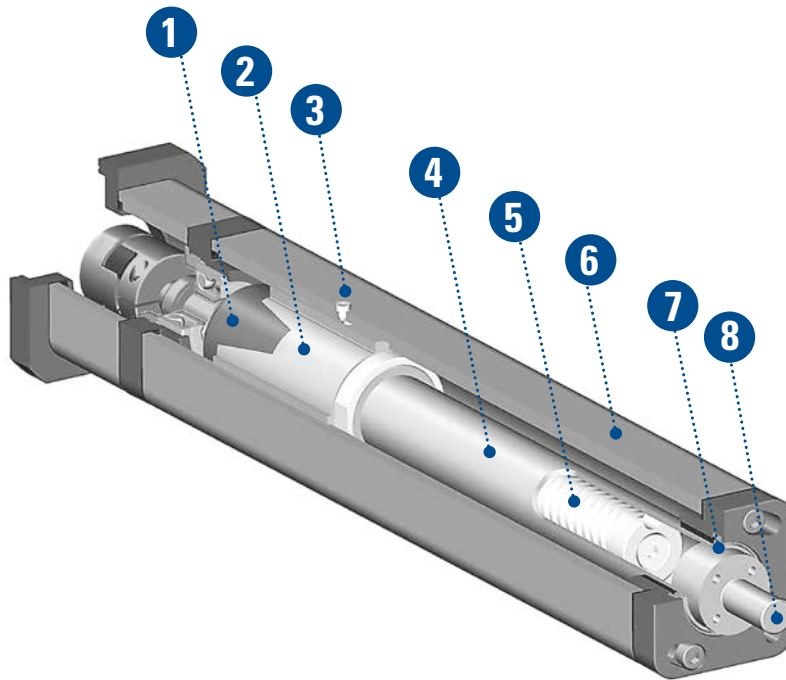

	Feature	Benefit
1	High precision ball nut	High repeatability and positioning accuracy Smooth, quiet operation
2	Ball nut carrier (US patent pending)	High side load capability Reduced noise Built-in anti-rotation of rod end
3	Single point lubrication	Quick and easy maintenance
4	Stainless steel extension tube	Suitable for heavy loads and harsh environments
5	Large diameter ball screw	High power density and long life
6	Smooth exterior profile	No collection points during washdown
7	Extension tube seal	IP65 rating suitable for harsh environments
8	Stainless steel male rod adapter	Corrosion resistance Simple mounting of ISO standard accessories

RediMount™ – Designed for Flexibility and Speed

The RediMount system is designed for seamless motor installation in less than five minutes. It accommodates a wide range of motor types and sizes. Motor-to-actuator alignment is guaranteed, ensuring a trouble-free connection and maximum system performance.

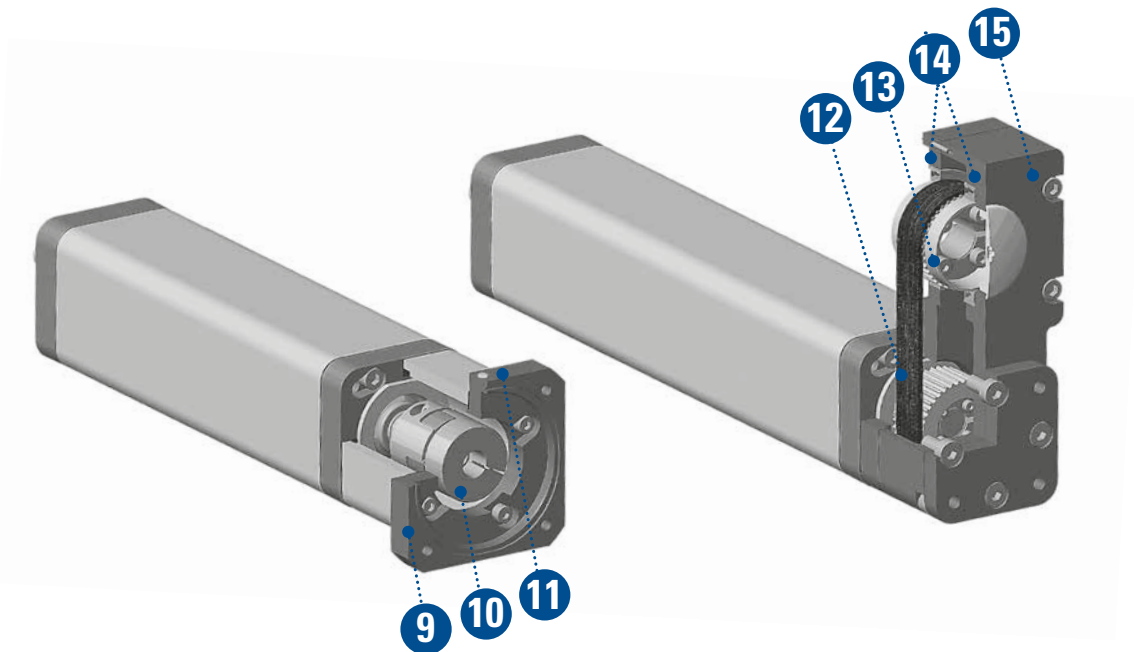

	Feature	Benefit
9	Thomson RediMount motor flange	Mounting in less than five minutes Pre-engineered to mount to more than 600 motors
10	Large, flexible coupling	High torque
11	Sealing plug	IP65 protection
12	Extra-wide synchronous belt	High thrust loads
13	Clamping element	Plug-and-play motor assembly
14	Straddle-mounted pulley bearings	No radial load on motor shaft
15	Large housing	Accommodates large frame motors

RediMount Motor Mounting Steps



Insert motor shaft into coupling



Tighten motor mounting screws



Tighten motor coupling screws and install sealing plug

Build Flexibility into Your Processing Application

The complexities of many processing applications, including sanitary washdown requirements and mixed product manufacturing lines, are easily accommodated by the Thomson PC Series™ precision linear actuators which are IP65 rated as standard.

Form, Fill and Seal Equipment

Filling heads move up and down rapidly and repeatedly on form, fill and seal equipment. Electric actuators provide an advantage with higher precision and repeatability than a pneumatic solution.



Grading

Sorting arms and pushers move to shift product into distinct bins in grading applications, often a consolidation point from many production lines. The predictable life of electric actuators ensures that the line will stay up as intended between maintenance cycles.



Converting and Container Manufacturing

Molding, can and box manufacturing equipment often require several axes to move and operate in confined spaces in close proximity to each other. By using electric actuators instead of pneumatic cylinders, you can save space and installation time while improving the accuracy of the process.



Inspection

Testing tightening torque and checking seals is essential to overall product quality. Electric actuators provide superior accuracy and repeatability at this critical step.



Accelerate Your Packaging or Handling Application

Packaging and handling processes require speed to keep up with ever-increasing flow rates from manufacturing lines. Higher speed does not have to mean higher energy consumption. Choosing Thomson PC Series electromechanical linear actuators can greatly reduce energy consumption due to the fact that they use energy on demand.

Marking and Printing

Product quality and traceability are growing in importance as regulations become more strict. Consistently placing the right label on the right package in the right position is more critical than ever. In addition, electric actuators are an ideal choice for the end of the manufacturing line, where labels and printing often take place but no air lines may be present.



Secondary Packaging

Automation is increasing at the end of the line, where products are wrapped, cartoned, strapped, banded, and palletized for shipment. The higher load capability of electric actuators enables more compact machine designs that take up less floor space.



Conveying, Sorting and Pick and Place

Ensuring that the product is at the right place at the right time is an essential part of running an automated manufacturing line, but the product coming down the line can vary. When requirements change, electric actuators allow you to change the end stop and fence positions on your line quickly with a program change, instead of a redesign and cylinder change.



Automated Storage and Retrieval

High duty cycles and harsh environments are common in automated storage and retrieval systems. Reduce maintenance needs and downtime while consuming less energy when you choose electric actuators instead of pneumatics.



How to Size and Select Your PC Series™ Actuator

There are two ways to determine the suitable PC Series actuator for your application. Either you can use this catalog or you can use our downloadable and easy-to-use PC Series Sizing and Selection tool.

Using the Catalog

The catalog will guide you through the basic selection process based on your own calculations and choices.

1. Start by determining the suitable size of the actuator for your application by looking at the Product Family Overview on page 12.
2. Use the performance diagrams on the corresponding actuator specifications page to get an idea of expected life of the actuator and that it meets critical speed as well as column load based on your application details.
3. Go to the corresponding actuator dimensions page and select inline or parallel style based on your preference. Review the tables to the right and make sure that your motor and/or gear dimensions are compatible with the actuator.
4. Go to the ordering key on page 32 and follow the steps on how to order your actuator.

To select your actuator together with a pre-defined Kollmorgen AKM servo motor follow the steps on page 11.

Using the PC Series Sizing and Selection Tool

The Sizing and Selection tool will give you more help and control and will perform the necessary calculations based on your input.

1. Download the Sizing and Selection tool at www.thomsonlinear.com/pcseries under the tab Literature in section Calculation Support.
2. Enter your application data in four easy steps into the tool and you will get detailed information of which actuator suits your specific application as well as the expected life time and a fully configured part number ready to order.
3. The tool will also give you the option to choose between the many pre-defined motors or size and select a motor by entering your own preferred motor data.

A recorded introduction on how to use the tool can be found here: www.thomsonlinear.com/website/com/eng/support/training_webinars.php.

How to Add an AKM Servo Motor to Your Actuator

If you don't want to spend time on the sizing, selection and mounting of motors, you can order your PC Series actuator with a suitable premounted and tested AKM Servo Motor.

Selecting a Suitable Motor Using the Catalog

1. Start by determining the suitable size of the actuator for your application by looking at the Product Family Overview on page 13.
2. Use the performance diagrams on the corresponding actuator specifications page to get an idea of expected life of the actuator and that it meets critical speed as well as column load based on your application details.
3. Next, determine your available input voltage (1-phase 120 VAC, 1-phase 240 VAC or 3-phase 400 VAC).
4. Select the corresponding diagram(s) for your voltage to review which curve best suits the needs based on the required speed and load. The color coding of the curves determine the different available screw leads for the actuator type, while the type of curve (solid/dotted) show the duty cycle zones for the different leads.

5. Study the tables on the left page of the diagrams. They show the base ordering code of the actuator, the complete model number of the motor and dimensions for the combination. Use this information and the lead size you obtained from the diagram to determine the full ordering code for the actuator to be able to place an actuator and motor order.

Definition of Duty Cycle Zones

Continuous operation (solid line) = in this zone you are able to run the unit at 100% duty cycle.

Intermittent operation (dotted line) = operation in this zone should be limited to a duty cycle that will produce an RMS load that falls within the continuous zone. The RMS value is a function of the intermittent load and the time spent at that load.

The above will be taken under consideration if using The Sizing and Selection tool.

Using the Sizing and Selection Tool

The Sizing and Selection tool will help you through the whole process, motor selection included, and presents more alternatives than the catalog.

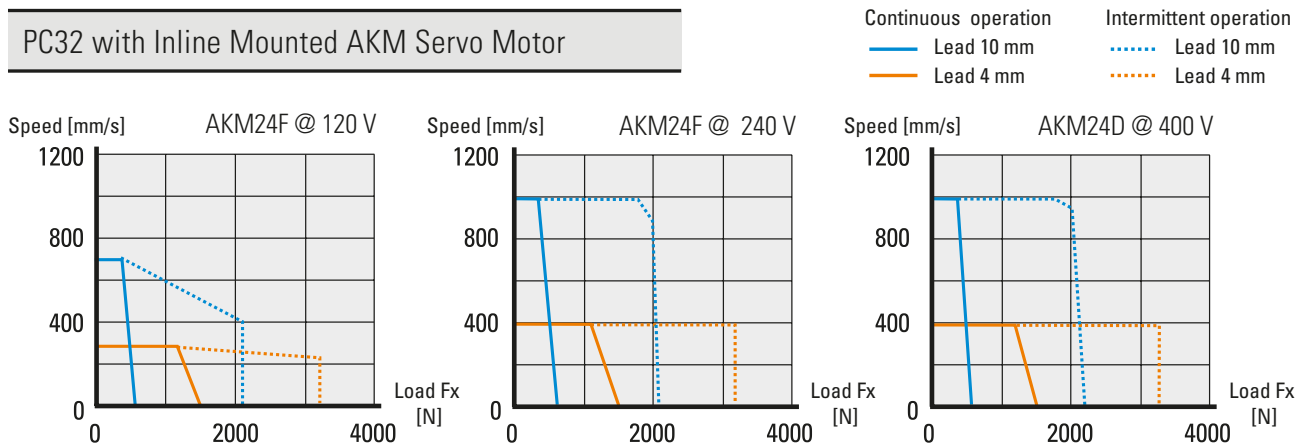

Product Family Overview - Without Motors

The PC Series is available in three sizes (PC25, PC32 and PC40) and two styles (inline and parallel). A complete line of accessories is available to make the mounting of the units simple, fast and safe.

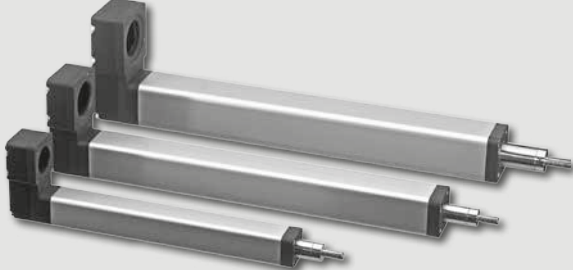
Family Overview - without Motors				
Inline Style		Parallel Style		
				
		PC25	PC32	PC40
Screw Type		ball screw		
Max. Load (Fx)	[N]	1250	3200	6000
Max. Stroke	[mm]	600	1200	1200
Max. Speed	[m/s]	1.33	1.00	1.66
Profile Size	[mm]	34 × 34	45 × 45	55 × 55
Screw Diameter	[mm]	10	12	20
Screw Lead	[mm]	3, 10	4, 10	5, 10, 20
Protection Class		IP65		

Accessories

A complete line of accessories is available, including ISO-compatible actuator mounting options, extension tube adapters and limit sensors. See pages 26 - 31.

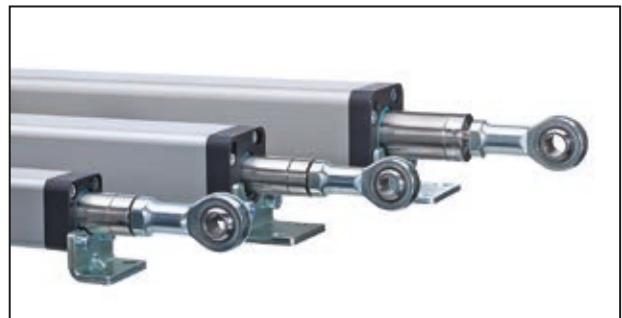

Product Family Overview - With AKM Servo Motors

All PC Series sizes, in both inline and parallel styles, are available with AKM servo motors that comes mounted and tested from the factory. They share the same specifications and performance as the motorless models unless stated otherwise below.

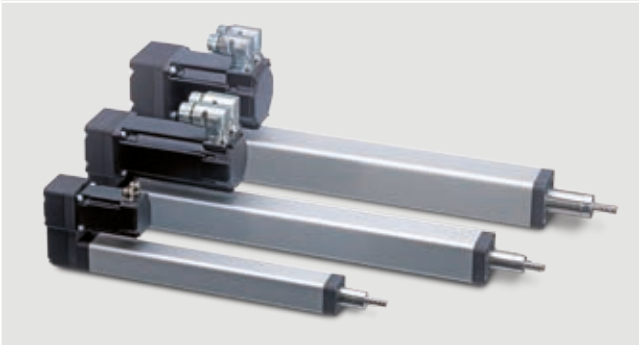
Family Overview - with AKM Servo Motors			
Inline Style		Parallel Style	
			
		PC25	PC32
Motor Type		brushless AC synchronous servo motors	
Max. Load (Fx)	[N]	1250	3200
Motor Feedback Type, Standard (Optional)		resolver (single turn encoder/multi turn encoder)	
Motor Fail Safe Holding Brake, Standard (Optional)		no (yes)	
Motor Connection of Power and Feedback Cables		AKM1xx: 0.5 m flying cables with connectors AKM2(3/4)xx: rotatable motor housing mounted connectors	
Motor Protection Class, Standard (Optional)		AKM1xx: IP40 (IP65, IP67), AKM2(3/4)xx: IP54 (IP65, IP67)	

AKM Servo Motors

Kollmorgen AKM is a well-known, high-quality motor range, which is complemented by a vast range of servo drives and programmable positioning controllers for both single and multi-axis applications. Some of the benefits include:

- Best-in-class performance with industry-leading power density
- Exceptionally low cogging and harmonic distortion to ensure smooth performance
- Easy to commission and use with plug-and-play motor recognition and full-frequency auto-tuning on AKD™ Series servo drives



Learn more about AKM Servo Motors at:

www.kollmorgen.com

Specifications - PC25



Standard Features and Benefits

- Compact, robust and reliable
- Stroke up to 600 mm
- Load up to 1250 N
- Speed up to 1.33 m/s
- Stainless steel extension tube
- IP65 as standard
- Mounting accessories according to pneumatic ISO standard

General Specifications

Parameter	PC25
Profile size (w × h) [mm]	34 × 34
Type of screw	ball screw
Protection class	IP65
Lubrication	one point lubrication of ball screw

Performance Specifications

Parameter		PC25
Stroke length (S max), maximum	[mm]	600
Linear speed, maximum	[m/s]	1.33
Acceleration, maximum	[m/s ²]	10
Repeatability	[± mm]	0.01
Input speed, maximum	[rpm]	8000
Operation temperature limits	[°C]	-20 – +70
Dynamic load (F _x), maximum	[N]	1250
Dynamic load (F _y), maximum	[N]	20
Dynamic load (F _z), maximum	[N]	20
Dynamic load torque (M _z , M _y), maximum	[Nm]	10
Screw versions, diameter (d ₀) / lead (p)	[mm]	10/03, 10/10
Drive shaft force (F _{rd}), maximum	[N]	100
Input torque, maximum (RediMount models)	[Nm]	2.3
Drive shaft torque (M _{ta}), maximum	[Nm]	4.0

Definition of Forces

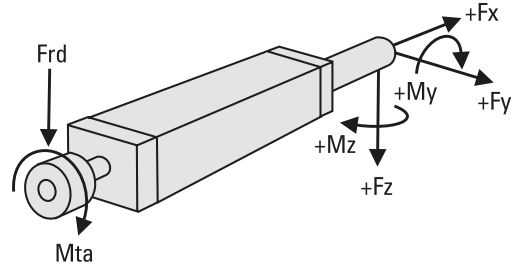

Performance Diagrams

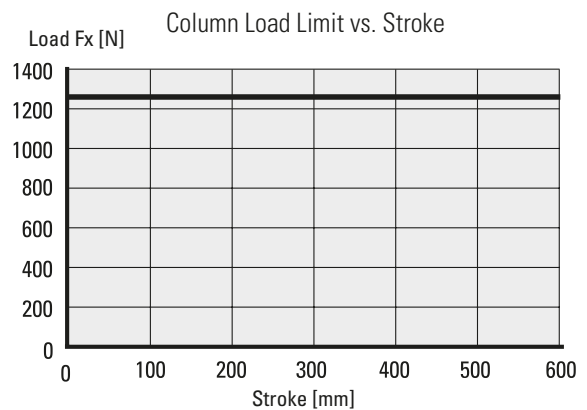
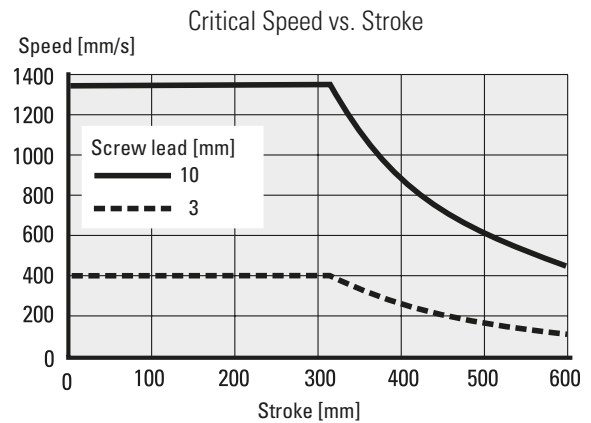
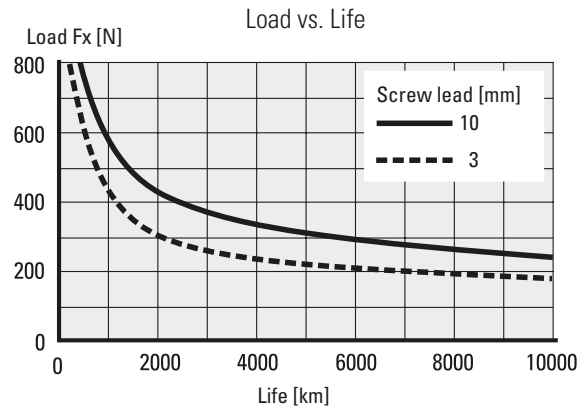

Dimensions - PC25

Dimensions for Inline Style with RediMount Flange

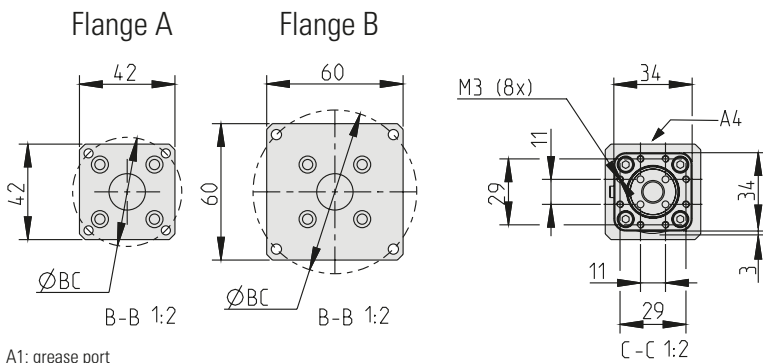
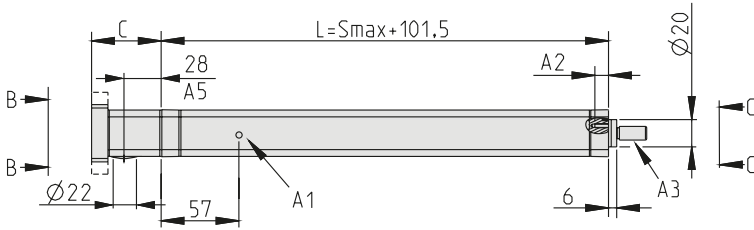

- A1: grease port
- A2: M3 thread, max. depth 10 mm.
- A3: male threaded rod end shown, see ordering key and accessories for information on all available ends.
- A4: side of cover tube for mounting of sensors.
- A5: distance to center of coupling tightening hole.

Dimensions	Projection
METRIC	

Bell House Length (C)	
Motor shaft length [mm]	C [mm]
19 - 24	52
24 - 29	57
29 - 34	62
34 - 39	67

RediMount Flange Motor Dimensions Compatibility*		
Motor data	Flange A [mm]	Flange B [mm]
Bolt circle diameter (BC)	43.8 - 48	48 - 72
Shaft diameter	5 - 11	
Shaft length	19 - 39	
Pilot diameter	16 - 36	16 - 54
Pilot length	max. 4	

Weight of Unit [kg]
0.543 + (S [mm] × 0.0021)

Dimensions for Parallel Style with RediMount Motor Flange

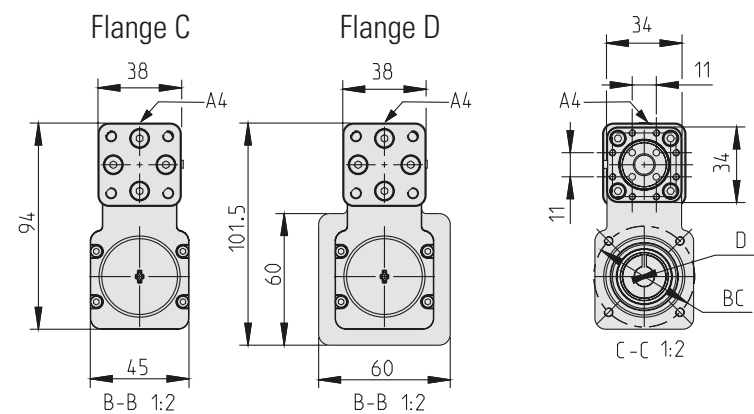
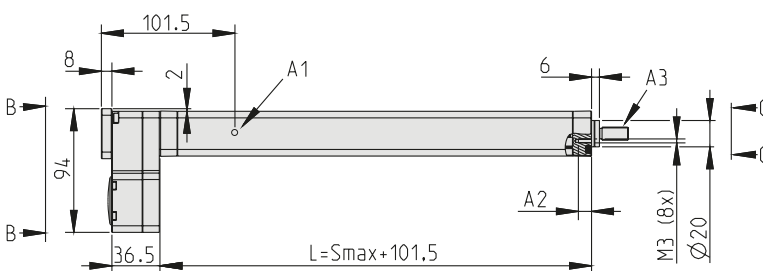

- A1: grease port
- A2: M3 thread, max. depth 10 mm.
- A3: male threaded rod end shown, see ordering key and accessories for information on all available ends.
- A4: side of cover tube for mounting of sensors.

Dimensions	Projection
METRIC	

RediMount Flange Motor Dimensions Compatibility*		
Motor data	Flange C [mm]	Flange D [mm]
Bolt circle diameter (BC)	25 - 51	51 - 72
Shaft diameter	5 - 10	
Shaft length	13 - 35	
Pilot diameter	16 - 39	16 - 54
Pilot length	max. 4	
Motor square/diameter	max. 66.5	

Weight of Unit [kg]
0.778 + (S [mm] × 0.0021)

* The Dimensions Compatibility tables only take motors/gears with through-hole face mount under consideration. Contact Customer Service for compatibility information for motors /gears with threaded hole face mount.

Specifications - PC25 with AKM Servo Motors

PC25 with Inline Mounted AKM Servo Motor						
Unit Type	Motor Model*	RediMount Flange Type	Bell House Length (C) [mm]	Motor Length (Lmotor) [mm]	Motor Square Size (Msq) [mm]	Total Weight of Unit with Flange and Motor [kg]
PC25LX367B	AKM13C-ANCNR-00	A	57	107.6	40	$0.63 + 0.543 + (S \text{ [mm]} \times 0.0021)$
PC25LX004B	AKM24F-ANBNR-00	B	52	143.2	58	$1.66 + 0.543 + (S \text{ [mm]} \times 0.0021)$
PC25LX004B	AKM24D-ANBNR-00	B	52	143.2	58	$1.66 + 0.543 + (S \text{ [mm]} \times 0.0021)$

* Motors listed have no brake and are equipped with resolver. Other motor models may have different dimensions and weight.

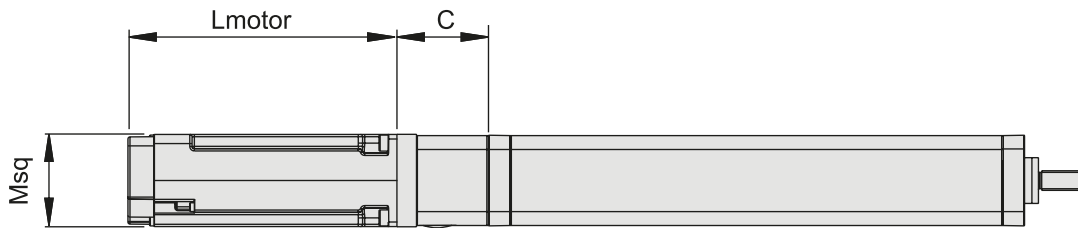

PC25 with Parallel Mounted AKM Servo Motor						
Unit Type	Motor Model*	RediMount Flange Type	Bell House Length (C) [mm]	Motor Length (Lmotor) [mm]	Motor Square Size (Msq) [mm]	Total Weight of Unit with Flange and Motor [kg]
PC25PA367B	AKM13C-ANCNR-00	C	–	107.6	40	$0.63 + 0.778 + (S \text{ [mm]} \times 0.0021)$
PC25PA004B	AKM24F-ANBNR-00	D	–	143.2	58	$1.66 + 0.778 + (S \text{ [mm]} \times 0.0021)$
PC25PA004B	AKM24D-ANBNR-00	D	–	143.2	58	$1.66 + 0.778 + (S \text{ [mm]} \times 0.0021)$

* Motors listed have no brake and are equipped with resolver. Other motor models may have different dimensions and weight.

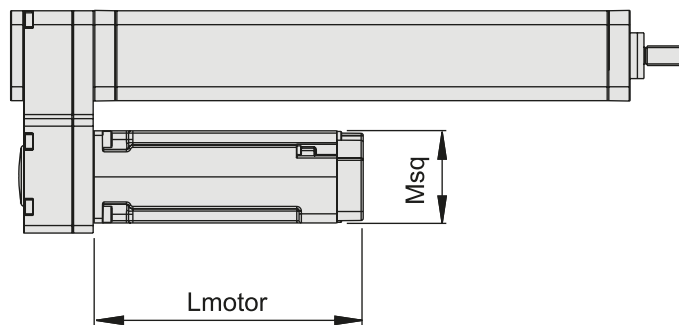

Performance Diagrams - PC25 with AKM Servo Motors

PC25 with Inline Mounted AKM Servo Motor

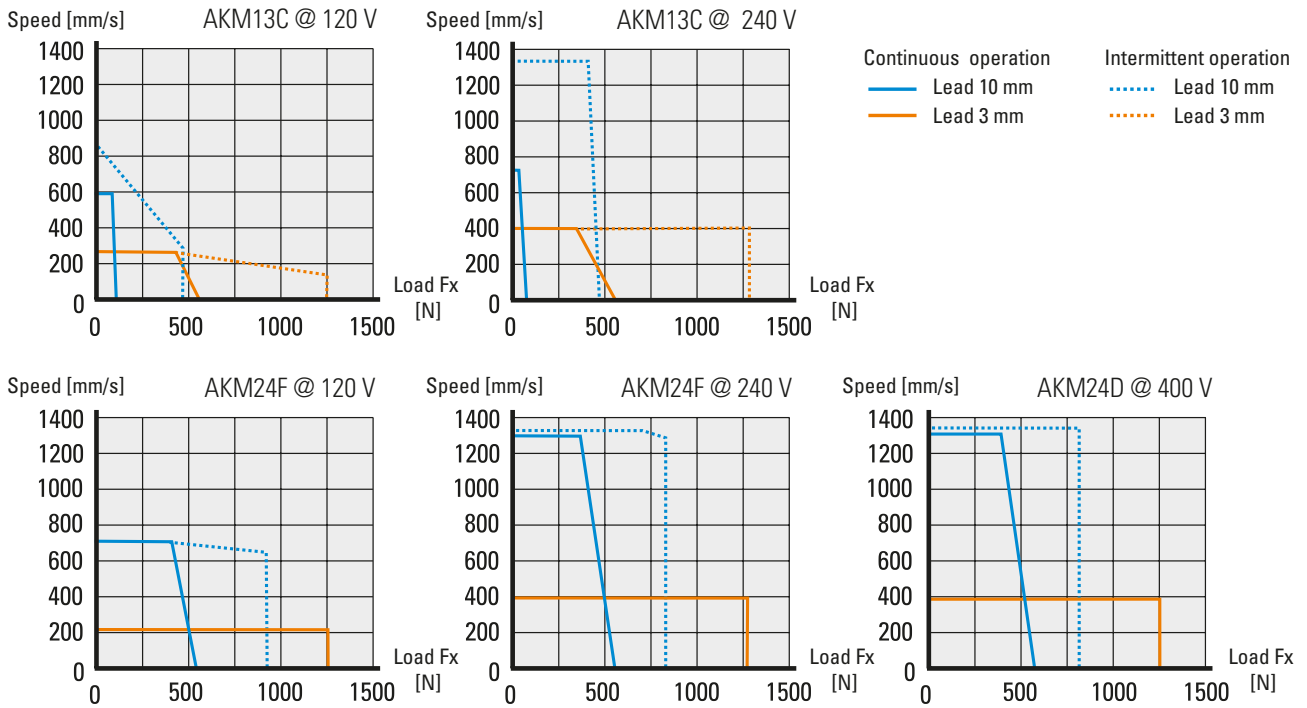

PC25 with Parallel Mounted AKM Servo Motor

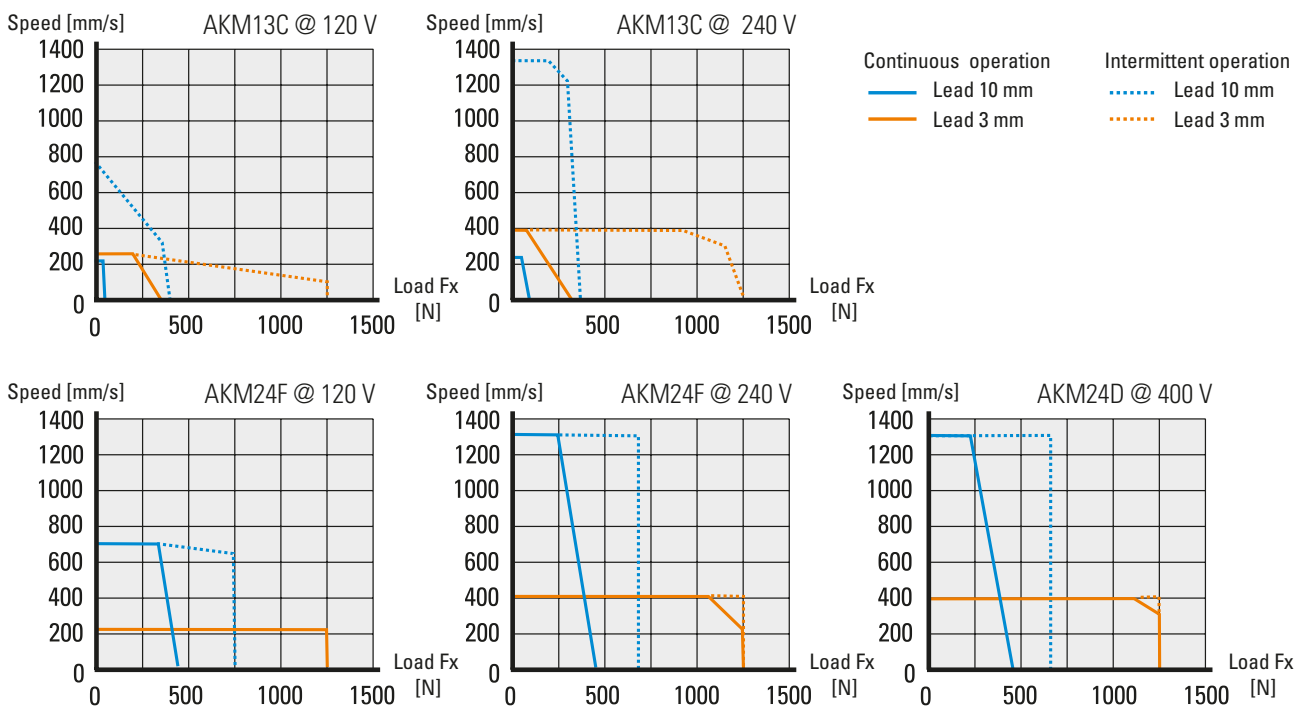

Specifications - PC32



Standard Features and Benefits

- Compact, robust and reliable
- Stroke up to 1200 mm
- Load up to 3200 N
- Speed up to 1 m/s
- Stainless steel extension tube
- IP65 as standard
- Mounting accessories according to pneumatic ISO standard

General Specifications

Parameter	PC32
Profile size (w × h) [mm]	45 × 45
Type of screw	ball screw
Protection class	IP65
Lubrication	one point lubrication of ball screw

Performance Specifications

Parameter		PC32
Stroke length (S max), maximum	[mm]	1200
Linear speed, maximum	[m/s]	1
Acceleration, maximum	[m/s ²]	10
Repeatability	[± mm]	0.01
Input speed, maximum	[rpm]	6000
Operation temperature limits	[°C]	-20 – +70
Dynamic load (F _x), maximum	[N]	3200
Dynamic load (F _y), maximum	[N]	20
Dynamic load (F _z), maximum	[N]	20
Dynamic load torque (M _z , M _y), maximum	[Nm]	25
Screw versions, diameter (d ₀) / lead (p)	[mm]	12/04, 12/10
Drive shaft force (F _{rd}), maximum	[N]	300
Input torque, maximum (RediMount models)	[Nm]	5.1
Drive shaft torque (M _{ta}), maximum	[Nm]	9.2

Definition of Forces

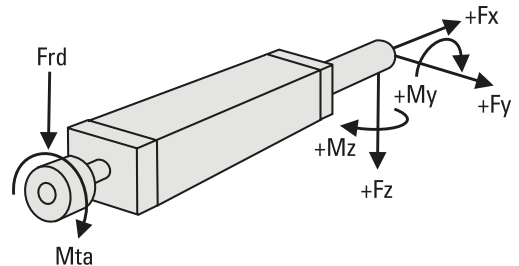

Performance Diagrams

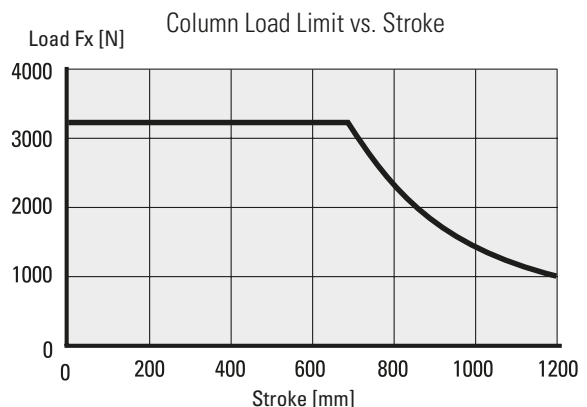
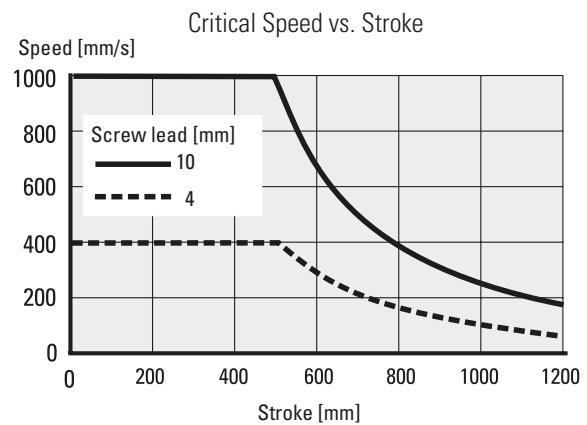
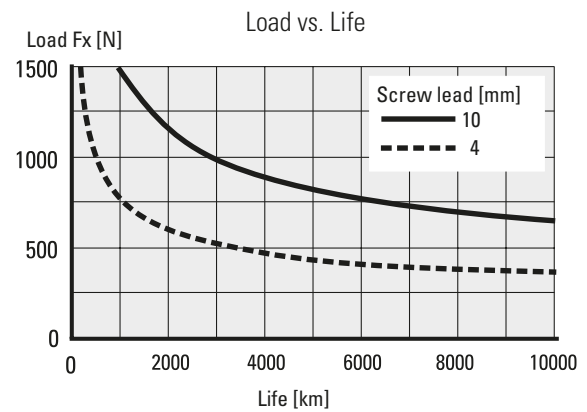

Dimensions - PC32

Dimensions for Inline Style with RediMount Motor Flange

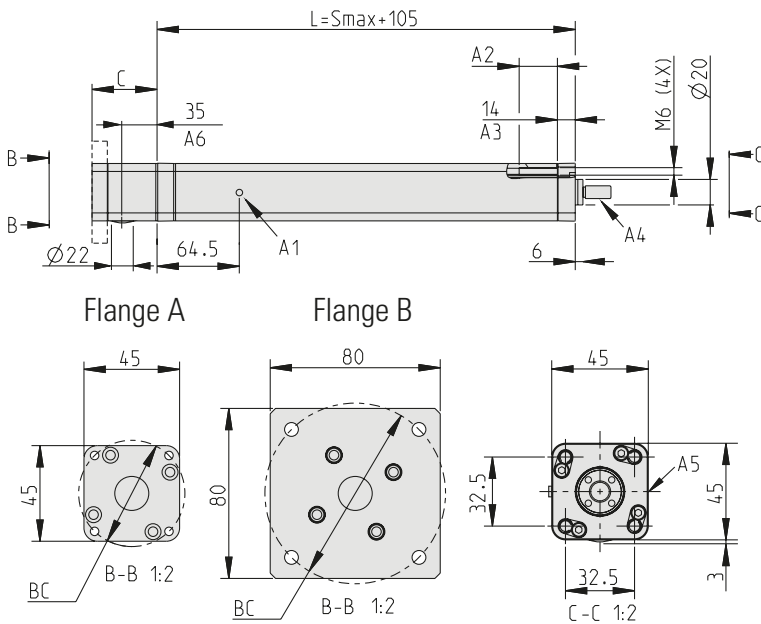

A1: grease port A2: M6 thread, max. depth 30 mm A3: no thread
 A4: male threaded rod end shown, see ordering key and accessories for information on all available ends.
 A5: side of cover tube for mounting of sensors. A6: distance to center of coupling tightening hole.

Dimensions	Projection
METRIC	

Bell House Length (C)	
Motor shaft length [mm]	C [mm]
20 - 27	59
27 - 34	66
34 - 41	73

RediMount Flange Motor Dimensions Compatibility*		
Motor data	Flange A [mm]	Flange B [mm]
Bolt circle diameter (BC)	37 - 50	50 - 99
Shaft diameter	5 - 19	
Shaft length	20 - 41	
Pilot diameter	16 - 39	16 - 75
Pilot length	max. 4	

Weight of Unit [kg]	
0.681 + (S [mm] × 0.0034)	

Dimensions for Parallel Style with RediMount Motor Flange

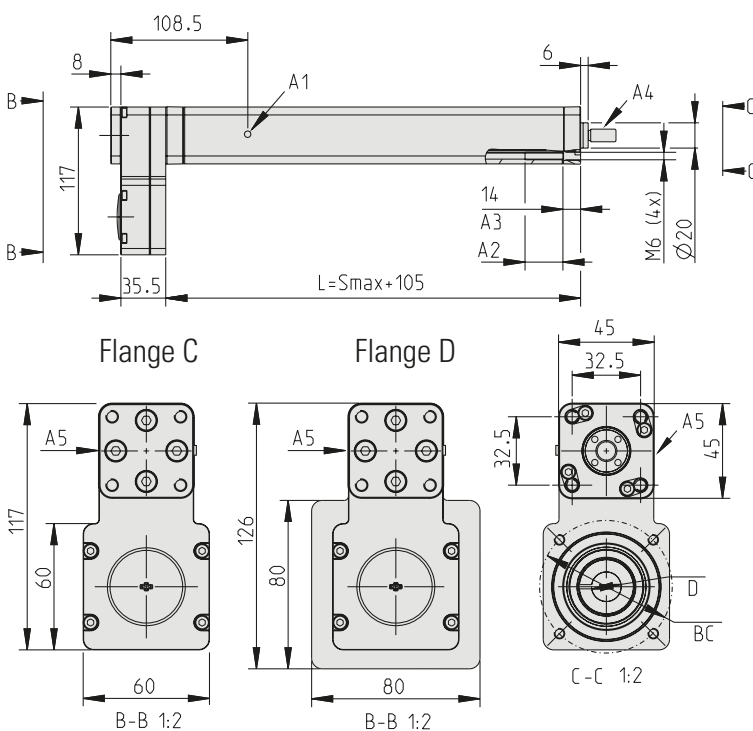

A1: grease port
 A2: M6 thread, max. depth 30 mm A3: no thread
 A4: male threaded rod end shown, see ordering key and accessories for information on all available ends.
 A5: side of cover tube for mounting of sensors.

Dimensions	Projection
METRIC	

RediMount Flange Motor Dimensions Compatibility*		
Motor data	Flange C [mm]	Flange D [mm]
Bolt circle diameter (BC)	25 - 72	72 - 99
Shaft diameter	5 - 14	
Shaft length	15 - 34	
Pilot diameter	16 - 54	16 - 74
Pilot length	max. 4	
Motor square/diameter	max. 82.5	

Weight of Unit [kg]	
1.221 + (S [mm] × 0.0034)	

* The Dimensions Compatibility tables only take motors/gears with through-hole face mount under consideration. Contact Customer Service for compatibility information for motors/gears with threaded hole face mount.

Specifications - PC32 with AKM Servo Motors

PC32 with Inline Mounted AKM Servo Motor						
Unit Type	Motor Model*	RediMount Flange Type	Bell House Length (C) [mm]	Motor Length (Lmotor) [mm]	Motor Square Size (Msq) [mm]	Total Weight of Unit with Flange and Motor [kg]
PC32LX004B	AKM24F-ANBNR-00	B	59	143.2	58	$1.66 + 0.681 + (S \text{ [mm]} \times 0.0034)$
PC32LX004B	AKM24D-ANBNR-00	B	59	143.2	58	$1.66 + 0.681 + (S \text{ [mm]} \times 0.0034)$
PC32LX001B	AKM33E-ANCNR-00	B	66	171.8	70	$2.9 + 0.681 + (S \text{ [mm]} \times 0.0034)$
PC32LX001B	AKM33H-ANCNR-00	B	66	171.8	70	$2.9 + 0.681 + (S \text{ [mm]} \times 0.0034)$

* Motors listed have no brake and are equipped with resolver. Other motor models may have different dimensions and weight.

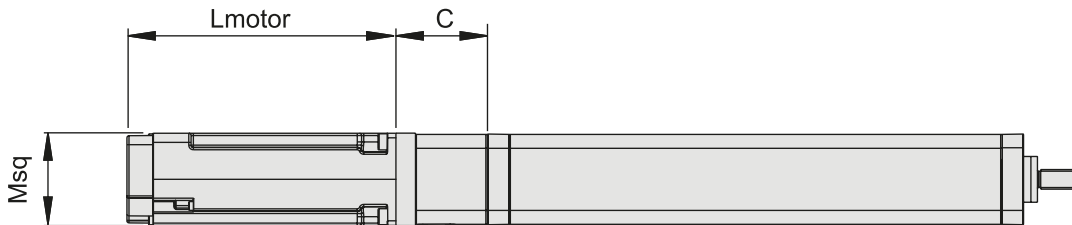

PC32 with Parallel Mounted AKM Servo Motor						
Unit Type	Motor Model*	RediMount Flange Type	Bell House Length (C) [mm]	Motor Length (Lmotor) [mm]	Motor Square Size (Msq) [mm]	Total Weight of Unit with Flange and Motor [kg]
PC32PA004B	AKM24F-ANBNR-00	C	–	143.2	58	$1.66 + 1.221 + (S \text{ [mm]} \times 0.0034)$
PC32PA004B	AKM24D-ANBNR-00	C	–	143.2	58	$1.66 + 1.221 + (S \text{ [mm]} \times 0.0034)$
PC32PA001B	AKM33E-ANCNR-00	D	–	171.8	70	$2.9 + 1.221 + (S \text{ [mm]} \times 0.0034)$
PC32PA001B	AKM33H-ANCNR-00	D	–	171.8	70	$2.9 + 1.221 + (S \text{ [mm]} \times 0.0034)$

* Motors listed have no brake and are equipped with resolver. Other motor models may have different dimensions and weight.

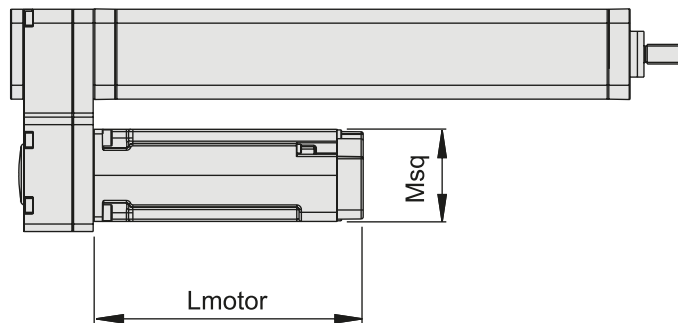

Performance Diagrams - PC32 with AKM Servo Motors

PC32 with Inline Mounted AKM Servo Motor

Continuous operation Intermittent operation
 — Lead 10 mm ····· Lead 10 mm
 — Lead 4 mm ····· Lead 4 mm

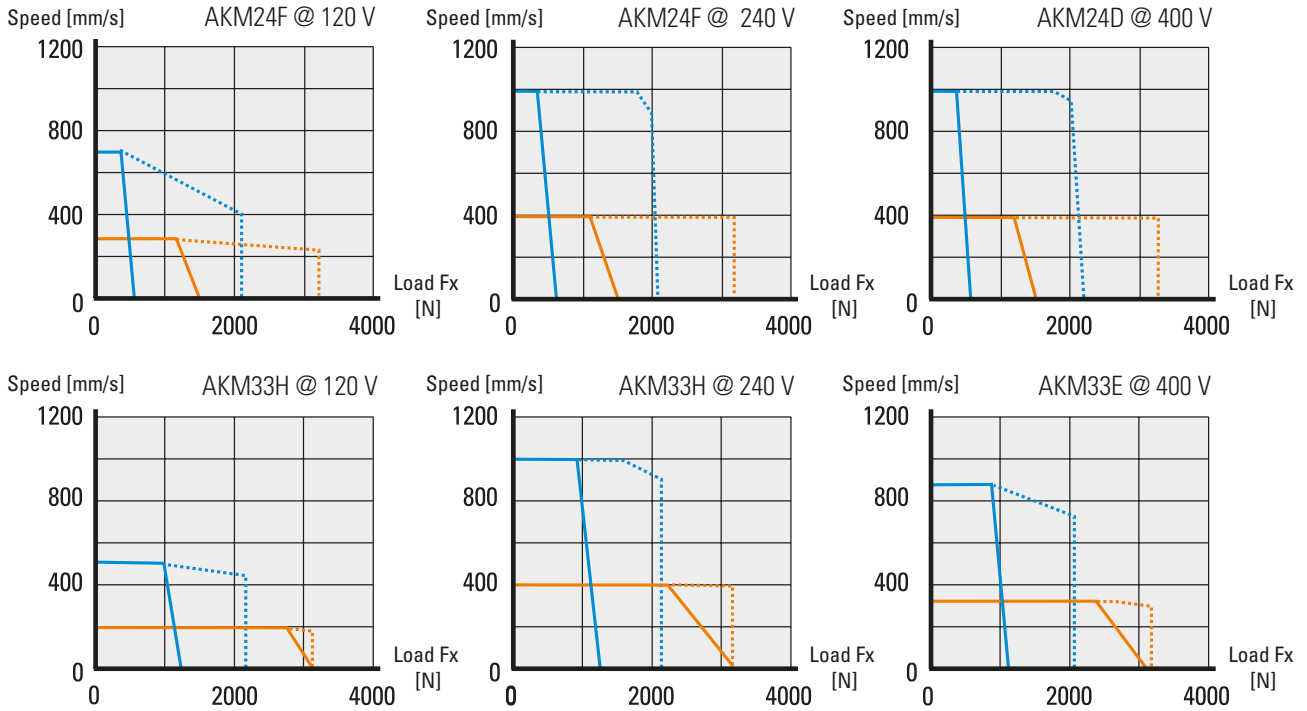

PC32 with Parallel Mounted AKM Servo Motor

Continuous operation Intermittent operation
 — Lead 10 mm ····· Lead 10 mm
 — Lead 4 mm ····· Lead 4 mm

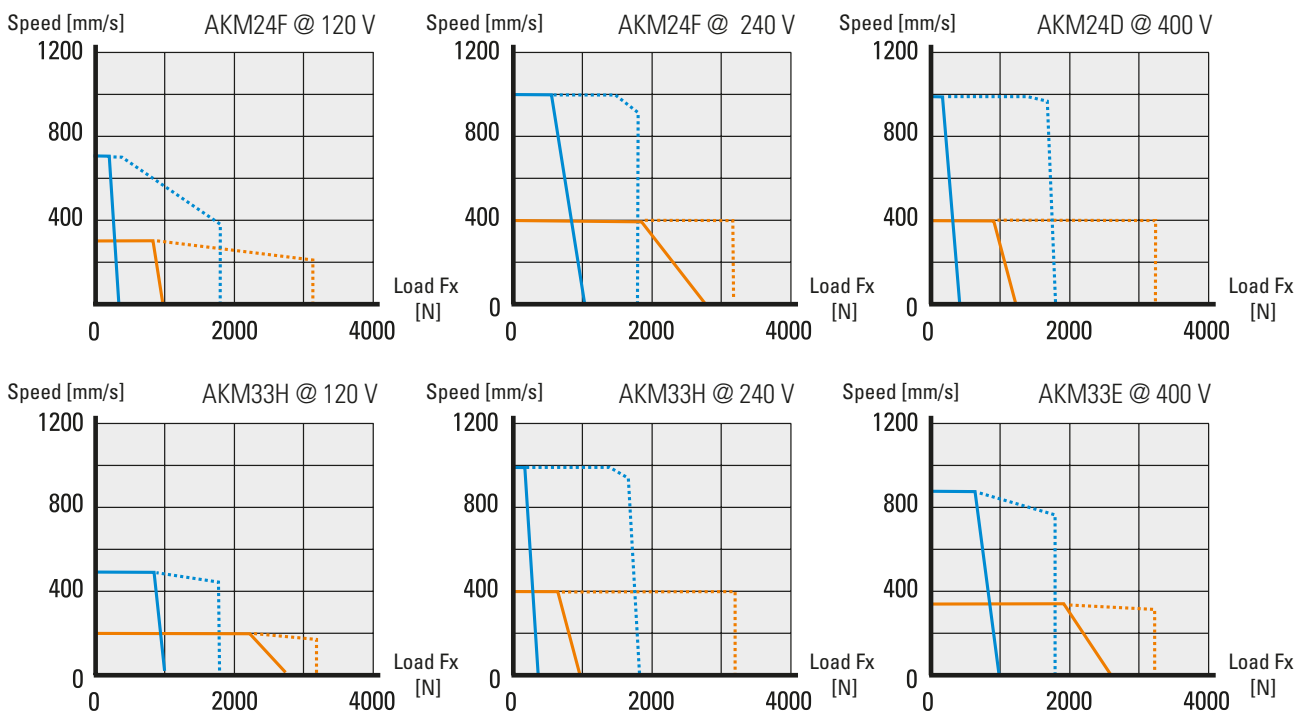

Specifications - PC40



Standard Features and Benefits

- Compact, robust and reliable
- Stroke up to 1200 mm
- Load up to 6000 N
- Speed up to 1.66 m/s
- Stainless steel extension tube
- IP65 as standard
- Mounting accessories according to pneumatic ISO standard

General Specifications

Parameter	PC40
Profile size (w × h) [mm]	55 × 55
Type of screw	ball screw
Protection class	IP65
Lubrication	one point lubrication of ball screw

Performance Specifications

Parameter		PC40
Stroke length (S max), maximum	[mm]	1200
Linear speed, maximum	[m/s]	1.66
Acceleration, maximum	[m/s ²]	10
Repeatability	[± mm]	0.01
Input speed, maximum	[rpm]	5000
Operation temperature limits	[°C]	-20 – +70
Dynamic load (F _x), maximum	[N]	6000
Dynamic load (F _y), maximum	[N]	50
Dynamic load (F _z), maximum	[N]	50
Dynamic load torque (M _z , M _y), maximum	[Nm]	25
Screw versions, diameter (d ₀) / lead (p)	[mm]	20/05, 20/10, 20/20
Drive shaft force (F _{rd}), maximum	[N]	650
Input torque, maximum (RediMount models)	[Nm]	5.8
Drive shaft torque (M _{ta}), maximum	[Nm]	24

Definition of Forces

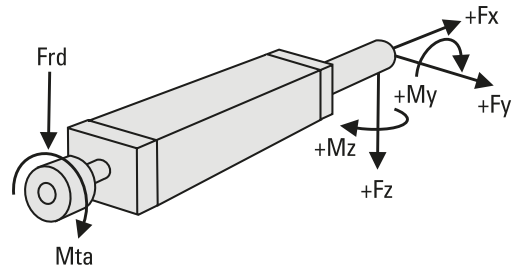

Performance Diagrams

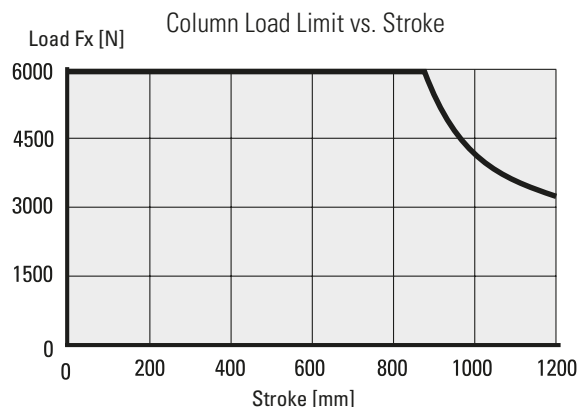
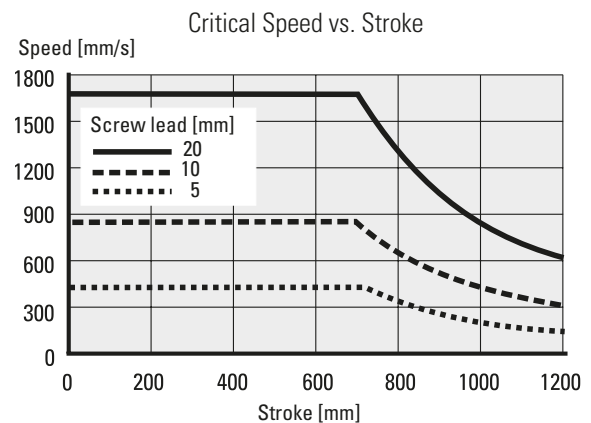
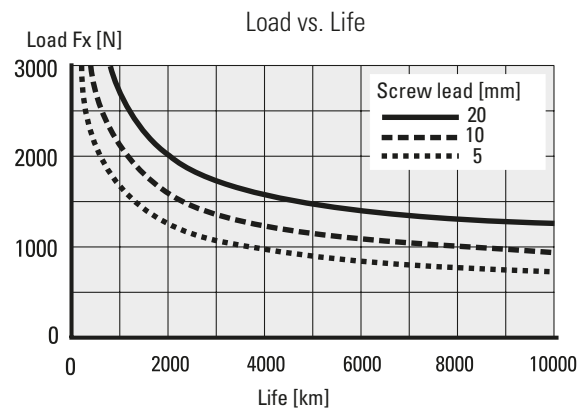

Dimensions and Performance Diagrams - PC40

Dimensions for Inline Style with RediMount Motor Flange

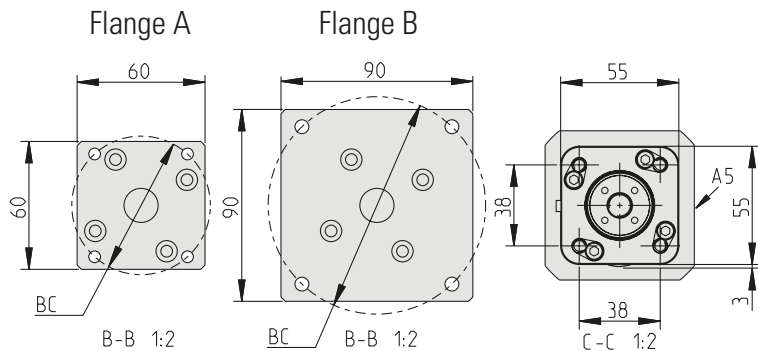
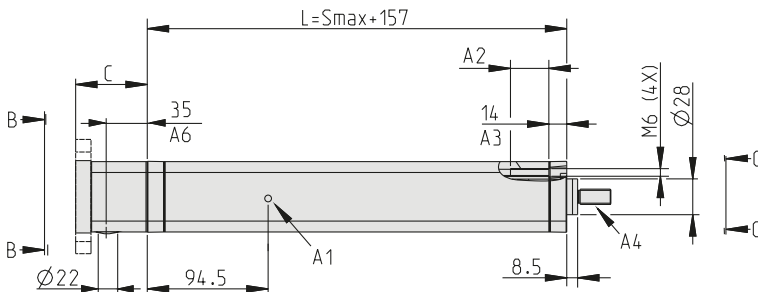

A1: grease port A2: M6 thread, max. depth 30 mm A3: no thread
 A4: male threaded rod end shown, see ordering key and accessories for information on all available ends.
 A5: side of cover tube for mounting of sensors. A6: distance to center of coupling tightening hole.

Dimensions	Projection
METRIC	

Bell House Length (C)	
Motor shaft length [mm]	C [mm]
20 - 27	62
27 - 34	69
34 - 41	76

RediMount Flange Motor Dimensions Compatibility*		
Motor data	Flange A [mm]	Flange B [mm]
Bolt circle diameter (BC)	37 - 72	72 - 107
Shaft diameter	5 - 19	
Shaft length	20 - 41	
Pilot diameter	16 - 54	16 - 85
Pilot length	max. 4	

Weight of Unit [kg]
1.853 + (S [mm] × 0.0052)

Dimensions for Parallel Style with RediMount Motor Flange

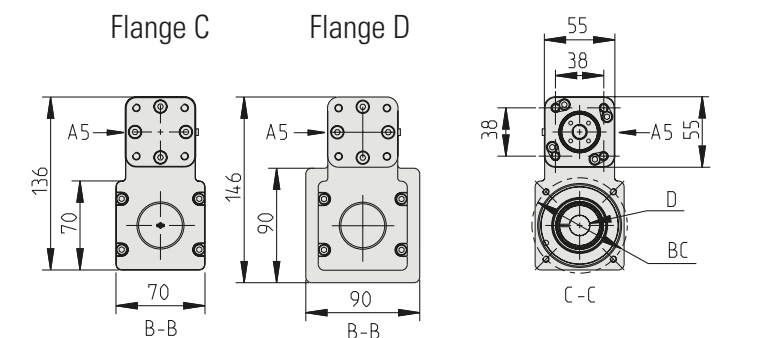
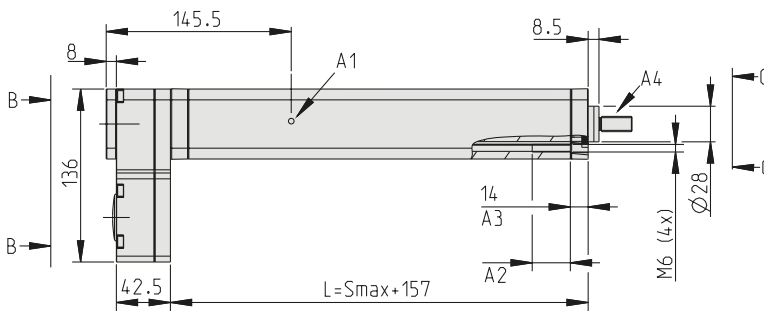

A1: grease port A2: M6 thread, max. depth 30 mm A3: no thread
 A4: male threaded rod end shown, see ordering key and accessories for information on all available ends.
 A5: side of cover tube for mounting of sensors.

Dimensions	Projection
METRIC	

RediMount Flange Motor Dimensions Compatibility*		
Motor data	Flange C [mm]	Flange D [mm]
Bolt circle diameter (BC)	26 - 85	85 - 107
Shaft diameter	5 - 16	
Shaft length	15 - 41	
Pilot diameter	16 - 64	16 - 85
Pilot length	max. 4	
Motor square/diameter	max. 90.5	

Weight of Unit [kg]
2.318 + (S [mm] × 0.0052)

* The Dimensions Compatibility tables only take motors/gears with through-hole face mount under consideration. Contact Customer Service for compatibility information for motors /gears with threaded hole face mount.

Specifications - PC40 with AKM Servo Motors

PC40 with Inline Mounted AKM Servo Motor						
Unit Type	Motor Model*	RediMount Flange Type	Bell House Length (C) [mm]	Motor Length (Lmotor) [mm]	Motor Square Size (Msq) [mm]	Total Weight of Unit with Flange and Motor [kg]
PC40LX001B	AKM33E-ANCNR-00	B	69	171.8	70	2.9 + 1.853 + (S [mm] x 0.0052)
PC40LX001B	AKM33H-ANCNR-00	B	69	171.8	70	2.9 + 1.853 + (S [mm] x 0.0052)
PC40LX023B	AKM44H-HNCNR-00	B	69	205.8	84	5.3 + 1.853 + (S [mm] x 0.0052)
PC40LX023B	AKM44K-HNCNR-00	B	69	205.8	84	5.3 + 1.853 + (S [mm] x 0.0052)

* Motors listed have no brake and are equipped with resolver. Other motor models may have different dimensions and weight.

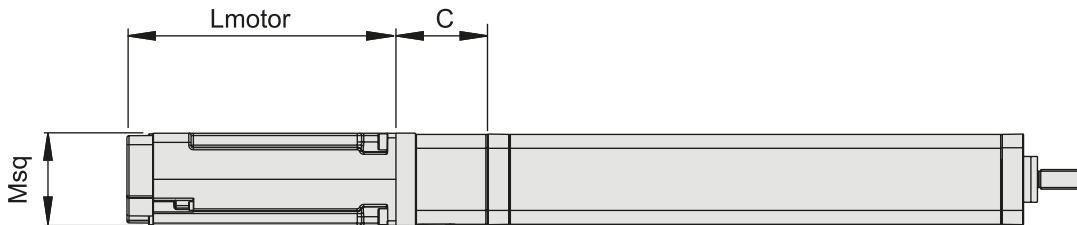

PC40 with Parallel Mounted AKM Servo Motor						
Unit Type	Motor Model*	RediMount Flange Type	Bell House Length (C) [mm]	Motor Length (Lmotor) [mm]	Motor Square Size (Msq) [mm]	Total Weight of Unit with Flange and Motor [kg]
PC40PA001B	AKM33E-ANCNR-00	C	–	171.8	70	2.9 + 2.318 + (S [mm] x 0.0052)
PC40PA001B	AKM33H-ANCNR-00	C	–	171.8	70	2.9 + 2.318 + (S [mm] x 0.0052)
PC40PA023B	AKM44H-HNCNR-00	D	–	205.8	84	5.3 + 2.318 + (S [mm] x 0.0052)
PC40PA023B	AKM44K-HNCNR-00	D	–	205.8	84	5.3 + 2.318 + (S [mm] x 0.0052)

* Motors listed have no brake and are equipped with resolver. Other motor models may have different dimensions and weight.

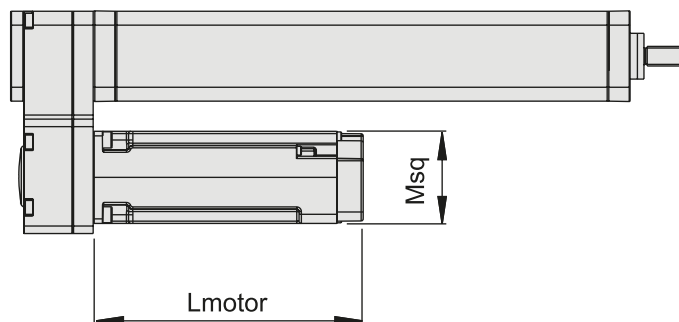

Performance Diagrams - PC40 with AKM Servo Motors

PC40 with Inline Mounted AKM Servo Motor

Continuous operation Intermittent operation
 — Lead 20 mm - - - Lead 20 mm
 — Lead 10 mm - . . . Lead 10 mm
 — Lead 5 mm Lead 5 mm

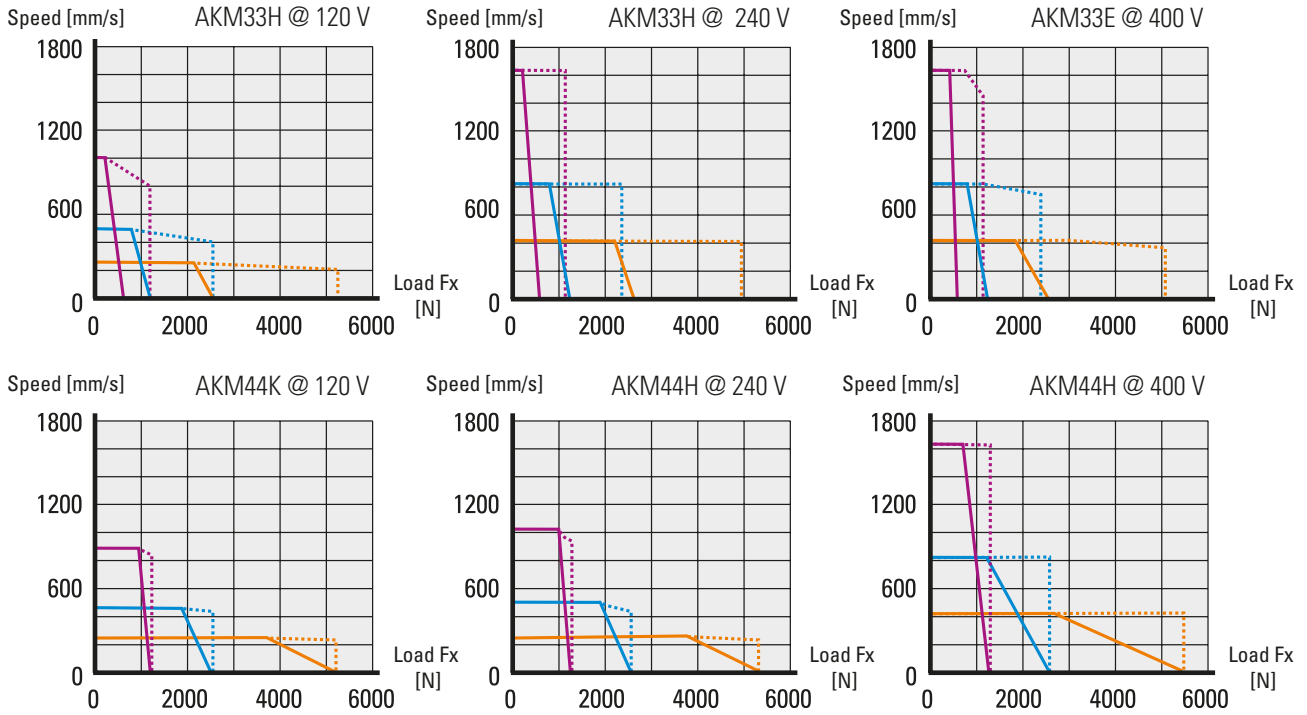

PC40 with Parallel Mounted AKM Servo Motor

Continuous operation Intermittent operation
 — Lead 20 mm - - - Lead 20 mm
 — Lead 10 mm - . . . Lead 10 mm
 — Lead 5 mm Lead 5 mm

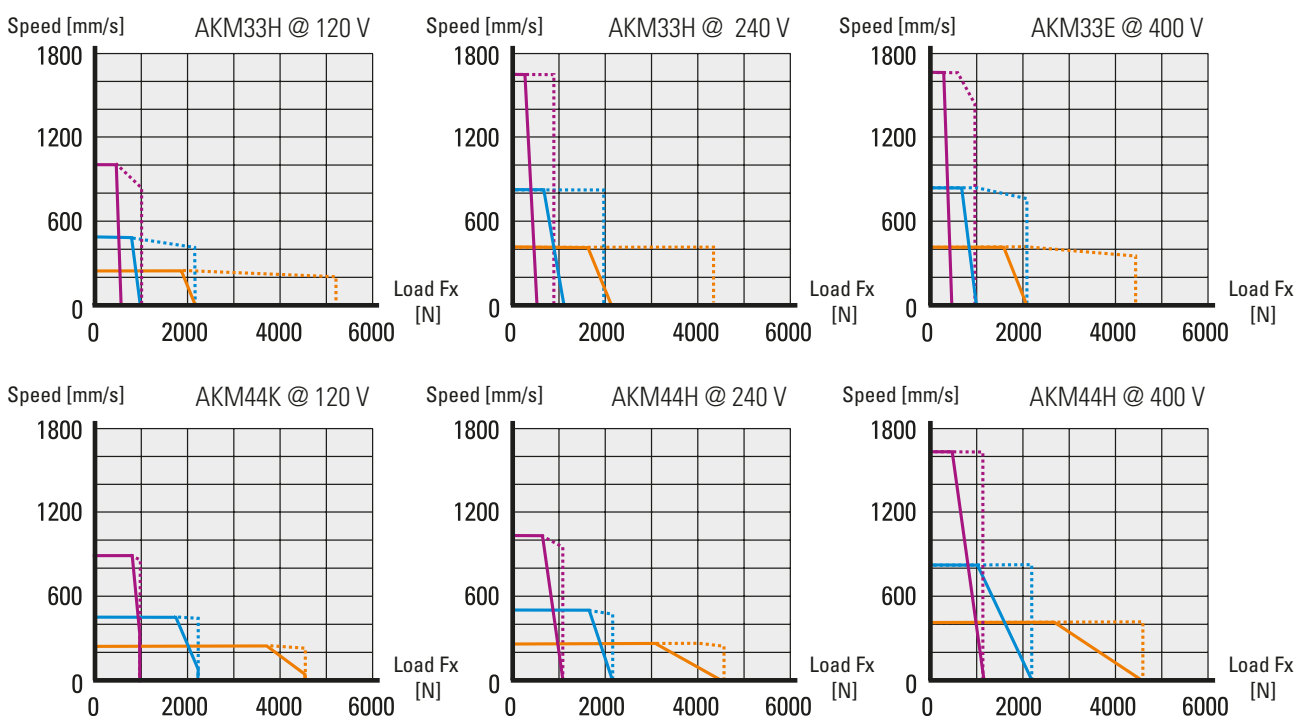

Accessories

Male Threaded Rod End

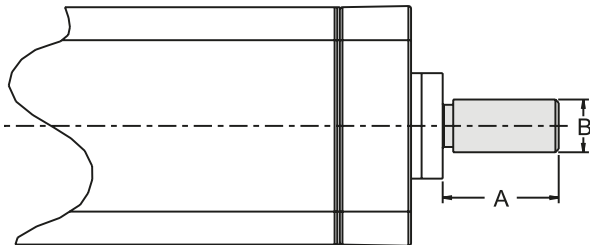

The male threaded rod end comes mounted from the factory if the ordering code states that the unit shall be equipped with one.

	A	B
PC25	22	M10 × 1.25
PC32	22	M10 × 1.25
PC40	26	M12 × 1.25

Female Threaded Rod End

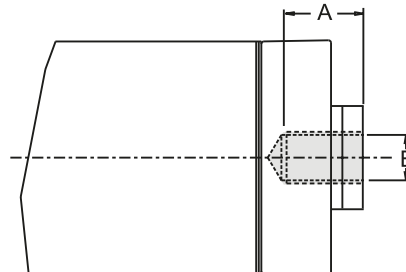

The female threaded rod end comes mounted from the factory if the ordering code states that the unit shall be equipped with one.

	A	B
PC25	15	M10 × 1.25
PC32	15	M10 × 1.25
PC40	18	M12 × 1.25

Spherical Joint

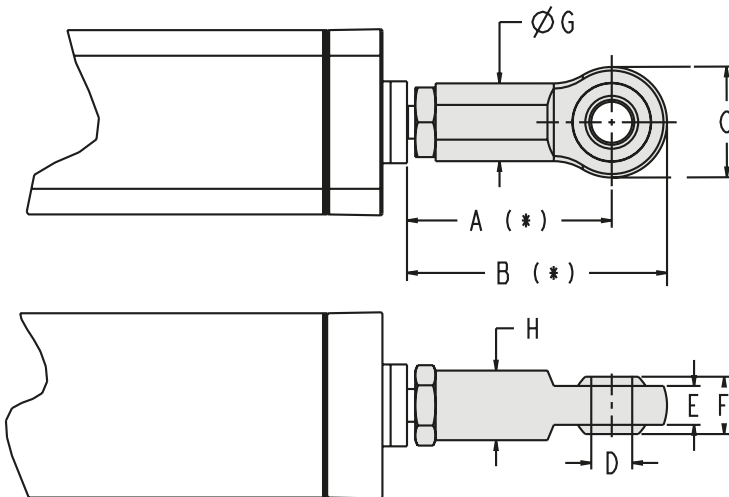

The spherical joint comes mounted from the factory if the ordering code states that the unit shall be equipped with one, but it can also be ordered as a separate part using the part number. To be able to mount a separate spherical joint, the extension tube must be equipped with a male threaded rod end.

	A (REF.) *	B (REF.) *	C	D (Ø)	E (H9)	F	G	H	p/n
PC25	50	64	28	10	10.5	14	19	17	D607 406
PC32	50	64	28	10	10.5	14	19	17	D607 407
PC40	58	74	32	12	12	16	22	19	D607 408

* assuming 2 mm gap from jam nut to shoulder.

Accessories

Front Clevis

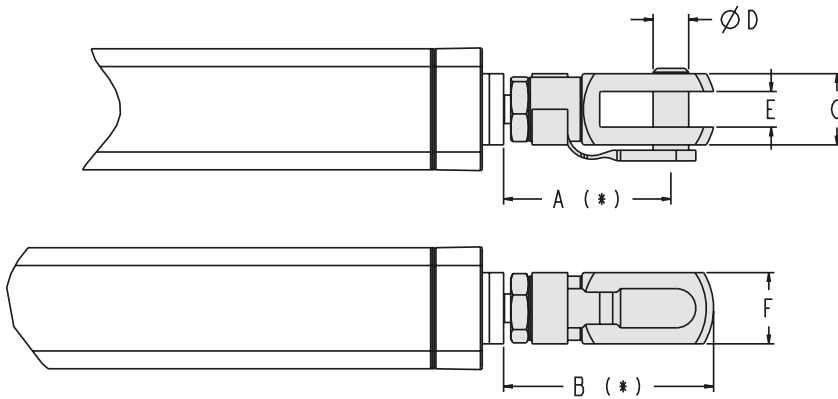

The front clevis comes mounted from the factory if the ordering code states that the unit shall be equipped with one, but it can also be ordered as a separate part using the part number. To be able to mount a separate front clevis, the extension tube must be equipped with a male threaded rod end.

	A (REF.) *	B (REF.) *	C	D (Ø h11)	E (B11)	F	p/n
PC25	47	59	20	10	10	20	D607 409
PC32	47	59	20	10	10	20	D607 410
PC40	56	70	24	12	12	24	D607 411

* assuming 2 mm gap from jam nut to shoulder.

Rear Clevis for PC25 Parallel Style Actuators

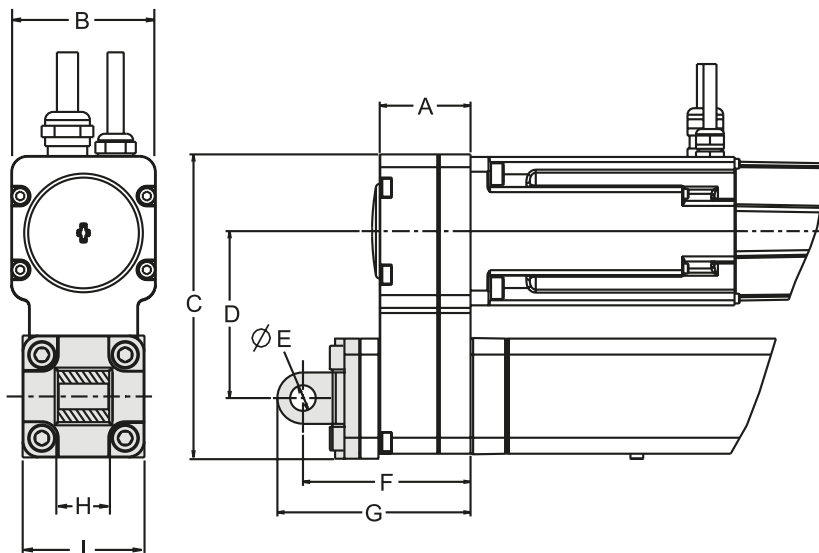

The rear clevis consists of a bracket and comes mounted from the factory if the ordering code states that the unit shall be equipped with one. It can also be ordered as a separate part (all necessary actuator attachment screws are included) using the part number.

	A	B	C	D	E (Ø H9)	F	G	H (h14)	I	p/n
PC25	36	45	92	51	8	64	72	16	38	D607 412

Accessories

Rear Clevis for PC32 and PC40 Parallel Style Actuators

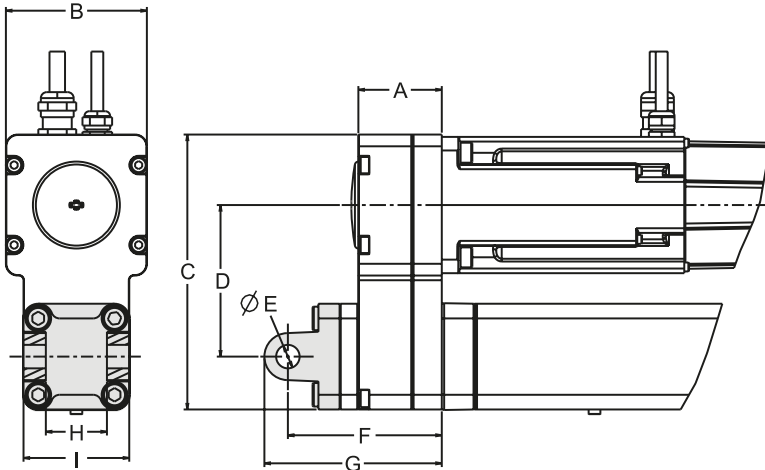

The rear clevis consists of a bracket and comes mounted from the factory if the ordering code states that the unit shall be equipped with one. It can also be ordered as a separate part using the part number, in which case it is delivered with the necessary screws to attach it to the actuator.

	A	B	C	D	E (Ø H9)	F	G	H (H14)	I	p/n
PC32	35,5	60	117	64,5	10	65,5	75,5	14	45	D607 413
PC40	42,5	70	136	73,5	12	75,5	88	16	52	D607 414

Front Mounting Plate

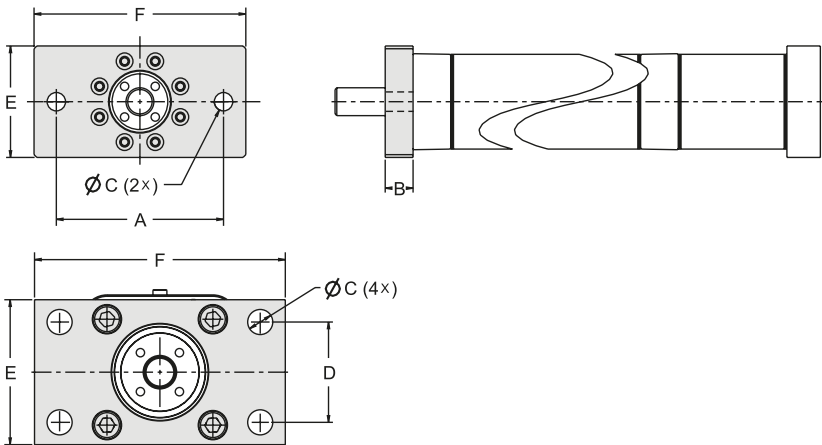

The front mounting plate consists of a plate and comes mounted from the factory if the ordering code states that the unit shall be equipped with one. It can also be ordered as a separate part using the part number, in which case it is delivered with the necessary screws to attach it to the actuator.

	A	B	C	D	E	F	p/n
PC25	60	10	6.6 (2x)	-	40	76	D607 415
PC32	64	10	7.0 (4x)	32	45	80	D607 416
PC40	72	10	9.0 (4x)	36	52	90	D607 417

Accessories

Foot Mount for Inline Style Actuators

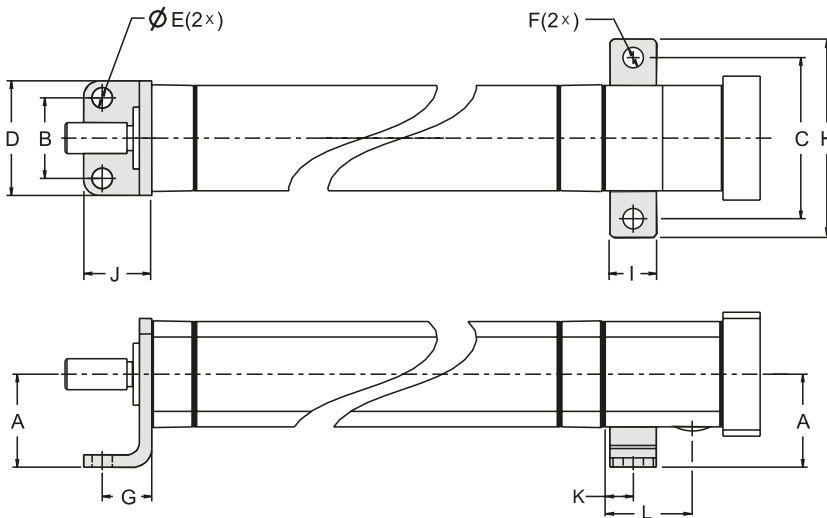

The foot mount consists of a front and rear bracket and comes mounted from the factory if the ordering code states that the unit shall be equipped with one. It can also be ordered as a separate part (all necessary actuator attachment screws are included) using the part number.

	A (JS15)	B	C	D	E	F	G	H	I	J	K	L	p/n
PC25	30	26	52	37	6.6	6.6	16	64	15	22	8.5	28	D607 418
PC32	32	32	65	45	6.6	6.6	24	78	15	35	8.5	35	D607 419
PC40	36	36	70	52	9	6.6	28	85	15	36	8.5	38.5	D607 420

Foot Mount for Parallel Style Actuators

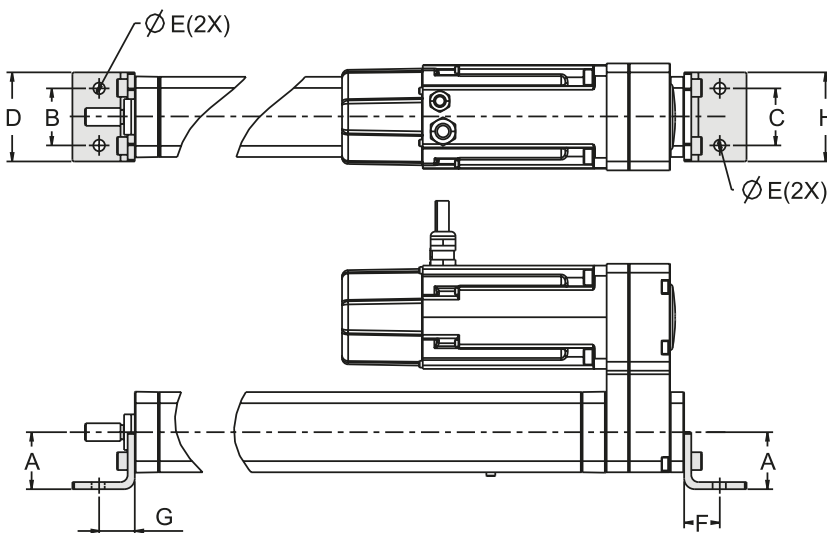

The foot mount consists of a front and rear bracket and comes mounted from the factory if the ordering code states that the unit shall be equipped with one. It can also be ordered as a separate part (all necessary actuator attachment screws are included) using the part number.

	A	B	C	D	E	F	G	H	p/n
PC25	30	26	26	37	6.6	16	16	40	D607 421
PC32	32	32	32	45	6.6	24	24	45	D607 422
PC40	36	36	52	52	9	28	28	52	D607 423

Accessories

Fixed Front Trunnion / Fixed Rear Trunnion Parallel Style Actuators

Front trunnion

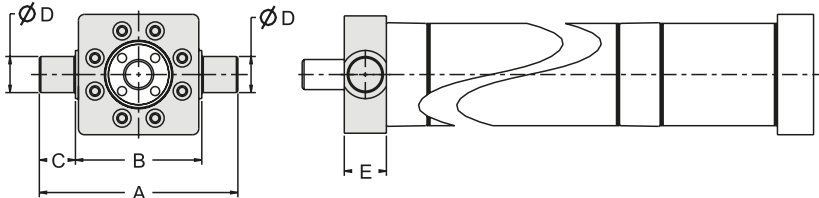

Rear trunnion

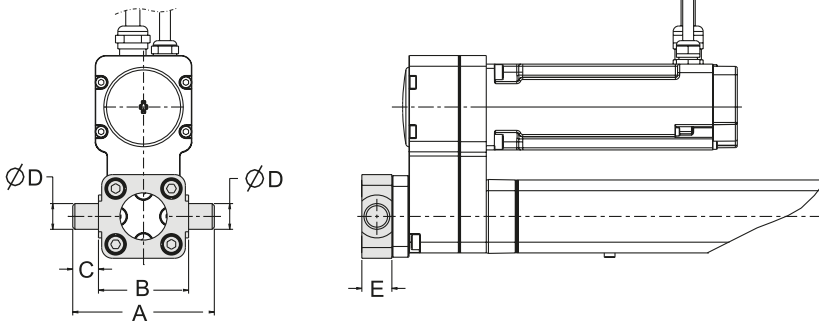

The fixed front and rear trunnions consist of a plate with two shafts and come mounted from the factory if the ordering code states that the unit shall be equipped with them. They can also be ordered as a separate part (all necessary actuator attachment screws are included) using the part numbers. The rear trunnion can only be mounted on to the belt gear on parallel style actuators.

	A (REF.)	B (h14)	C (h14)	D (e9)	E	p/n	
						Front	Rear
PC25	66	42	12	12	14	D607 424	D607 433
PC32	74	50	12	12	14	D607 425	D607 434
PC40	95	63	16	16	19	D607 426	D607 435

Movable Cover tube Trunnion

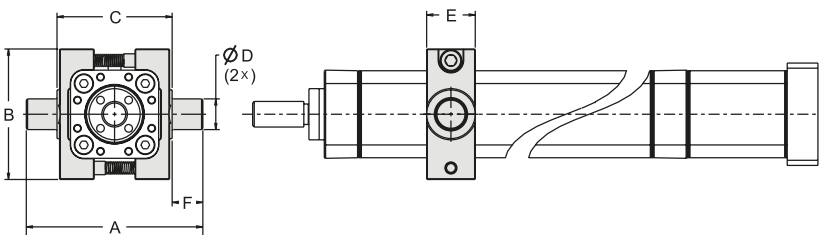

The movable trunnion consists of two clamp units that each have a shaft. The two clamp units are put around the profile of the unit at desired position and joined and locked in place by the lock screws. The movable trunnion comes mounted from the factory if the ordering code states that the unit shall be equipped with one. It can also be ordered as a separate part (all necessary actuator attachment screws are included) using the part number.

	A	B	C (h14)	D (Ø e9)	E	F (h14)	p/n
PC25	45	51	45	12	19	12	D607 427
PC32	74	65	50	12	25	12	D607 428
PC40	95	75	63	16	28	16	D607 429

Accessories

Sensor Bracket

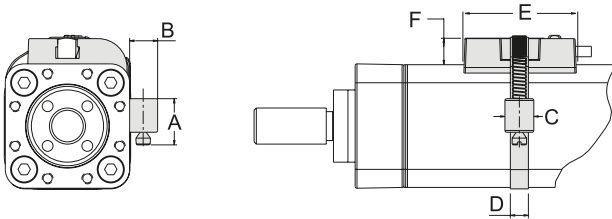

The bracket can be installed over the left or right corner of the cover tube surface under which the sensor magnet travels. The bracket comes with all necessary items to mount it to the actuator. Sensors are supplied separately, see list for available suitable sensors.

	A (REF.)	B (h14)	C (h14)	D (e9)	E	F	p/n
PC25	12.5	8	8	5	31	7.4	D607 430
PC32	12.5	8	8	5	31	7.4	D607 431
PC40	12.5	8	8	5	31	7.4	D607 432

Sensors for Sensor Bracket

Sensor

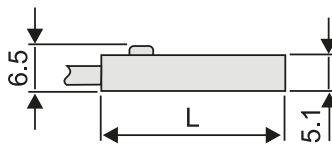

Solid state N.O.

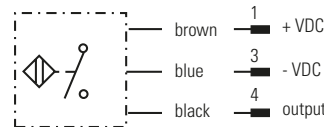

Reed switch N.O.

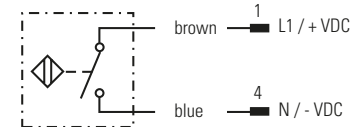

Connector

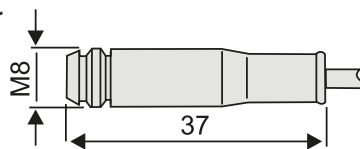

Solid state N.C.

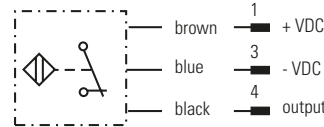

Connector

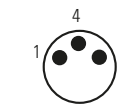

	Solid State Sensor		Solid State Sensor		Solid State Sensor		Reed Switch Sensor	
Contact type	normally open (N.O.)		normally closed (N.C.)		normally open (N.O.)		normally open (N.O.)	
Output type	PNP		PNP		NPN		potential free contact	
Voltage [VDC/AC]	10 - 30 / -		10 - 30 / -		10 - 30 / -		5 -120 / 5 -120	
Max. current [mA]	100		100		100		100	
Operating temperature [°C]	- 25 to + 85		- 25 to + 85		- 25 to + 85		- 25 to + 70	
Lead cross section [mm²]	3 × 0.14		3 × 0.14		3 × 0.14		2 × 0.14	
Length (L) [mm]	25.3		25.3		25.3		30.5	
Protection class	IP 67		IP 67		IP 67		IP 67	
Connection	flying leads	0.3 m PUR cable with connector	flying leads	0.3 m PUR cable with connector	flying leads	0.3 m PUR cable with connector	flying leads	0.3 m PUR cable with connector
p/n	D607 362	D607 363	D607 366	D607 367	D607 365	D607 364	D607 368	D607 369

Sensor Extension Cable With Connector

Type	Length	p/n
PUR cable with M8 connector and flying leads (suits all above sensors with connector)	10 m	D607 370

How To Order

The PC Series™ ordering key provides a quick overview of the product versions available. It is important to consider many details of your application when selecting a product, including the loads and speeds required as well as the product environment and necessary accessories. Use our online selection tool at www.thomsonlinear.com/pcseries or contact us for further support.

Ordering Key								
1	2	3	4	5	6	7	8	9
PC	25	LX	423	B10-	0270	M	J	1
<p>1. Actuator type PC = PC Series precision linear actuator</p> <p>2. Size 25 = profile size 34 × 34 mm 32 = profile size 45 × 45 mm 40 = profile size 55 × 55 mm</p> <p>3. Transmission type SX = inline style, directly coupled, no RediMount flange LX = inline style, directly coupled, RediMount flange PA = parallel style, 1:1 belt gear in standard position</p> <p>4. RediMount motor ID ⁽¹⁾ 000 – 998 = code for suitable flange when customers choice of motor is known 999 = code used when customers choice of motor is unknown XXX = code used when unit has no RediMount flange. ⁽²⁾</p> <p>5. Screw type and lead B03- = ball screw, 3 mm lead (possible for PC25 only) B04- = ball screw, 4 mm lead (possible for PC32 only) B05- = ball screw, 5 mm lead (possible for PC40 only) B10- = ball screw, 10 mm lead (possible for all sizes) B20- = ball screw, 20 mm lead (possible for PC40 only)</p>					<p>6. Stroke length (S max) 0000 – 9999 = distance in mm</p> <p>7. Cylinder mounting R = rear trunnion (fixed, mounted on belt gear) C = rear clevis (fixed, mounted on belt gear) F = feet kit M = trunnion (movable) T = front trunnion (fixed, mounted on front housing) P = front mounting plate X = without any cylinder mounting</p> <p>8. Rod end M = male thread (standard) F = female thread J = spherical joint C = front clevis</p> <p>9. Environmental 1 = IP65 rating (standard)</p> <p>(1) See section "RediMount™ Selection" below. (2) Always use XXX in combination with transmission type SX.</p>			

RediMount™ Selection

These are the key dimensions you need to know to be able to define the RediMount code and flange size for your choice of motor and PC Series actuator.

1. Motor shaft diameter
2. Motor shaft length
3. Mounting flange thickness
4. Motor square/diameter size
5. Mounting bolt thru hole diameter
6. Motor pilot diameter
7. Mounting bolt circle

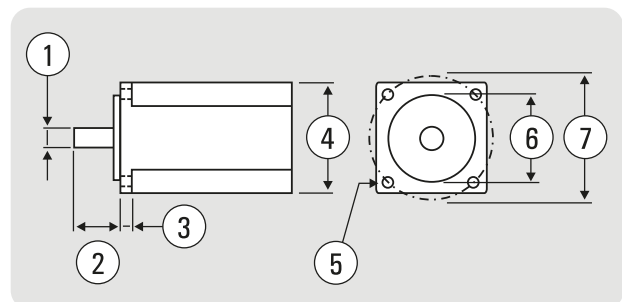

Let our online RediMount selection tool assist you!

www.thomsonlinear.com/pcseries

Online Sizing, Selection and Design Tools

There's a wide variety of application, selection and training tools available on our website to help you in the selection process. Together with our customer support center, we can help you find the PC Series actuator model that best fits your application needs. Visit www.thomsonlinear.com/pcseries for additional online information.

Product Finder

The product finder will walk you through the selection process.

www.thomsonlinear.com/pcseries



Interactive 3D CAD Models

Download interactive 3D CAD models in the most common CAD formats for free.

www.thomsonlinear.com/pcseries

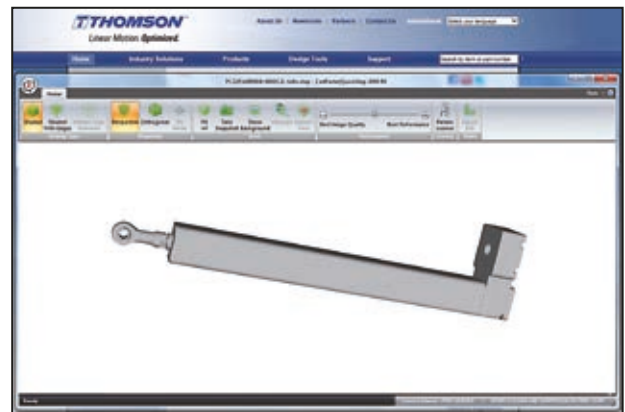

PC Series Product Website

Get additional information and learn more about the electromechanical advantage on our microsite.

www.thomsonlinear.com/conversion

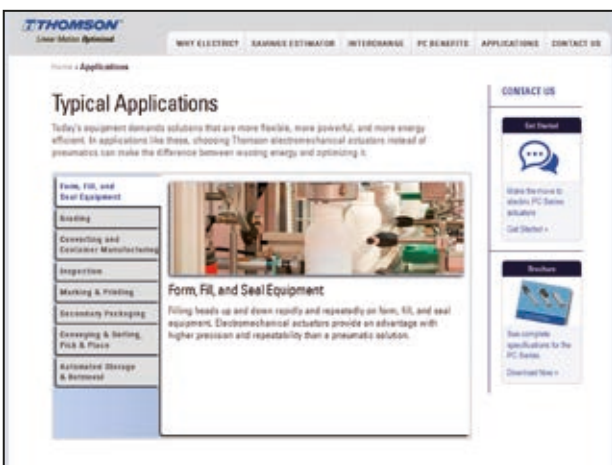

Energy Cost Estimator

See how much you could save by switching from pneumatic cylinders.

www.thomsonlinear.com/pc_calc

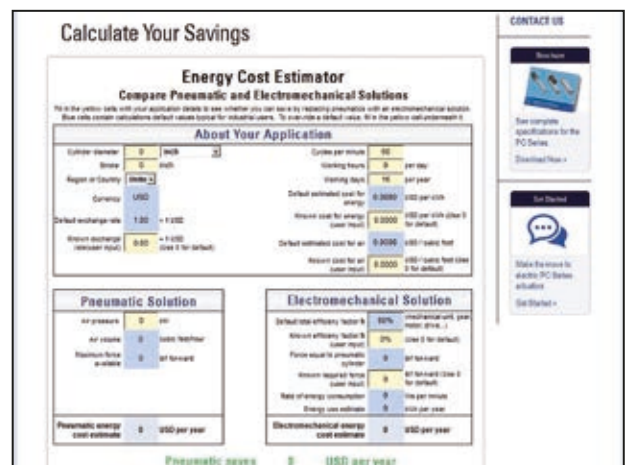

EUROPE

United Kingdom

Thomson
Office 9, The Barns
Caddsdow Business Park
Bideford, Devon, EX39 3BT
Phone: +44 (0) 1271 334 500
E-mail: sales.uk@thomsonlinear.com

Germany

Thomson
Nürtinger Straße 70
72649 Wolfschlugen
Phone: +49 (0) 7022 504 0
Fax: +49 (0) 7022 504 405
E-mail: sales.germany@thomsonlinear.com

France

Thomson
Phone: +33 (0) 243 50 03 30
Fax: +33 (0) 243 50 03 39
E-mail: sales.france@thomsonlinear.com

Italy

Thomson
Largo Brughetti
20030 Bovisio Masciago
Phone: +39 0362 594260
Fax: +39 0362 594263
E-mail: sales.italy@thomsonlinear.com

Spain

Thomson
E-mail: sales.esm@thomsonlinear.com

Sweden

Thomson
Estridsväg 10
29109 Kristianstad
Phone: +46 (0) 44 24 67 00
Fax: +46 (0) 44 24 40 85
E-mail: sales.scandinavia@thomsonlinear.com

SOUTH AMERICA

Brasil

Thomson
Av. Tamboré, 1077
Barueri, SP – 06460-000
Phone: +55 (11) 3616-0191
Fax: +55 (11) 3611-1982
E-mail: sales.brasil@thomsonlinear.com

USA, CANADA and MEXICO

Thomson
203A West Rock Road
Radford, VA 24141, USA
Phone: 1-540-633-3549
Fax: 1-540-633-0294
E-mail: thomson@thomsonlinear.com
Literature: literature.thomsonlinear.com

ASIA

Asia Pacific

Thomson
E-mail: sales.apac@thomsonlinear.com

China

Thomson
Rm 2205, Scitech Tower
22 Jianguomen Wai Street
Beijing 100004
Phone: +86 400 6661 802
Fax: +86 10 6515 0263
E-mail: sales.china@thomsonlinear.com

India

Thomson
c/o Fluke Technologies Pvt. Ltd.
#424, Deodhar Center,
Marol Maroshi Road,
Andheri – E, Mumbai – 400059 India
Phone: +91 22 29207641
E-mail: sales.india@thomsonlinear.com

Japan

Thomson
Minami-Kaneden 2-12-23, Suita
Osaka 564-0044 Japan
Phone: +81-6-6386-8001
Fax: +81-6-6386-5022
E-mail: csjapan@scgap.com

Korea

Thomson
F7 Ilsong Bldg, 157-37
Samsung-dong, Kangnam-gu,
Seoul, Korea (135-090)
Phone: +82 2 6917 5049
Fax: +82 2 528 1456
E-mail: sales.korea@thomsonlinear.com

www.thomsonlinear.com

PC_Series_Precision_Linear_Actuators_BRUK0005-06B | 20170320SK
Errors and technical alterations reserved. It is the responsibility of the product user to determine the suitability of this product for a specific application. All trademarks property of their respective owners. © 2017 Thomson Industries, Inc.

 **THOMSON**[®]

Linear Motion. Optimized.[™]