

THE COUPLING.

**R+W**<sup>®</sup>  
A POPPE + POTTHOFF COMPANY

# INDUSTRIAL COUPLINGS

# AUGEMENTED REALITY APP

## NEXT LEVEL INFORMATION DISCOVER THE FUTURE TODAY

The R+W app blurs the borders between the real and virtual worlds. Thanks to Augmented Reality technology, you can experience the R+W product portfolio like never before



Every product image in our catalog shown with this icon contains additional information. With your smartphone or tablet, you unlock all of this in virtual reality.

### JUST A FEW STEPS TO AUGMENTED REALITY

1. Download the free R+W App from the App Store or Google Play. It is available for all devices with iOS version 7.0 or higher, as well as Android devices with version 4.1 or higher.
2. Wherever you see an image with the Augmented Reality icon  in the catalog, you can use the Augmented Reality app to learn more about product.
3. The app will recognize the image and display the AR content. To enter the virtual world, simply hold your mobile device 20-30 cm above the brochure and move it slightly. 3D models, animations, videos, and other information are waiting to be discovered.



Download the R+W AR App free from the App Store or Google Play now.

The R+W App is also available as Windows version ([rw-couplings.com/app/](http://rw-couplings.com/app/)).



# NEXT LEVEL COMMUNICATION

## SOCIALIZING WITH R+W

---

Would you like to learn more about R+W and our couplings? We are pleased to take you into the world of R+W. On our YouTube channel, you can find several videos pertaining to our product line.

Are you more interested in application examples for our couplings? If so, please take a look at our case studies that can be found on our homepage. Here you can also subscribe to the R+W newsletter or find a link to download the R+W App.

And if you simply cannot get enough of us, you can find us on Facebook, Google+, and Twitter.



# WHO WE ARE.

## ABOVE ALL R+W IS: THE PERFECT COUPLING

---

When R+W Antriebselemente GmbH was first established in 1990 in Klingenberg, Germany, there were three people on board. The head office is still there, but we are now more than 220 people, with subsidiaries in the USA, China, Italy, Singapore, France and Slovakia, and are partnered with over 60 well established distributors in more than 50 countries throughout the world. Many developments have led to this success, but most importantly it was brought about by our endless search for the best possible coupling solutions as well as the high esteem in which we hold all of our customers.

### WE PROVIDE INSPIRED SOLUTIONS BACKED BY SOUND PLANNING AND DESIGN.

R+W stands for expertise in the development of solutions for precise torque transmission. The focus of our development is on innovative coupling systems for all sectors of precision drive technology. As a leading manufacturer of precision couplings and line shafts, we strive to maintain a permanent status of technology leadership in our field. Our central claim: R+W couplings ensure precision for process reliability and efficiency, and to that end we seek perfection.

Optimized for technology and business, our product portfolio includes:

- ▶ **Bellows couplings**
- ▶ **Metallic couplings**
- ▶ **Elastic couplings**
- ▶ **Ball-detent safety couplings**
- ▶ **Drive shafts**
- ▶ **Development of customized solutions with collaboration from start to finish, including:**
  - Consultation
  - Conception
  - Engineering analysis
  - Prototyping
  - Manufacturing

# TO THE TOP OF THE WORLD WITH TONS OF DRIVE

Our guiding principle, DRIVE, is a mutual calling that unifies our 220 employees: To manufacture top-notch, high-performance couplings and torque limiters for the global market; precise to the micrometer.

With DRIVE, we present ourselves as a Dynamic, Reliable, Innovative and Versatile market and technology leader that strives for Expansion by making further development and improvement part of our everyday business.

## DRIVE MEANS

### DYNAMIC

Dynamics fascinate us. For our team “dynamic” means outstanding expertise in all matters involving torque transmission and ideal collaboration for the acquisition and application of company knowledge. We work shoulder to shoulder with our customers on a dynamic course toward performance and corporate excellence!

### RELIABLE

Our course is set for the future! R+W makes state of the art, zero backlash, wear free coupling systems for the leading industries in drive technology. In addition, we manufacture pioneering special solutions produced with absolute precision. Our reliable products are a sound investment in the efficiency and dependability of your systems and machines.

### INNOVATIVE

We understand that adaptability is one of the most significant strengths of our company. A creative work environment based on the spirit of innovation does not happen by accident; instead it is the result of consistent effort.

In order to remain at the heart of technology development, we network tightly with the elite industry leaders and collaborate intensively with universities and technical colleges. This has led to the creation of a prolific research & development department in which we have been able to prototype and test our own inventions.

## VERSATILE

Versatility at R+W begins with leveraging the creativity, skills and capacities of our employees. With a broad foundation and a solution oriented mindset, we work in accordance with customer requirements and respond quickly to changes. For this very reason we are also the perfect partner for designing, engineering, and manufacturing unique and special couplings. We are particularly proud of the high level of diversification of our products and of our dedication to continuous improvement.

## EXPANDING

Expansion is a critical objective for the future of our company. Most importantly for us this means maintaining genuine industry contacts in a continuously growing global network of expertise. Our customers benefit from our broad based proximity to the market and from strong collaboration with our partners. This allows us to stay focused on our customers’ most up to date requirements, keeping us flexible and able to respond to inquiries with the right solution!

## OTHER R+W COUPLINGS

Aside from the products detailed in this catalog, we also offer high quality shaft couplings and torque limiters for servo motion control and other small to midsize precision applications.

More information on these can be found in our PRECISION COUPLINGS guide book.



# APPLICATIONS AND DESIGN FEATURES INDUSTRIAL DRIVE COUPLINGS

## SIZING AND SELECTION

---

P. 9

## INSTALLATION AND HANDLING

---

P. 31

## TORQSET® SAFETY COUPLINGS

---

ST

P. 41

from **200 – 250,000 Nm**

### AREAS OF APPLICATION

- ▶ timber processing machinery
- ▶ bulk material handling systems
- ▶ tunnel boring machinery
- ▶ industrial shredders
- ▶ rotary test stands
- ▶ extruder drives
- ▶ wastewater scraper drives
- ▶ wherever potential for torque overload exists

### FEATURES

- ▶ compact, simple design
- ▶ precise overload protection
- ▶ adjustable disengagement torque
- ▶ robust
- ▶ full disengagement up on overload

## HIGH STRENGTH DISC PACK COUPLINGS

---

LP

P. 65

from **350 – 50,000 Nm**

### AREAS OF APPLICATION

- ▶ API 610 pump packages
- ▶ paper machinery
- ▶ steel mill equipment
- ▶ test stands
- ▶ generators
- ▶ bulk material handling systems
- ▶ centrifuges
- ▶ cooling tower drives
- ▶ compressors
- ▶ printing machinery
- ▶ for infinite life in extreme conditions

### FEATURES

- ▶ maintenance free for infinite life
- ▶ frictional clamping of disc packs
- ▶ high speeds with extended DBSE
- ▶ zero backlash
- ▶ high torsional stiffness
- ▶ low restoring forces from misalignment

## FLEXIBLE GEAR COUPLINGS

---

BZ

P. 79

from **1,900 – 2,080,000 Nm**

### AREAS OF APPLICATION

- ▶ mixers
- ▶ rolling mills
- ▶ conveyors
- ▶ crushers
- ▶ shredders
- ▶ levelers
- ▶ wherever high torque and low cost meet

### FEATURES

- ▶ very compact design
- ▶ corrosion resistant
- ▶ large misalignment compensation
- ▶ reduced wear design
- ▶ low maintenance

## TORSIONALLY STIFF BELLOWS COUPLINGS

**BX**

P. 89

from **10,000 – 100,000 Nm**

### AREAS OF APPLICATION

- ▶ test stands
- ▶ centrifuges
- ▶ wind energy
- ▶ machine tools
- ▶ printing machinery
- ▶ wherever precise transmission is required

### FEATURES

- ▶ robust construction
- ▶ high torsional stiffness
- ▶ fatigue resistant for infinite life
- ▶ easy to mount and dismount
- ▶ precise rotational transmission
- ▶ minimal restoring loads under misalignment

## BACKLASH FREE SERVOMAX® ELASTIC JAW COUPLINGS

**EK**
**EZ**

P. 95

from **1,950 – 25,000 Nm**

### AREAS OF APPLICATION

- ▶ pump systems
- ▶ conveyors
- ▶ material handling systems
- ▶ extruder drives
- ▶ crushers
- ▶ shredders
- ▶ wherever shock, vibration, and misalignment need to be absorbed

### FEATURES

- ▶ vibration damping
- ▶ electrically isolating (standard version)
- ▶ misalignment compensation
- ▶ backlash free
- ▶ maintenance free

## FOR USE IN HAZARDOUS ENVIRONMENTS

**ATEX**

P. 103

### AREAS OF APPLICATION

for safer operation in industries with explosive atmospheres, such as:

- ▶ oil & gas extraction
- ▶ petrochemical processing
- ▶ munitions manufacturing
- ▶ bulk and powder processing
- ▶ paint systems

### FEATURES

For hazardous zones 1/21 and 2/22 these couplings are authorized under directive 94/9/EG.

- ▶ Safety couplings
- ▶ Bellows couplings
- ▶ Elastic jaw couplings
- ▶ Disc pack couplings

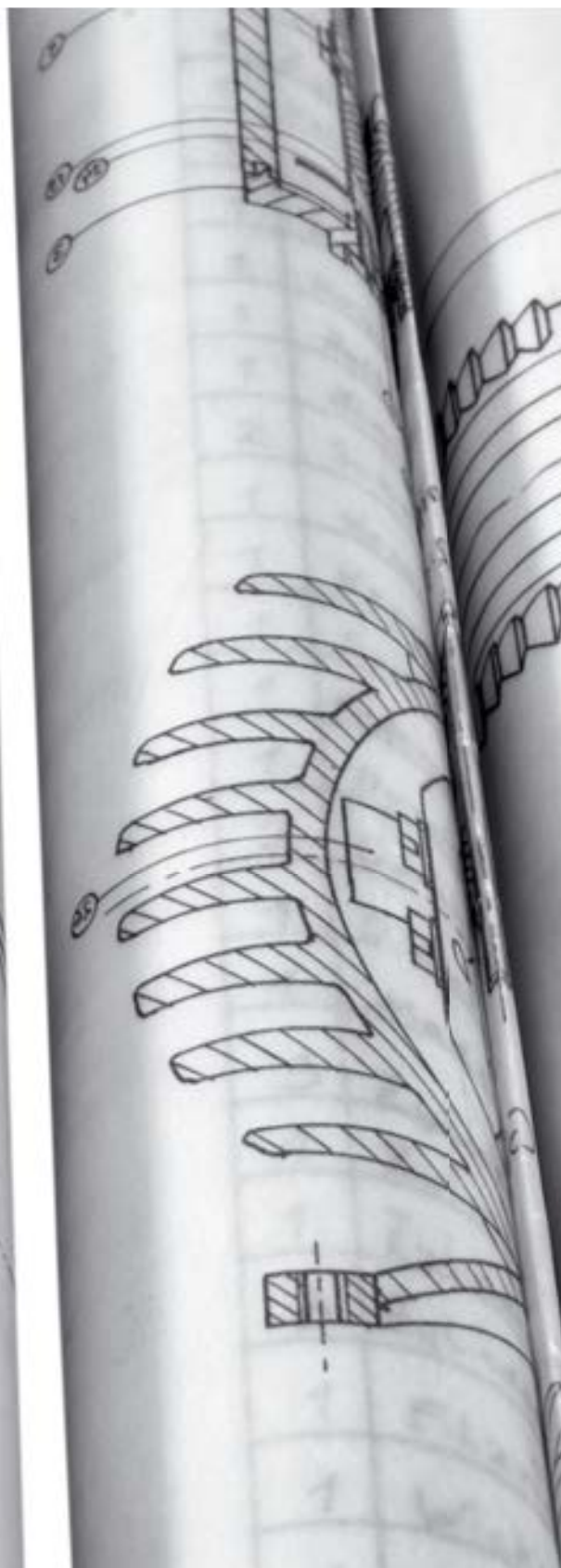
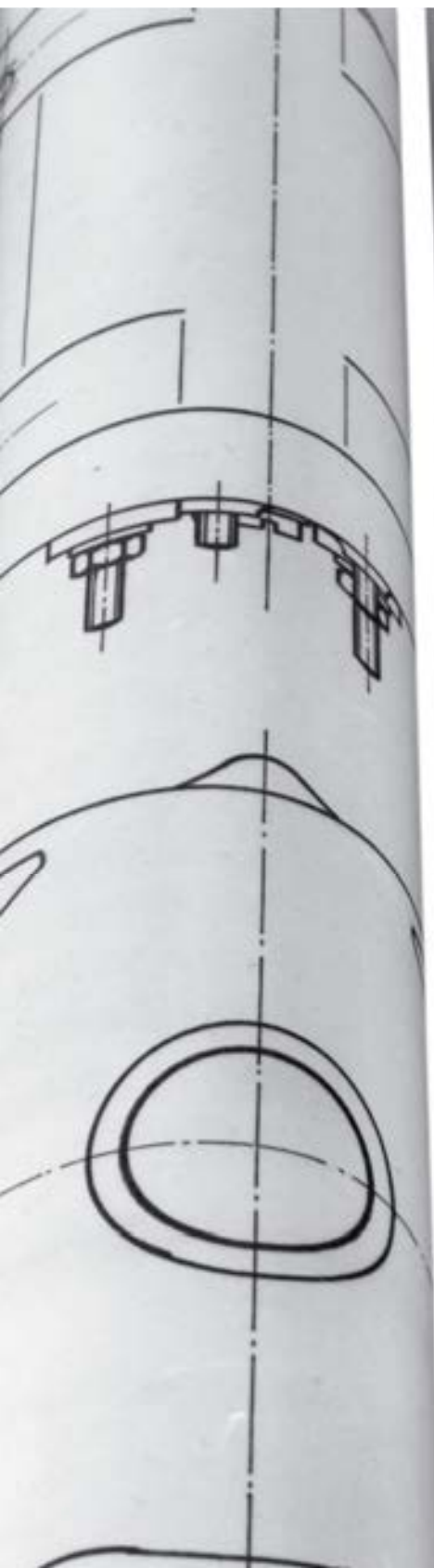



# SIZING AND SELECTION

According to  
DIN 740 part 2

# GENERAL INFORMATION

## SAFETY COUPLINGS

ST

## SAFETY COUPLINGS

### RELIABLE TORQUE OVERLOAD PROTECTION

**ST series safety couplings are designed to decouple machine drives in the event of torque overload, preventing damage and downtime.**

A series of ball bearings are spring loaded into detents on an otherwise freely spinning output plate. In the case of the ST series, these ball bearings are mounted onto plungers which are individually loaded in order to generate high clutching forces while maintaining a relatively small profile.

The transmittable torque is determined by the number and force setting of the safety elements and their distance from the center of the rotational axis. In the event of an overload, the force applied by the detents causes the plungers to overcome the spring loading and retract into the housings, resulting in a complete separation of the driving and driven hubs.

They will not re-engage automatically. After the overload condition has passed, an axial force must be applied in order to re-engage the safety elements into the detents of the output plate.



The safety elements consist of two components: the detent receptacle and the adjustable plunger mechanism.



## TORQUE ADJUSTMENT

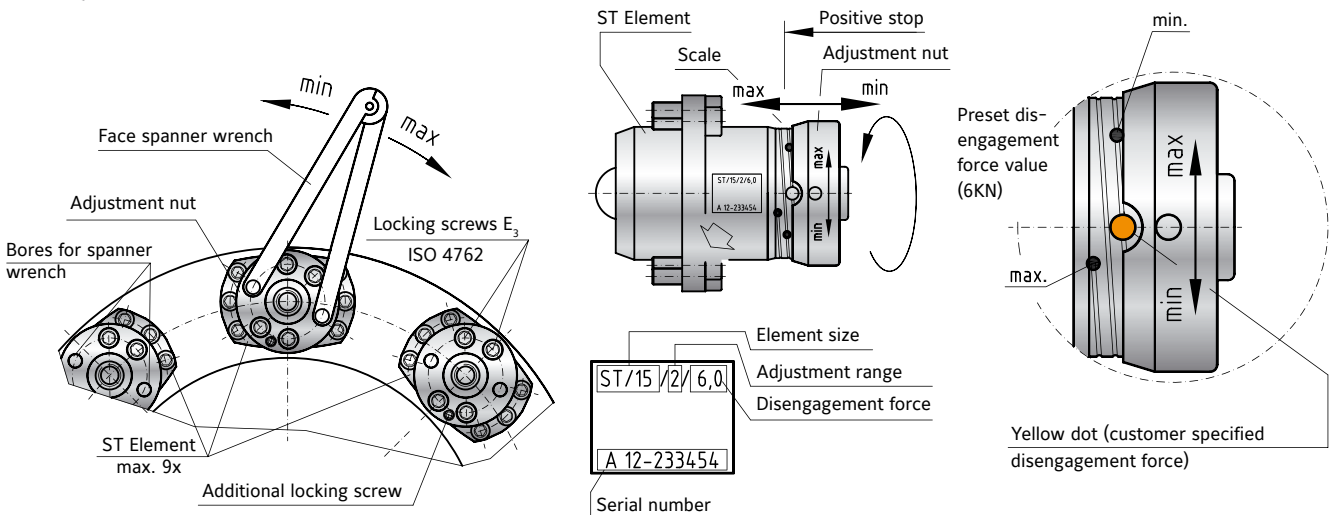

After loosening (approx. 1 rotation) the locking screws (E<sub>3</sub>), the adjustment nut can be turned to adjust the disengagement setting. Minimum, maximum and preset values are marked on the adjustment scale. After adjustment, the torque setting is secured by tightening the locking screws (E<sub>3</sub>).

► **Note**

**All safety elements must be set to the same value.**

## RE-ENGAGEMENT OF THE SAFETY ELEMENTS

After the overload has been cleared, the drive or driven side must be rotated until the re-engagement position markings are lined up. The elements can only be re-engaged in this position. The element is re-engaged through applying an axial force to the plunger. Re-engagement is audible. Once this is complete, the torque limiter is ready for operation.

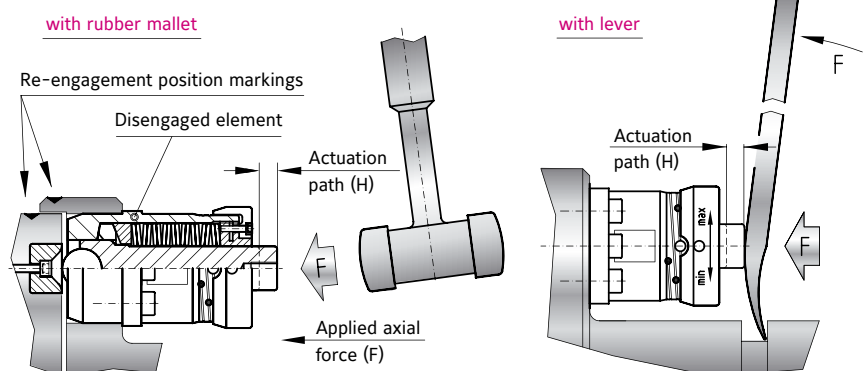

## MANUAL DISENGAGEMENT OF ELEMENTS

Prior to machine start-up, the individual elements can be manually disengaged. A manual disengagement tool is available from R+W (see page 61).

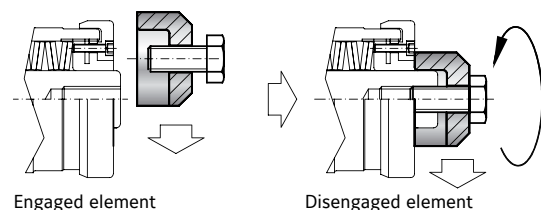

## SAFETY COUPLINGS

### SYMBOLS

$T_{AR}$	= Disengagement torque of the coupling (Nm)
$K$	= Service factor
$T_{max}$	= Maximum torque of the drive system (Nm)
$T_{AN}$	= Rated torque of the motor (Nm)
$P_{Drive}$	= Drive power (kW)
$n$	= Drive speed ( $\text{min}^{-1}$ )
$\alpha$	= Angular acceleration ( $\text{rad/s}^2$ )
$t$	= Acceleration time (s)
$\omega$	= Angular velocity ( $\text{rad/s}$ )
$J_L$	= Moment of inertia of load ( $\text{kgm}^2$ )
$J_A$	= Moment of inertia of drive ( $\text{kgm}^2$ )
$T_{AS}$	= Peak motor torque (Nm)
$S$	= Number of safety elements
$F$	= Tangential force (kN)
$r$	= Radius to element (m)
$s$	= Spindle pitch (mm)
$F_V$	= Feed force (N)
$\eta$	= Spindle efficiency
$d_0$	= Pitch diameter (mm)
$F_V$	= Feed force (N)
$C_T$	= Torsional stiffness of coupling (Nm/rad)
$J_{Masch.}$	= Total load inertia ( $\text{kgm}^2$ ) (e.g. shaft + sprocket + chain + roller + 1/2 of coupling)
$J_{Mot.}$	= Total driving inertia ( $\text{kgm}^2$ ) (e.g. motor shaft + 1/2 of coupling)
$f_e$	= Resonant frequency of the two mass system (Hz)

Shock or Load Factor $S_A$		
uniform load	non-uniform load	heavy shock load
1	2	3
For many crushing and shredding applications load factors are commonly $S_A = 2-3$		

### ACCORDING TO DISENGAGEMENT TORQUE

Safety couplings are normally selected according to the required disengagement torque, which must be greater than the maximum torque required for start-up and operation.

Disengagement torque values are often determined from the drive data and are typically a multiple of the nominal torque at the operating drive speed ( $T_{AN}$ ). In addition to a start-up torque ( $T_{max}$ ), the following values are used as further safety factors, depending on the load conditions:

- $K = 1.3$  uniform harmonious load
- $K = 1.5$  non-uniform load
- $K = 1.8$  heavy shock load

$$T_{AR} \geq K \cdot T_{max} \text{ (Nm)}$$

or

$$T_{AN} \geq 9,550 \cdot \frac{P_{Drive}}{n} \text{ (Nm)}$$

ACCORDING TO ACCELERATION  
(START-UP WITH NO LOAD)

$$T_{AR} \cong \frac{J_L}{J_A + J_L} \cdot T_{AS} \cdot S_A \cong \alpha \cdot J_L \text{ (Nm)}$$

$$\alpha = \frac{\omega}{n} = \frac{\pi \cdot n}{t \cdot 30}$$

ACCORDING TO  
ACCELERATION  
(START-UP WITH LOAD)

$$T_{AR} \cong \left[ \frac{J_L}{J_A + J_L} \cdot (T_{AS} - T_{AN}) + T_{AN} \right] \cdot S_A \cong \alpha \cdot J_L + T_{AN} \text{ (Nm)}$$

ACCORDING TO THE NUMBER  
OF SAFETY ELEMENTS

$$T_{AR} = S \cdot F \cdot r$$

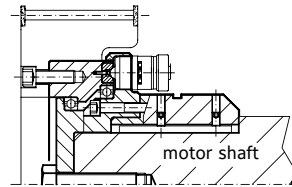
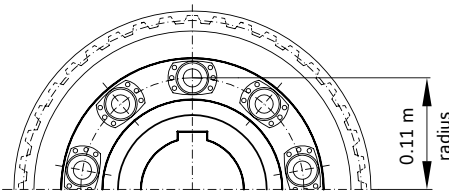

ACCORDING TO LINEAR FEED FORCE

Screw drive

$$T_{AN} = \frac{s \cdot F_v}{2,000 \cdot \pi \cdot \eta} \text{ (Nm)}$$

Rack and pinion drive

$$T_{AN} = \frac{d_0 \cdot F_v}{2,000} \text{ (Nm)}$$

ACCORDING TO RESONANT FREQUENCY

The torsional natural frequency of the coupling must be significantly higher or lower than that of the equipment. For the mechanical substitution model the two mass system applies.

$$f_e = \frac{1}{2 \cdot \pi} \sqrt{C_T \cdot \frac{J_{Masch} + J_{Mot}}{J_{Masch} \cdot J_{Mot}}} \text{ (Hz)}$$

## SAFETY COUPLINGS

### ELASTIC JAW COUPLING DESIGN ST2

Size		ST2 / 2	ST2 / 5	ST2 / 10	ST2 / 25	ST2 / 40	ST2 / 60	ST2 / 100	ST2 / 160
$T_{KN}$ Rated Torque (Nm)		2,000	3,000	5,000	7,500	20,000	20,000	40,000	40,000
$T_{Kmax}$ Maximum Torque (Nm)		4,800	7,500	18,000	25,000	48,000	48,000	120,000	120,000
Torsional Stiffness ( $10^3$ Nm/rad)		58	92	145	230	500	580	850	1000
Relative Damping		1	1	1	1	1	1	1	1

### LOAD FACTORS BY MACHINE TYPE

#### EXCAVATORS

- S bucket chain excavators
- S traveling gear (caterpillar)
- M traveling gear (rails)
- M suction pumps
- S bucket wheels
- M slewing gears

#### CONSTRUCTION MACHINERY

- M concrete mixers
- M road construction machinery

#### CHEMICAL INDUSTRY

- M mixers
- G agitators (light fluids)
- M dryer drums
- G centrifuges

#### FEEDERS AND CONVEYORS

- S belt conveyors
- G belt conveyors (bulk materials)
- M belt bucket conveyors
- M screw conveyors
- M circular conveyors
- M hoists

#### BLOWERS AND FANS<sup>1)</sup>

- G blowers (axial/radial)  $P:n \leq 0.007$
- M blowers (axial/radial)  $P:n \leq 0.07$
- S blowers (axial/radial)  $P:n > 0.07$
- G cooling tower fans  $P:n \leq 0.007$
- M cooling tower fans  $P:n \leq 0.07$
- S cooling tower fans  $P:n > 0.07$

#### GENERATORS AND TRANSFORMERS

- S generators

#### RUBBER MACHINERY

- S extruders
- S calendars
- M mixers
- S rolling millse

#### WOOD PROCESSING MACHINERY

- G woodworking machines

#### CRANES

- S traveling gears
- S hoisting gears
- M slewing gears

#### PLASTICS MACHINERY

- M mixers
- M shredders

#### METALWORKING MACHINERY

- M sheet metal bending machines
- S plate straightening machines

- S presses
- M shears
- S punch presses
- M machine tools, main drives

#### FOOD PROCESSING MACHINERY

- G filling machines
- M kneading machines
- M cane crushers
- M cane cutters
- S cane mills
- M sugar beet cutters
- M sugar beet washers

#### PAPER MACHINERY

- S wood cutters
- S calendars
- S wet presses
- S suction presses
- S suction rollers
- S drying cylinders

#### PUMPS

- S piston pumps
- G centrifugal pumps (light fluids)
- S reciprocating pumps

#### STONE AND CLAY MACHINES

- S breakers

- S rotary kilns
- S hammer mills
- S brick presses

#### TEXTILE MACHINERY

- M tanning vats
- M willows
- M looms

#### COMPRESSORS

- S reciprocating compressors
- M centrifugal compressors

#### METAL ROLLING MILLS

- M plate tilters
- S ingot handling machinery
- M winding machines (strip and wire)
- S descaling machines
- S cold rolling mills
- M chain transfers
- M cross transfers
- M roller straighteners
- S tube welding machines
- S continuous casting plants
- M roller adjustment drives

#### LAUNDRY MACHINES

- M tumblers
- M washing machines

#### WASTEWATER TREATMENT PLANTS

- M aerators
- G screw pumps

<sup>1)</sup> P = power of drive in kW  
n = speed of drive in rpm

## DESIGN FACTORS

Shock or Load Factor  $S_A$ 

Drive type	Load characteristics of driven machine		
	G	M	S
electric motors, turbines, hydraulic motors	1.25	1.6	2.0
internal combustion engines $\geq 4$ cylinder degree of uniformity $\geq 1:100$	1.5	2.0	2.5

G = smooth uniform load | M = moderate load | S = heavy shock load

Temperature Factor  $S_v$ 

Ambient Temperature	-40 C° +30 C°	+40 C°	+60 C°	+80 C°	> +80 C°
$S_v$	1.0	1.1	1.4	1.8	on request

Start Factor  $S_z$ 

Starts per Hour	30	60	120	240	>240
$S_z$	1.0	1.1	1.2	1.3	on request

## ACCORDING TO TORQUE

1. Calculate the drive torque  $T_{AN}$ .

$$T_{AN} \cong 9,550 \cdot \frac{P_{Drive}}{n} \quad (\text{Nm})$$

2. Base the coupling rated torque  $T_{KN}$  on the drive torque  $T_{AN}$  multiplied by the application factors.

$$T_{KN} \geq T_{AN} \cdot S_A \cdot S_v \cdot S_z$$

**Example:**

Coupling between an electric motor (P = 450 kW and n = 980 rpm) and a gearbox driving a belt conveyor for bulk materials.

$$T_{AN} = 9,550 \cdot \frac{450 \text{ kW}}{980 \text{ min}^{-1}} = 4,385.2 \text{ Nm}$$

smooth uniform load  
= G :  $S_A = 1.25$   
ambient temperature  
40°C :  $S_v = 1.1$   
starts  
30/h :  $S_z = 1.0$

$$T_{KN} \geq T_{AN} \cdot S_A \cdot S_v \cdot S_z$$

$$T_{KN} \geq 4,385.2 \text{ Nm} \cdot 1.25 \cdot 1.1 \cdot 1.0 = 6,029.7 \text{ Nm}$$

Selected coupling: ST2 / 10 with elastomer coupling  $T_{KN} = 6,030 \text{ Nm}$

# SIZING AND SELECTION

## SAFETY COUPLINGS

ST

### GEAR COUPLING DESIGN ST4

Size	ST4 / 2	ST4 / 5	ST4 / 10	ST4 / 25	ST4 / 40	ST4 / 60	ST4 / 100	ST4 / 160	ST4 / 250
T <sub>KN</sub> Rated Torque (Nm)	5,700	9,000	14,500	22,000	45,000	70,000	150,000	200,000	402,000
T <sub>Kmax</sub> Maximum Torque (Nm)	14,000	21,500	35,000	54,000	110,000	170,000	360,000	480,000	804,000
n Ref (max speed) (min. <sup>-1</sup> )	4,000	3,900	3,700	3,550	2,750	2,420	1,950	1,730	990



## ACCORDING TO TORQUE

1. Calculate the drive torque.  $T_{AN}$ .

$$T_{AN} \cong 9,550 \cdot \frac{P_{Drive}}{n} \quad (\text{Nm})$$

2. Base the coupling rated torque  $T_{KN}$  on the drive torque  $T_{AN}$  multiplied by the application factor. (see page 20 for shock or load factors  $S_A$ ).

$$T_{KN} \geq T_{AN} \cdot S_A$$

### Example:

Coupling between an electric motor (P = 800 kW and n = 980 rpm) and a gearbox driving a bucket chain excavator ( $S_A = 2$ ).

$$T_{AN} = 9,550 \cdot \frac{800 \text{ kW}}{980 \text{ min.}^{-1}} = 7,796 \text{ Nm}$$

$$\begin{aligned} T_{KN} &\geq T_{AN} \cdot S_A \\ T_{KN} &\geq 7,796 \text{ Nm} \cdot 2 = 15,592 \text{ Nm} \end{aligned}$$

Selected coupling: ST4 / 25 with gear coupling  $T_{KN} = 16,000 \text{ Nm}$

# SIZING AND SELECTION

LP

## DISC PACK COUPLINGS

### SYMBOLS

- $T_{KN}$  = Rated torque of the coupling (Nm)  
 $T_{AS}$  = Peak torque of the drive system  
e.g. max. acceleration torque of drive (Nm)  
or max. braking torque of load (Nm)  
 $J_L$  = Total load inertia (e.g. shaft + sprocket + chain + roller + 1/2 of coupling) (kgm<sup>2</sup>)  
 $J_A$  = Total driving inertia (motor [including gear ratio] + 1/2 of coupling) (kgm<sup>2</sup>)

Shock or Load Factor $S_A$		
uniform load	non-uniform load	highly dynamic load
1	2	3-4
Common factor for servo drives in machine tools: $S_A = 2-3$		

### ACCORDING TO TORQUE

Couplings are normally sized for the highest torque to be regularly transmitted. The peak torque of the application should not exceed the rated torque of the coupling. The following calculation provides an approximation of the minimum required coupling size, and allows for the maximum rated speed and misalignment to exist in the application.

$$T_{KN} \cong 1.5 \cdot T_{AS} \text{ (Nm)}$$

### ACCORDING TO ACCELERATION TORQUE

A more detailed calculation takes acceleration and the driving and driven moments of inertia into account. A strong inertia ratio diminishes the effect of the load factor in the sizing calculation.

$$T_{KN} \cong T_{AS} \cdot S_A \cdot \frac{J_L}{J_A + J_L} \text{ (Nm)}$$

# GENERAL INFORMATION

## GEAR COUPLING

### GEAR COUPLING

BZ

#### FUNCTION OF THE GEAR COUPLING

The high precision gearing of the coupling compensates for lateral, angular, and axial misalignment. The gearing transmits torque with minimal backlash and a high degree

of torsional rigidity. The precise geometry of the gearing ensures the performance of the coupling.

#### Axial misalignment

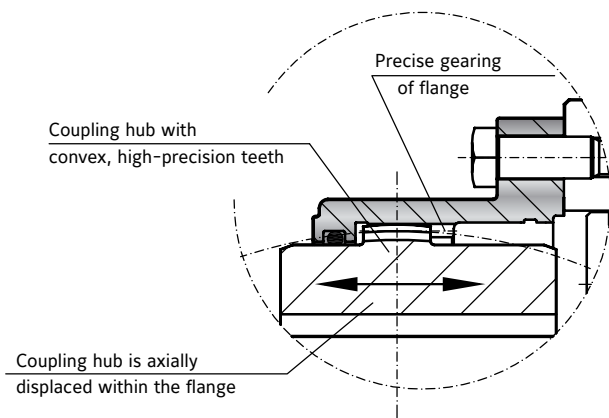

#### Angular and lateral misalignment

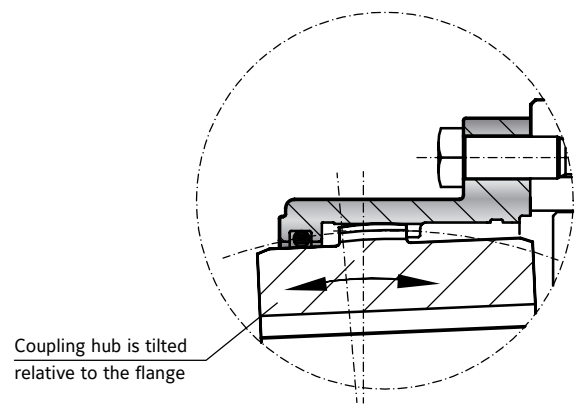

#### MAINTENANCE AND LUBRICATION

► **Note:** Lubrication of the gearing is very important to the service life of the coupling. An additional seal (optional) ensures the lubrication of the gearing over a long period of time.

#### Use only high performance grease

#### RECOMMENDED LUBRICANTS

Normal speed		High speed	
Castrol	Impervia MDX	Caltex	Coupling Grease
Esso	Fibrax 370	Klüber	Klüberplex GE 11-680
Klüber	Klüberplex GE 11-680	Mobil	Mobilgrease XTC
Mobil	Mobilux EPO	Shell	Albida GC1
Shell	Alvania grease EP R-O or ER 1	Texaco	Coupling Grease
Total	Specis EPG		

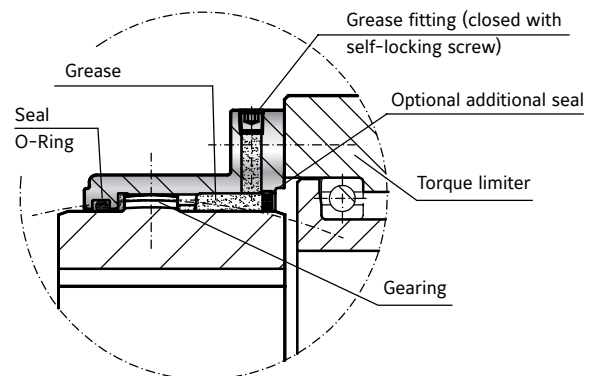

For easier handling, the coupling will be shipped unassembled.

## GEAR COUPLINGS

### SYMBOLS

- $T_{KN}$  = Rated torque of the coupling (Nm)
- $T_{AN}$  = Rated torque of the drive (Nm)
- $S_A$  = Shock or load factor
- $P$  = Drive power (kW)
- $n$  = Rotational speed (rpm)

### DESIGN FACTORS

#### Shock or Load Factor $S_A$

Drive type	Load characteristics of driven machine		
	G	M	S
electric motors, turbines, hydraulic motors	1.25	1.6	2.0
internal combustion engines $\geq 4$ cylinder degree of uniformity $\geq 1:100$	1.5	2.2	2.5

G = smooth uniform load | M = moderate load | S = heavy shock load

### LOAD FACTORS BY MACHINE TYPE

#### EXCAVATORS

- S bucket chain excavators
- S traveling gear (caterpillar)
- M traveling gear (rails)
- M suction pumps
- S bucket wheels
- M slewing gears

#### CONSTRUCTION MACHINERY

- M concrete mixers
- M road construction machinery

#### CHEMICAL INDUSTRY

- M mixers
- G agitators (light fluids)
- M dryer drums
- G centrifuges

#### FEEDERS AND CONVEYORS

- S belt conveyors
- G belt conveyors (bulk materials)
- M belt bucket conveyors
- M screw conveyors
- M circular conveyors
- M hoists

#### BLOWERS AND FANS<sup>1)</sup>

- G blowers (axial/radial)  $P:n \leq 0.007$
- M blowers (axial/radial)  $P:n \leq 0.07$
- S blowers (axial/radial)  $P:n > 0.07$
- G cooling tower fans  $P:n \leq 0.007$
- M cooling tower fans  $P:n \leq 0.07$
- S cooling tower fans  $P:n > 0.07$

#### GENERATORS AND TRANSFORMERS

- S generators

#### RUBBER MACHINERY

- S extruders
- S calendars
- M mixers
- S rolling millse

#### WOOD PROCESSING MACHINERY

- G woodworking machines

#### CRANES

- S traveling gears
- S hoisting gears
- M slewing gears

#### PLASTICS MACHINERY

- M mixers
- M shredders

#### METALWORKING MACHINERY

- M sheet metal bending machines
- S plate straightening machines

- S presses

- M shears
- S punch presses
- M machine tools, main drives

#### FOOD PROCESSING MACHINERY

- G filling machines
- M kneading machines
- M cane crushers
- M cane cutters
- S cane mills
- M sugar beet cutters
- M sugar beet washers

#### PAPER MACHINERY

- S wood cutters
- S calendars
- S wet presses
- S suction presses
- S suction rollers
- S drying cylinders

#### PUMPS

- S piston pumps
- G centrifugal pumps (light fluids)
- S reciprocating pumps

#### STONE AND CLAY MACHINES

- S breakers

- S rotary kilns
- S hammer mills
- S brick presses

#### TEXTILE MACHINERY

- M tanning vats
- M willows
- M looms

#### COMPRESSORS

- S reciprocating compressors
- M centrifugal compressors

#### METAL ROLLING MILLS

- M plate tilters
- S ingot handling machinery
- M winding machines (strip and wire)
- S descaling machines
- S cold rolling mills
- M chain transfers
- M cross transfers
- M roller straighteners
- S tube welding machines
- S continuous casting plants
- M roller adjustment drives

#### LAUNDRY MACHINES

- M tumblers
- M washing machines

#### WASTEWATER TREATMENT PLANTS

- M aerators
- G screw pumps

<sup>1)</sup> P = power of drive in kW  
n = speed of drive in rpm

## ACCORDING TO TORQUE

1. Calculate the drive torque at speed  $T_{AN}$ .

$$T_{AN} \cong 9,550 \cdot \frac{P_{Drive}}{n} \text{ (Nm)}$$

2. Determine the required torque rating of the coupling  $T_{KN}$  based on the drive torque  $T_{AN}$  multiplied by the shock or load factor  $S_A$  (see page 20)

$$T_{KN} \geq T_{AN} \cdot S_A$$

### Sample calculation:

Coupling between an electric motor (P = 800 kW at n = 980 rpm) and a transmission, driving a screw conveyor ( $S_A = 1.6$ ).

$$T_{AN} = 9,550 \cdot \frac{800 \text{ kW}}{980 \text{ min.}^{-1}} = 7,796 \text{ Nm}$$

$$\begin{aligned} T_{KN} &\geq T_{AN} \cdot S_A \\ T_{KN} &\geq 7,796 \text{ Nm} \cdot 1.6 = 12,473 \text{ Nm} \end{aligned}$$

# SIZING AND SELECTION

**BX**

## BELLOWS COUPLINGS

### SYMBOLS

- $T_{KN}$  = Rated torque of coupling (Nm)  
 $T_{AS}$  = Peak torque (Nm)  
e.g. maximum acceleration peak torque or maximum braking torque from the load  
 $J_L$  = Moment of inertia of the load (load + drive line components + half of coupling) ( $\text{kgm}^2$ )  
 $J_A$  = Drive inertia (rotor of motor + drive line components + half of coupling) ( $\text{kgm}^2$ )  
 $C_T$  = Torsional stiffness of coupling (Nm/rad)  
 $f_e$  = Resonant frequency of the two mass system (Hz)  
 $f_{er}$  = Excitation frequency of the drive (Hz)  
 $\varphi$  = Angle of twist (degree)

Shock or Load Factor $S_A$		
uniform load	non-uniform load	heavy shock load
1	2	3-4
For many crushing and shredding applications load factors are commonly $S_A = 2-3$		

## ACCORDING TO TORQUE

Couplings are normally sized for the highest torque to be regularly transmitted. The peak torque of the application should not exceed the rated torque of the coupling. The following calculation provides an approximation of the minimum required coupling size, and allows for the maximum rated speed and misalignment to exist in the application.

$$T_{KN} \cong 1.5 \cdot T_{AS} \text{ (Nm)}$$

## ACCORDING TO ACCELERATION TORQUE

A more detailed calculation takes acceleration and the driving and driven moments of inertia into account. A strong inertia ratio diminishes the effect of the load factor in the sizing calculation.

$$T_{KN} \cong T_{AS} \cdot S_A \cdot \frac{J_L}{J_A + J_L} \text{ (Nm)}$$

## ACCORDING TO RESONANT FREQUENCY

The torsional natural frequency of the coupling must be significantly higher or lower than that of the equipment. For the mechanical substitution model the two mass system applies.

In practice the following applies:  $f_e \geq 2 \cdot f_{er}$

$$f_e = \frac{1}{2 \cdot \pi} \sqrt{C_T \cdot \frac{J_A + J_L}{J_A \cdot J_L}} \text{ (Hz)}$$

Two Mass System

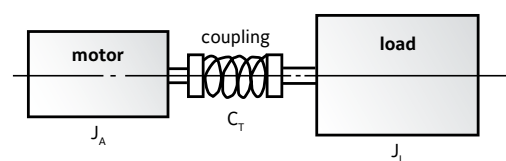

## ACCORDING TO TORSIONAL DEFLECTION

To calculate transmission error as a result of torsional stress:

$$\varphi = \frac{180}{\pi} \cdot \frac{T_{AS}}{C_T} \text{ (degree)}$$

# SIZING AND SELECTION

EK

## ELASTIC JAW COUPLINGS

### SYMBOLS

$T_{KN}$	= Rated torque of the coupling (Nm)
$T_{Kmax}$	= Maximum torque rating of coupling (Nm)
$T_S$	= Peak torque applied to the coupling (Nm)
$T_{AS}$	= Peak torque of the drive system (Nm)
$T_{AN}$	= Nominal torque of the drive system (Nm)
$T_{LN}$	= Nominal torque of the load (Nm)
$P$	= Drive power (kW)
$n$	= Rotational speed (min. <sup>-1</sup> )
$J_A$	= Total driving inertia (kgm <sup>2</sup> ) (motor [including gear ratio] + 1/2 of coupling)
$J_L$	= Total load inertia (kgm <sup>2</sup> ) (load + drive line components + half of coupling)
$J_1$	= Moment of inertia of driving coupling half (kgm <sup>2</sup> )
$J_2$	= Moment of inertia of driving coupling half (kgm <sup>2</sup> )
$m$	= Ratio of the moment of inertia of the drive to the load
$\mathcal{U}$	= Temperature at the coupling (also consider radiant heat)
$S_v$	= Temperature factor
$S_A$	= Load factor
$S_z$	= Start factor (factor for the number of starts per hour)
$Z_h$	= Number of starts per hour (1/h)

Temperature factor $S_v$	A	B	E
Temperature (v)	Sh 98 A	Sh 65 D	Sh 64 D
> -30°C to -10°C	1.5	1.3	1.2
> -10°C to +30°C	1.0	1.0	1.0
> +30°C to +40°C	1.2	1.1	1.0
> +40°C to +60°C	1.4	1.3	1.2
> +60°C to +80°C	1.7	1.5	1.3
> +80°C to +100°C	2.0	1.8	1.6
> +100°C to +120°C	-	2.4	2.0
> +120°C to +150°C	-	-	2.8

Start factor $S_z$	A	B	E
$Z_h$	up to 120	120 to 240	over 240
$S_z$	1.0	1.3	on request

Shock / load factor $S_A$	A	B	E
uniform load		non-uniform load	heavy shock load
1		1.8	2.5



## COUPLING SELECTION FOR OPERATION WITHOUT SHOCK OR REVERSAL

The rated torque of the coupling ( $T_{KN}$ ) must be greater than the rated torque of the load ( $T_{LN}$ ), taking into account the temperature at the coupling (Temperature factor  $S_v$ ). Should  $T_{LN}$  be unknown,  $T_{AN}$  can be used as a substitute in the formula.

Calculation

$$T_{KN} > T_{AN} \cdot S_v$$

Supplemental Calculation

$$T_{AN} = \frac{9,550 \cdot P}{n}$$

**Sample calculation:** (without shock loads)

**Coupling conditions**

$$v = 70^\circ \text{C}$$

$$S_v = 1.7 \text{ (for } 70^\circ \text{ / Elastomer Type A)}$$

**Drive for centrifugal pump**

$$T_{AN} = 850 \text{ Nm}$$

Calculation:  $T_{KN} > T_{AN} \cdot S_v$

$$T_{KN} > 850 \text{ Nm} \cdot 1.7$$

$$T_{KN} > \underline{1445 \text{ Nm}}$$

—————> **Result:** Coupling model EKH/2500/A ( $T_{KN} = 1950 \text{ Nm}$ ) is selected.

## COUPLING SELECTION FOR OPERATION WITH SHOCK LOADS

Same basic conditions as above. In addition, the maximum torque rating of the coupling ( $T_{Kmax}$ ) is dictated by peak torque ( $T_s$ ) due to shock loads.

Calculation

$$T_{KN} > T_{AN} \cdot S_v$$

Calculation

$$T_{Kmax} > T_s \cdot S_z \cdot S_v$$

Supplemental Calculation

$$T_{AN} = \frac{9,550 \cdot P}{n}$$

Supplemental Calculation

$$T_s = \frac{T_{AS} \cdot S_A}{m + 1}$$

$$m = \frac{J_A \cdot J_1}{J_L \cdot J_2}$$

# SIZING AND SELECTION

EZ

## ELASTOMER-DRIVE SHAFT COUPLINGS

### SYMBOLS

- A = Overall length (mm)  
AB = Distance between flextures (mm)  
 $AB = (A - 2xN)$   
Z = Tube length (mm)  
 $Z = (A - 2xH)$   
H = Length of coupling ends (mm)  
N = Length to flexure (mm)  
 $T_{AS}$  = Peak torque of the drive (Nm)  
 $\varphi$  = Torsional deflection (degree)  
 $C_T^B$  = Torsional stiffness of both flexible elements (Nm/rad)  
 $C_T^{ZWR}$  = Torsional stiffness per 1m of tubing (Nm/rad)  
 $C_T^{ZA}$  = Total torsional stiffness (Nm/rad)  
 $n_k$  = Critical speed (1/min.)  
 $C_{Tdyn}^E$  = Dynamic torsional stiffness of both elastomer inserts (Nm/rad)  
 $C_{Tdyn}^{EZ}$  = Total torsional stiffness (Nm/rad)

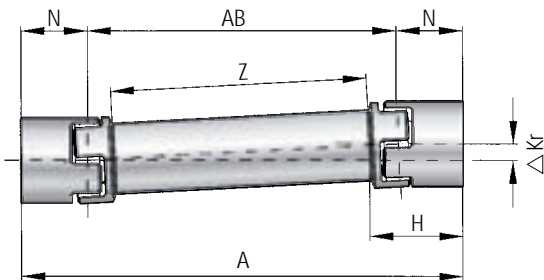

## MODEL EZ

Size	Torsional stiffness of both flexible elements		Torsional stiffness per 1m of tubing	Length of coupling ends EZ	Length to flexure	Max. axial misalignment
	Elastomer insert A $C_T^B$ (Nm/rad)	Elastomer insert B $C_T^B$ (Nm/rad)	$C_T^{ZWR}$ (Nm/rad)	H (mm)	N (mm)	$\Delta K_a$ (mm)
2500	87,500	108,000	1,000,000	142	108	5
4500	168,500	371,500	2,500,000	181	137	5
9500	590,000	670,000	5,000,000	229	171	6

Table 2

## MAXIMUM TRANSMITTABLE TORQUE BY BORE DIAMETER (Nm)

Size	Ø 35	Ø 45	Ø 50	Ø 55	Ø 60	Ø 65	Ø 70	Ø 75	Ø 80	Ø 90	Ø 120	Ø 140
2500	1900	2600	2900	3200	3500	3800	4000	4300	4600	5200		
4500		5300	5800	6300	7000	7600	8200	8800	9400	10600	14100	
9500			9200	10100	11100	11900	12800	13800	14800	16700	22000	25600

## TEMPERATURE FACTOR S

Temperature (°C)	A	B
	Sh 98 A	Sh 64 D
> -30° to -10°	1.5	1.7
> -10° to +30°	1.0	1.0
> +30° to +40°	1.2	1.1
> +40° to +60°	1.4	1.3
> +60° to +80°	1.7	1.5
> +80° to +100°	2.0	1.8
> +100° to +120°	-	2.4

## ACCORDING TO TORSIONAL STIFFNESS

**Condition:** Line shaft EZ2, Size 4500  $T_{AS} = 5,000\text{Nm}$   
**Wanted:** Total torsional stiffness  $C_T^{ZA}$

$$(C_T^{ZA}) = \frac{168,500 \text{ Nm/rad} \times (2,500,000 \text{ Nm/rad} / 1.344 \text{ m})}{168,500 \text{ Nm/rad} + (2,500,000 \text{ Nm/rad} / 1.344 \text{ m})} = 154504 \text{ [Nm/rad]}$$

$$(C_T^{ZA}) = \frac{C_T^B \cdot (C_T^{ZWR}/Z)}{C_T^B + (C_T^{ZWR}/Z)} \text{ (Nm/rad)}$$

## ACCORDING TO TORSIONAL DEFLECTION

**Condition:** Line shaft EZ2, size 4500  $T_{AS} = 5,000 \text{ Nm}$   
**Wanted:** Torsional deflection at maximum acceleration torque  $T_{AS}$

Measurement (A) of line shaft = 1.706 m  
 Length (Z) of tubing =  $A - (2 \times H) = 1.344 \text{ m}$

$$\varphi = \frac{180 \times 5,000 \text{ Nm}}{\pi \times 154504 \text{ Nm/rad}} = 1,85^\circ$$

With a maximum torque of 5,000 Nm the torsional deflection is 1.85°

$$\varphi = \frac{180 \cdot T_{AS}}{\pi \cdot C_T^{ZA}} \text{ (degree)}$$

## DRIVE SHAFT COUPLINGS

### ACCORDING TO MAXIMUM MISALIGNMENT

Lateral misalignment  $\Delta Kr$



$$\Delta Kr_{\max} = \tan \Delta \frac{Kw}{2} \cdot AB$$

$$AB = A - 2N$$

Angular misalignment  $\Delta Kw$



$$\Delta Kw_{\max} = 2^\circ$$

Axial misalignment  $\Delta Ka$



$\Delta Ka$  See table  
(Page 27)

### R+W CALCULATION PROGRAM

Using proprietary software, R+W will calculate the specific mechanical details of exactly the model you plan to use. Overall length, tube materials (e.g. steel, aluminum, CFK), and other factors are used to determine a number of performance values unique to your line shaft coupling.

Critical speed	$n_k = 1/\text{min.}$
Torsional stiffness of tubing	$C_T^{ZWR} = \text{Nm/rad}$
Overall stiffness	$C_T^{ZA} = \text{Nm/rad}$
Torsional deflection	$\varphi = \text{degree-min-sec}$
Total Weight	$m = \text{kg}$
Moment of inertia	$J = \text{kgm}^2$
Maximum misalignment	$\Delta Kr = \text{mm}$

# GENERAL INFORMATION

## ELASTOMER SEGMENT ST2

ST2

### ELASTIC SAFETY COUPLING

#### THE ELASTOMER SEGMENT

The compensating elements of the ST2 safety couplings are the elastomer segments. They transmit torque while damping vibration and compensating for lateral, axial

and angular misalignment. Three different versions are available with version A being supplied unless otherwise specified.

Type	Relative damping ( $\psi$ )	Temperature range constant	Temperature range peak	Material	Shore hardness	Features
A (Standard)	1.0	-40°C to +80°C	+90°C	Natural and synthetic rubber	75-80 Shore A	Very high wear resistance
B	1.0	-40°C to +100°C	+120°C	Synthetic rubber	73-78 Shore A	Resistant to many oils and fuels
C	1.0	-70°C to +120°C	+140°C	Silicone rubber	70-75 Shore A	High temperature range

#### ► Note

Elastomer segments can be easily changed after installation. Every coupling utilizes 6x elastomer segments. The elastomer segments do not need to be installed prior to coupling mounting.

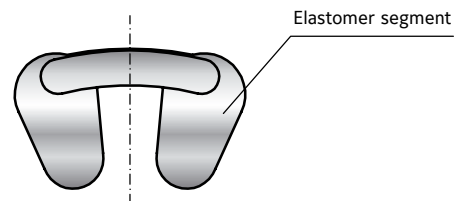

#### CHANGING THE ELASTOMER SEGMENTS

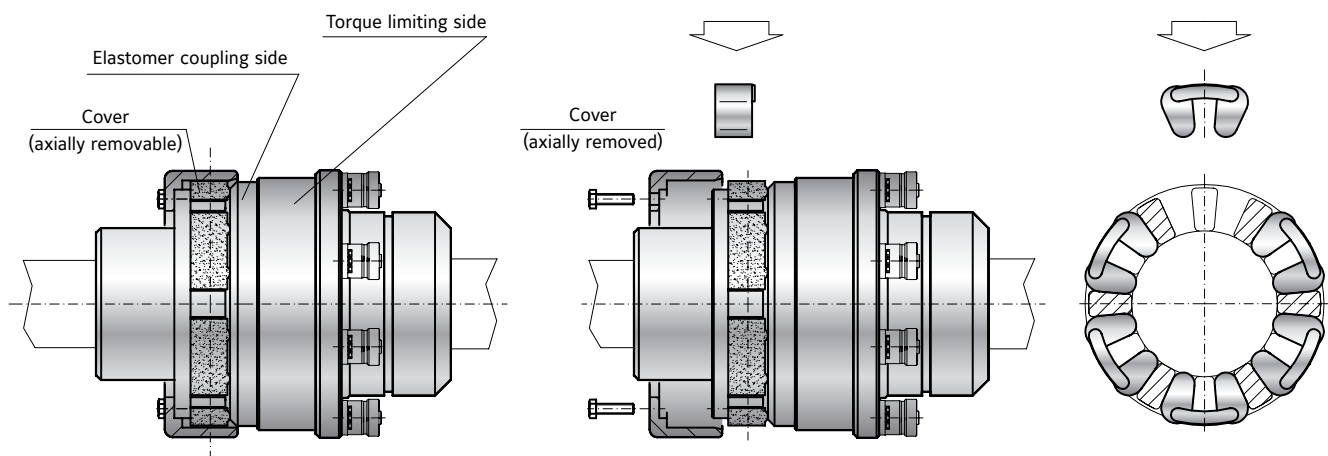

For easier handling, the coupling will be shipped unassembled.



# INSTALLATION

## SHAFT / AXIS MISALIGNMENT

Exact alignment of the shaft axes extends the service life of the coupling and adjacent components by minimizing reaction loads from misalignment.

# INSTALLATION AND HANDLING INDUSTRIAL DRIVE COUPLINGS

## INDIRECT DRIVES

### SAFETY COUPLINGS

Drive attachments such as sprockets and universal joint shafts need to be centered on one of the precision locating features in the output flange of the coupling. In the case of sprockets, gears, sheaves, etc, the radial load should be centered between the two rows of ball bearings, integral to the coupling. In case this is not possible the overhung load can be supported by additional outboard bearings on the shaft. Make sure to observe the allowable size and radial load ratings for the safety couplings.

**ST1**

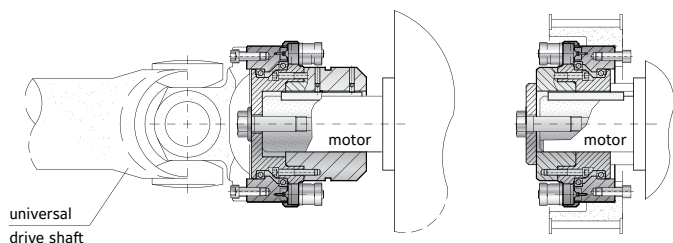

WITH KEYWAY MOUNTING

**STR**

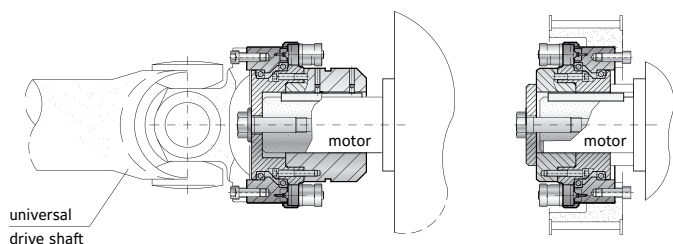

SPECIAL ROBUST VERSION

**STN**

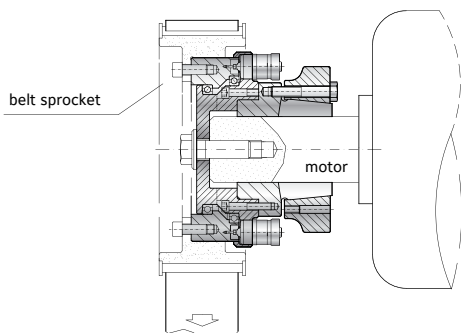

WITH CONICAL CLAMPING RINGS

**STF**

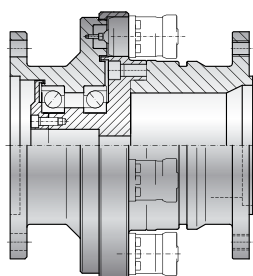

WITH FLANGE MOUNTING



# DIRECT DRIVES

## SAFETY COUPLINGS

Model ST safety couplings are designed for high torque. This is accomplished by means of the robust spring plunger safety elements, which are uniformly distributed around the face of the coupling body. These safety elements provide a spring loaded form fit connection between the input and output of the coupling system. Transmittable torque is determined by the quantity and force settings of the safety elements. At a predetermined maximum torque level, the balls of the safety elements exit the conical detents in the output flange of the coupling, and retract inside the housings of the safety elements. This creates a complete disconnection of the input and output of the coupling system. Re-engagement is performed by applying pressure to the back side of the safety elements, causing the balls to be released back into their detents. The coupling system is sealed to prevent dirt and debris from entering, and to prevent grease from escaping.

STE

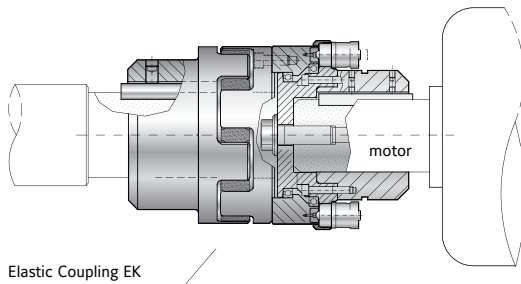

WITH KEYWAY MOUNTING  
AND ELASTIC COUPLING

ST2

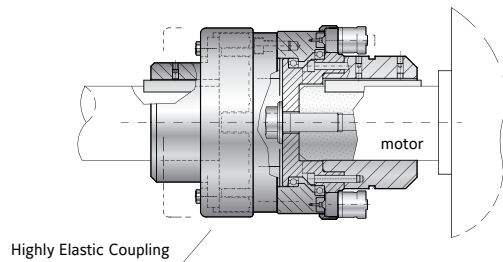

WITH KEYWAY MOUNTING AND  
HIGHLY ELASTIC COUPLING

ST4

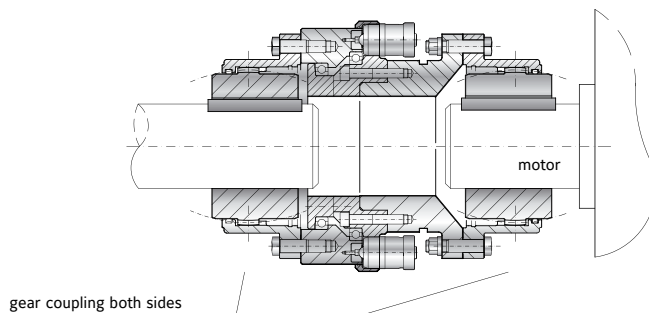

WITH KEYWAY MOUNTING  
AND GEAR COUPLING

# INSTALLATION AND HANDLING INDUSTRIAL DRIVE COUPLINGS

## DIRECT DRIVES

### DISC PACK COUPLINGS

R+W LP series couplings come with the disc packs fully assembled. They need only to be mounted to the hubs and spacers during installation. Once assembled the disc pack couplings compensate for axial, lateral, and angular shaft misalignment. Torque is transmitted across the disc packs purely by the frictional flanged connection created by the grade 12.9 bolts. This helps to avoid problems associated with backlash, stress concentration, and micro movements, while also making the coupling assembly more torsionally stiff.

LP1

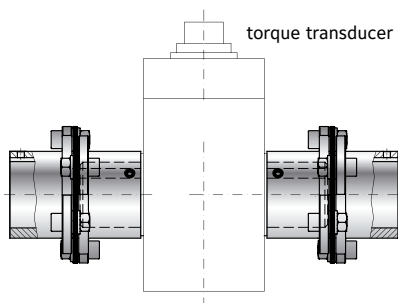

WITH KEYWAY MOUNTING AND  
SINGLE FLEX FOR INTERMEDIATE  
LOAD SUPPORT

LP2

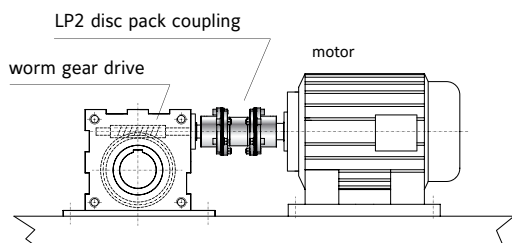

WITH KEYWAY MOUNTING AND  
DOUBLE FLEX

LPA

LPAI

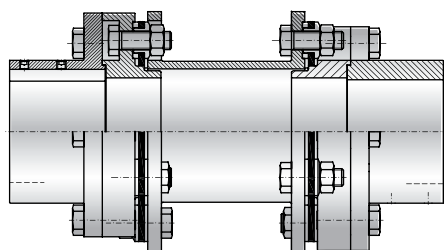

WITH KEYWAY MOUNTING  
FOR API 610 / 671  
METRIC OR IMPERIAL

# DIRECT DRIVES

LP3

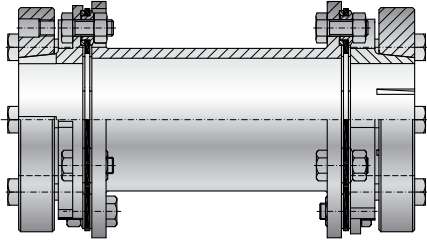

WITH CONICAL CLAMPING RING  
AND DOUBLE FLEX

LP4

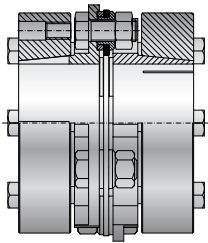

WITH CONICAL CLAMPING  
RING AND SINGLE FLEX FOR  
INTERMEDIATE LOAD SUPPORT

LPZ

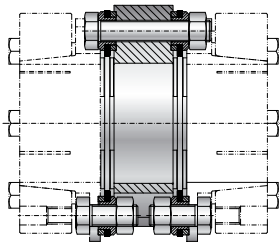

INTERMEDIATE FLANGE  
DOUBLE FLEX FOR USE WITH  
VARIOUS END HUBS

# INSTALLATION AND HANDLING INDUSTRIAL DRIVE COUPLINGS

## DIRECT DRIVES

---

### CROWNED GEAR COUPLINGS

The precise integration of the coupling hub and intermediate flange allow for low backlash and highly rigid torque transmission, while compensating for lateral, axial, and angular shaft misalignment. The crowned geometry of the gearing allows for a long life, even without the presence of misalignment.

**BZ1**

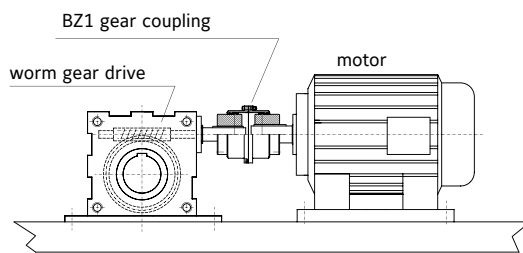

WITH KEYWAY MOUNTING  
OR CYLINDRICAL BORE FOR  
INTERFERENCE FIT

**BZA**

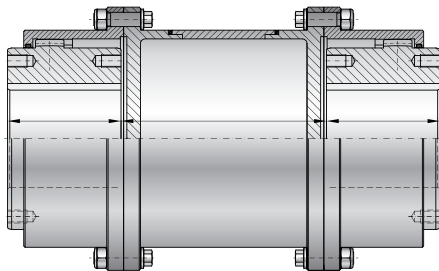

WITH INTERMEDIATE TUBE

# DIRECT DRIVES

## METAL BELLOWS COUPLINGS

R+W bellows couplings are flexible shaft couplings. The stainless steel bellows compensates for lateral, axial and angular shaft misalignment while transmitting torque with zero backlash and high torsional stiffness.

**BX1**

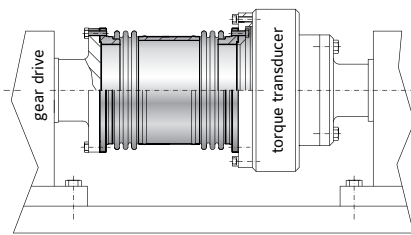

WITH FLANGE MOUNTING

**BX4**

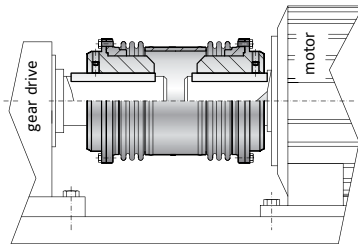

WITH KEYWAY MOUNTING

**BX6**

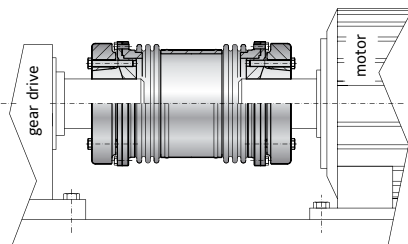

WITH CONICAL CLAMPING RINGS

# INSTALLATION AND HANDLING INDUSTRIAL DRIVE COUPLINGS

## DIRECT DRIVES

---

### ELASTIC JAW COUPLINGS

R+W elastic jaw couplings are three piece flexible shaft couplings. The elastomer inserts are preloaded into the jaws, transmitting torque with zero backlash. The coupling system also compensates for lateral, axial, and angular shaft misalignment. The elastomer inserts are available in different hardness levels in order to allow for different characteristics in terms of damping, flexibility, and torsional stiffness.

**EK1**

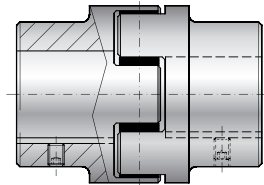

WITH SIMPLE KEYWAY  
MOUNTING

**EKH**

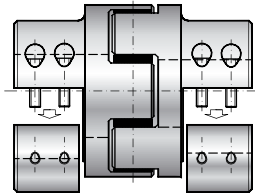

WITH FULLY SPLIT CLAMPING  
HUBS

**EK6**

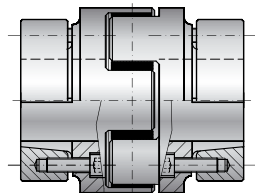

WITH CONICAL CLAMPING RINGS

## ELASTIC DRIVE SHAFT SYSTEM

R+W drive shaft systems are flexible couplings for spanning larger distances between shaft ends. The elastomer inserts compensate for lateral, axial, and angular shaft misalignment. The preloaded elastic coupling system also absorbs vibration while transmitting torque with zero backlash.

EZ2

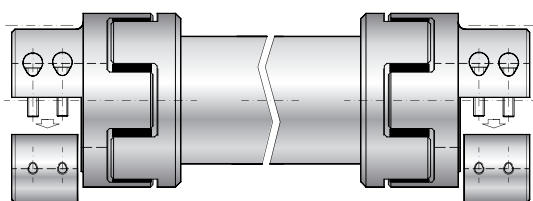

WITH FULLY SPLIT CLAMPING HUB  
AND INTERMEDIATE TUBE







# TORQSET® SAFETY COUPLINGS

## 200- 250,000 Nm



### GENERAL INFORMATION ABOUT R+W SAFETY COUPLINGS:



#### FIT CLEARANCE

Overall shaft / hub clearance of 0.02 - 0.07 mm

#### TEMPERATURE RANGE

-30 to +120° C

#### SPECIAL SOLUTIONS

Automatic re-engagement

#### ATEX (Optional)





For use in hazardous areas available upon request.

#### DISENGAGEMENT BEHAVIOR

Full disengagement / manual reset is standard.



## TORQSET® SAFETY COUPLINGS 200 – 250,000 Nm

MODEL		FEATURES	
<b>ST1</b>		<b>with simple keyway mounting for indirect drives from 200 - 250,000 Nm</b> <ul style="list-style-type: none"><li>▶ compact, simple design</li><li>▶ precise overload protection</li><li>▶ torsionally stiff</li><li>▶ integral bearing for overhung load support</li></ul>	Page 44-45
<b>STR</b>		<b>with keyway mounting special robust version from 200 - 250,000 Nm</b> <ul style="list-style-type: none"><li>▶ compact, simple design</li><li>▶ precise overload protection</li><li>▶ torsionally stiff</li><li>▶ with heavy duty bearing for overhung load support</li></ul>	Page 46-47
<b>STN</b>		<b>with conical clamping ring for indirect drives from 200 - 165,000 Nm</b> <ul style="list-style-type: none"><li>▶ high shaft clamping pressure</li><li>▶ compact, simple design</li><li>▶ precise overload protection</li><li>▶ torsionally stiff</li><li>▶ integral bearing for overhung load support</li></ul>	Page 48-49
<b>STF</b>		<b>with flange mounting both sides from 200 - 45,000 Nm</b> <ul style="list-style-type: none"><li>▶ compact design with customer specified interface for torque transducers and other mounting flanges</li><li>▶ precise overload protection</li><li>▶ torsionally stiff</li><li>▶ with special bearing for high speeds</li></ul>	Page 50

## MODEL

## FEATURES

STE



**with keyway mounting and elastomer coupling from 200 - 14,000 Nm**

- ▶ vibration damping
- ▶ precise overload protection
- ▶ wear resistant
- ▶ press fit design

Page 51

ST2



**with simple keyway mounting and elastic coupling from 200 - 165,000 Nm**

- ▶ highly elastic damping
- ▶ compensation for misalignment
- ▶ precise overload protection
- ▶ elastomer segments resistant to oil and dirt
- ▶ press fit design

Page 52-53

ST4



**with simple keyway mounting and crowned gear coupling from 200 - 250,000 Nm**

- ▶ high power density
- ▶ compensation for misalignment
- ▶ precise overload protection
- ▶ low reaction loads on shaft bearings
- ▶ extremely wear resistant

Page 54-55

ST

**Options / Special Solutions**

Page 56

ACCESSORIES

**Accessories for Safety Couplings**

Page 59 - 63

# ST1

## WITH SIMPLE KEYWAY MOUNTING

200 - 45,000 Nm



### PROPERTIES

#### MATERIAL

Hardened steel (nitrocarburized surface)

► Driven side: output flange with 12x fastening threads and integral bearings

#### DESIGN

► Drive side: coupling hub with keyway connection (spline profile on request)

► Safety elements: evenly spaced around the circumference; externally adjustable

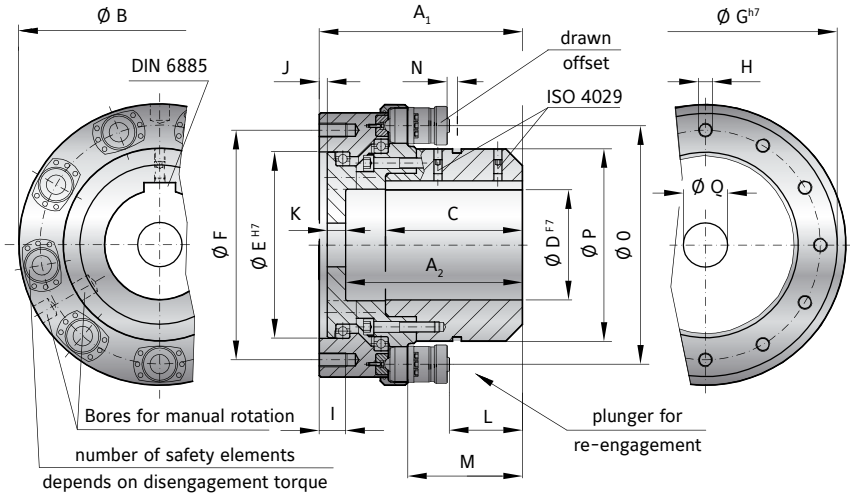

### MODEL ST1 | SIZE 2 - 40

SIZE		2			5			10			25			40		
Adjustment range available from - to (KNm)		0.2-0.5	0.5-1.0	1.0-1.5	0.7-2	1.2-4	3.2-5	2-5	4-10	6-14	6-12	9-18	15-25	12-21	22-32	32-45
		3×ST10	6×ST10	6×ST10	3×ST15	6×ST15	6×ST15	3×ST15	6×ST15	9×ST15	6×ST15	9×ST15	12×ST15	6×ST30	6×ST30	9×ST30
Overall length (mm)	A <sub>1</sub>	120			150			183			230			305		
Bore depth (mm)	A <sub>2</sub>	100			124			158			200			210		
Outside diameter (mm)	B	198			220			270			318			428		
Fit length (mm)	C	100			121			120			155			210		
Bore diameter possible Ø to Ø F7 (mm)	D	30-75			40-90			40-110			60-140			90-170		
Flange centering diameter H7 (mm)	E	132			145			170			210			270		
Bolt circle diameter ±0.3 (mm)	F	162			170			220			260			330		
Flange outside diameter h7 (mm)	G	192			209			259			298			380		
Fastening threads	H	12xM10			12xM12			12xM16			12xM16			12xM20		
Thread depth (mm)	I	15			20			25			30			35		
Fit length (mm)	J	3.5			4			6			8			8		
Wall thickness (mm)	K	15			21			17			20			28		
Distance (mm)	L	10.5			16.5			45			80			102		
Distance (mm)	M	51.5			66.5			95			130			170		
Actuation path (mm)	N	3.5			4.5			4			4			7.5		
Mounting diameter - elements (mm)	O	154			171			220			270			350		
Hub outside diameter (mm)	P	104			120			170			218			265		
Bore for fastening screw (mm)	Q	max. Ø 75			max. Ø 90			max. Ø 110			max. Ø 140			max. Ø 144		
Moment of inertia (approx.) D max. + max. sgmnt (10 <sup>-3</sup> kgm <sup>2</sup> )		77			151			370			780			3570		
Speed max. (rpm)		7000			6000			4200			3800			3000		
Allowable max. radial force standard* (kN)		5			10			20			30			40		
Approx. weight at D max. + max. sgmnt (kg)		15			24			40			63			166		

\* larger radial loads possible with special bearings

# ST1

## WITH SIMPLE KEYWAY MOUNTING

11,000 - 250,000 Nm



### PROPERTIES

#### MATERIAL

Hardened steel (nitrocarburized surface)

- ▶ Driven side: output flange with 12x fastening threads and integral bearings

#### DESIGN

- ▶ Drive side: coupling hub with keyway connection (spline profile on request)
- ▶ Safety elements: evenly spaced around the circumference; externally adjustable

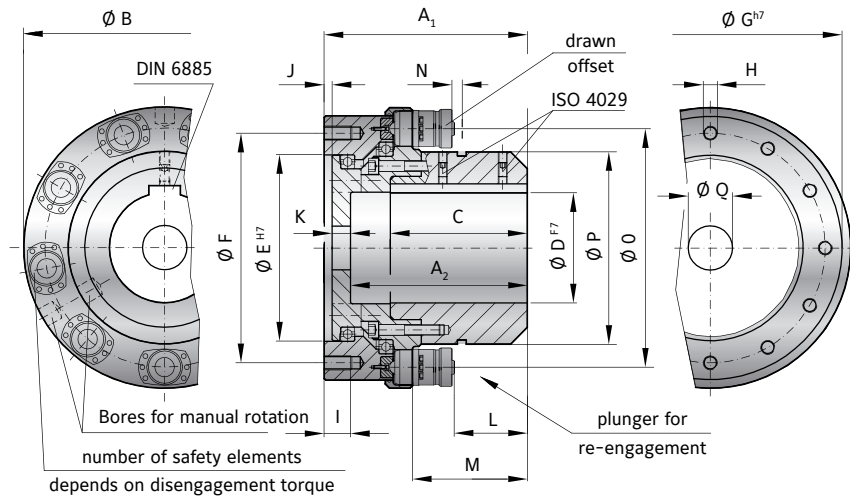

SAFETY COUPLINGS  
ST

## MODEL ST1 | SIZE 60 - 250

SIZE		60			100			160			250	
Adjustment range available from - to (KNm)		11-18	22-36	30-55	24-50	45-90	80-110	25-55	50-110	80-165	100-170	160-250
		3×ST 30	6×ST 30	9×ST 30	3×ST70	6×ST70	9×ST70	3×ST70	6×ST70	9×ST70	8×ST71	12×ST71
Overall length (mm)	A <sub>1</sub>	320			396			410			534	
Bore depth (mm)	A <sub>2</sub>	275			280			360			370	
Outside diameter	B	459			592			648			740	
Fit length (mm)	C	220			280			290			370	
Bore diameter possible Ø to Ø F7 (mm)	D	80-200			100-250			100-290			200-340	
Flange centering diameter H7 (mm)	E	300			390			450			508	
Bolt circle diameter ±0.3 (mm)	F	360			464			570			600	
Flange outside diameter h7 (mm)	G	418			530			618			680	
Fastening threads	H	12xM20			12xM24			12xM24			12xM36	
Thread depth (mm)	I	35			40			40			60	
Fit length (mm)	J	8			10			10			12	
Wall thickness (mm)	K	30			38			38			60	
Distance (mm)	L	99			128			135			135	
Distance (mm)	M	167			218			225			228	
Actuation path (mm)	N	7,5			10			10			10	
Mounting diameter - elements (mm)	O	376			490			532			630	
Hub outside diameter (mm)	P	295			380			418			508	
Bore for fastening screw (mm)	Q	max. Ø 200			max. Ø 216			max. Ø 290			max. Ø 290	
Moment of inertia (approx.) D max. + max. sgmnt (10 <sup>-3</sup> kgm <sup>2</sup> )		4600			16850			24600			56800	
Speed max. (rpm)		2500			2200			2000			1200	
Allowable max. radial force standard* (KN)		50			60			100			120	
Approx. weight at D max. + max. sgmnt (kg)		179			403			463			850	

\* larger radial loads possible with special bearings

# STR

## WITH SIMPLE KEYWAY MOUNTING, ROBUST 200 - 45,000 Nm



NEW

### PROPERTIES

#### MATERIAL

Hardened steel (nitrocarburized surface)

#### DESIGN

► Drive side: coupling hub with keyway connection (spline profile on request)

► Driven side: Output flange with attachment threads and reinforced bearings.

► Safety elements: evenly spaced around the circumference; externally adjustable

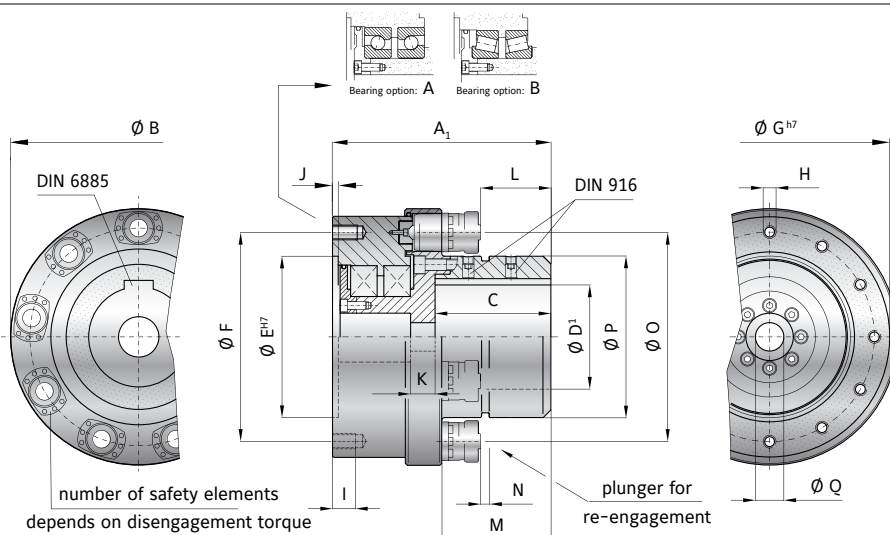

### MODEL STR | SIZE 2 - 40

SIZE		2				4				5		10			25			40			
Adjustment range available from - to (KNm)		0.2-0.5	0.5-1.0	1.0-1.5	1.5-3.5	0.6-0.9	1.1-1.7	1.6-2.6	2.5-5.0	0.7-2	1.2-4	3.2-5	2-5	4-10	6-14	9-12	9-18	15-25	12-21	22-32	32-45
		3× ST11	6× ST11	6× ST11	6× ST11	3× ST11	6× ST11	9× ST11	9× ST11	3× ST16	6× ST16	6× ST16	3× ST16	6× ST16	9× ST16	6× ST16	9× ST16	12× ST16	6× ST31	6× ST31	9× ST31
Overall length (mm)	A <sub>1</sub>	170				198				190		230			264			335			
Outside diameter (mm)	B	198				211				220		270			318			428			
Fit length (mm)	C	95				120				111		122			150			191			
Bore diameter possible $\varnothing$ to $\varnothing$ F7(mm)	D	30-80				40-100				40-90		40-110			60-140			90-170			
Flange centering diameter H7 (mm)	E	132				136				145		170			210			270			
Bolt circle diameter $\pm 0.3$ (mm)	F	162				164				170		220			260			330			
Flange outside diameter h7 (mm)	G	192				194				209		259			298			380			
Fastening threads (mm)	H	12xM10				12xM12				12xM12		12xM16			12xM16			12xM20			
Thread depth (mm)	I	18				22				22		28			30			36			
Fit length (mm)	J	4.5				3.5				3.5		6			8			6			
Wall thickness (mm)	K	16				20				24		32			32			48			
Distance (mm)	L	50.0				81.5				56.0		74			97			111			
Distance (mm)	M	81.0				112.5				96.5		115			138			171			
Actuation path (mm)	N	3.5				3.5				4.5		4.5			4.5			7.5			
Mounting diameter - elements (mm)	O	154				174				171		220			270			350			
Hub outside diameter (mm)	P	112				138				122		170			218			265			
Bore for fastening screw (mm)	Q	max. $\varnothing$ 17				max. $\varnothing$ 22				max. $\varnothing$ 25		max. $\varnothing$ 26			max. $\varnothing$ 32			max. $\varnothing$ 38			
Moment of inertia (approx.) D max. + max. sgmnt ( $10^{-3}$ kgm <sup>2</sup> )		103				130				168		484			1028			4107			
Speed max. (rpm)		8500				6800				6300		5000			4000			3600			
Allowable max. radial force standard* (kN)		10				14				20		40			60			80			
Approx. weight at D max. + max. sgmnt (kg)		21				25				28		55			86			196			

\* larger radial loads possible with special bearings

# STR

## WITH SIMPLE KEYWAY MOUNTING, ROBUST 11,000 - 250,000 Nm



NEW

### PROPERTIES

#### MATERIAL

Hardened steel (nitrocarburized surface)

#### DESIGN

► Drive side: coupling hub with keyway connection (spline profile on request)

► Driven side: Output flange with attachment threads and reinforced bearings.

► Safety elements: evenly spaced around the circumference; externally adjustable

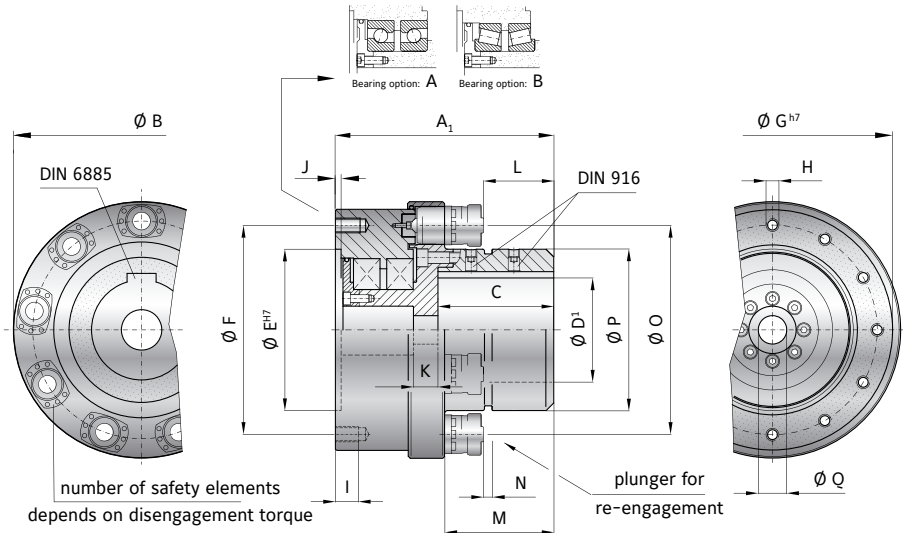

SAFETY COUPLINGS  
ST

### MODEL STR | SIZE 60 - 250

SIZE		60			100			160			250	
Adjustment range available from - to (KNm)		11-18	22-36	30-55	24-50	45-90	80-110	25-55	50-110	80-165	100-170	160-250
		3×ST31	6×ST31	9×ST31	3×ST71	6×ST71	9×ST71	3×ST71	6×ST71	9×ST71	8×ST71	12×ST71
Overall length (mm)	A <sub>1</sub>	380			470			490			600	
Outside diameter (mm)	B	459			592			648			740	
Fit length (mm)	C	220			275			282			361	
Bore diameter possible Ø to Ø F7(mm)	D	80-200			100-250			130-290			200-340	
Flange centering diameter H7 (mm)	E	300			390			450			508	
Bolt circle diameter ±0.3 (mm)	F	360			464			570			600	
Flange outside diameter h7 (mm)	G	418			530			618			680	
Fastening threads (mm)	H	12xM20			12xM24			12xM24			12xM36	
Thread depth (mm)	I	36			40			44			60	
Fit length (mm)	J	9			10			11			12	
Wall thickness (mm)	K	53.5			67.0			67.0			78.0	
Distance (mm)	L	143			179			189			273	
Distance (mm)	M	202.5			255			265			349	
Actuation path (mm)	N	7.5			10			10			10	
Mounting diameter - elements (mm)	O	376			490			532			630	
Hub outside diameter (mm)	P	295			380			420			508	
Bore for fastening screw (mm)	Q	max. Ø 44			max. Ø 44			max. Ø 52			max. Ø 52	
Moment of inertia (approx.) D max. + max. sgmnt (10 <sup>-3</sup> kgm <sup>2</sup> )		5925			20000			31830			61300	
Speed max. (rpm)		3200			2200			2000			1800	
Allowable max. radial force standard* (KN)		100			130			200			240	
Approx. weight at D max. + max. sgmnt (kg)		244			502			636			978	

\* larger radial loads possible with special bearings



#### PROPERTIES

##### MATERIAL

Hardened steel (nitrocarburized surface)

► Driven side: output flange with 12x fastening threads and integral bearings

##### DESIGN

► Drive side: coupling hub with conical clamping bushing connection (spline profile on request)

► Safety elements: evenly spaced around the circumference; externally adjustable

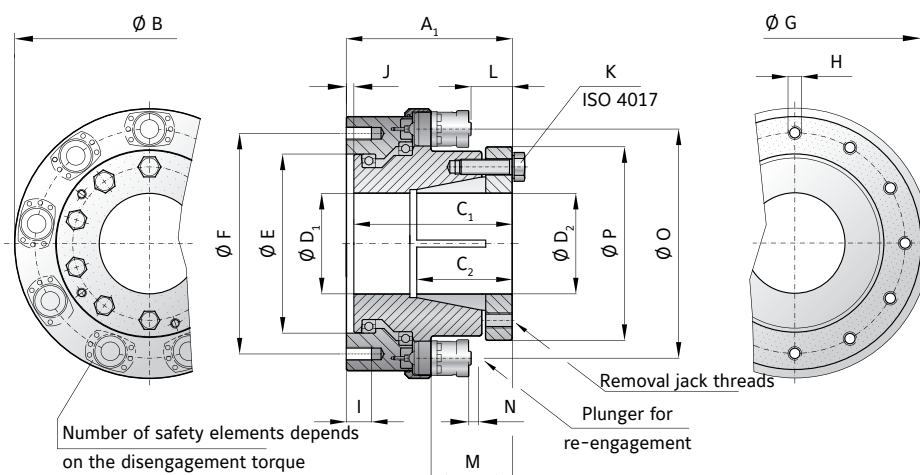

### MODEL STN | SIZE 2 - 5

SIZE		2			5		
Adjustment range available from - to	(KNm)	0.2-0.5	0.5-1.0	1.0-1.5	0.7-2	1.2-4	3.2-5
		3×ST10	6×ST10	6×ST10	3× ST15	6× ST15	6× ST15
Overall length	(mm)	A <sub>1</sub>	124.5			160	
Flange outside diameter	(mm)	B	198			220	
Fit length / keyway length	(mm)	C <sub>1</sub>	118			155	
Effective clamping length	(mm)	C <sub>2</sub>	45			82	
Bore diameter possible Ø to Ø F7	(mm)	D <sub>2</sub>	45-70			40-80	
Bore diameter max. Ø F7 with keyway	(mm)	D <sub>2</sub>	60			70	
Flange centering diameter H7	(mm)	E	132			145	
Bolt circle diameter ±0.3	(mm)	F	162			170	
Outside diameter h7	(mm)	G	192			209	
Fastening threads	(mm)	H	12×M10			12×M12	
Thread depth	(mm)	I	15			20	
Fit length	(mm)	J	3			4	
Tightening screw ISO 4017		K	6×M10			6×M10	
Tightening torque	(Nm)		59			59	
Distance	(mm)	L	18			26.5	
Distance	(mm)	M	56			76.5	
Actuation path	(mm)	N	3.5			4.5	
Mounting diameter - elements	(mm)	O	154			170	
Hub outside diameter	(mm)	P	119			136	
Moment of inertia (approx.) D max. + max. sgmnt	(10 <sup>-3</sup> kgm <sup>2</sup> )		77			151	
Speed max.	(rpm)		7000			6000	
Allowable max. radial force standard*	(KN)		5			10	
Approx. weight at D max. + max. sgmnt	(kg)		15			24	

\* larger radial loads possible with special bearings





### PROPERTIES

#### MATERIAL

Hardened steel (nitrocarburized surface)

► Driven side: output flange with 12x fastening threads and integral bearings

#### DESIGN

► Drive side: coupling hub with conical clamping ring connection (spline profile on request)

► Safety elements: evenly spaced around the circumference; externally adjustable

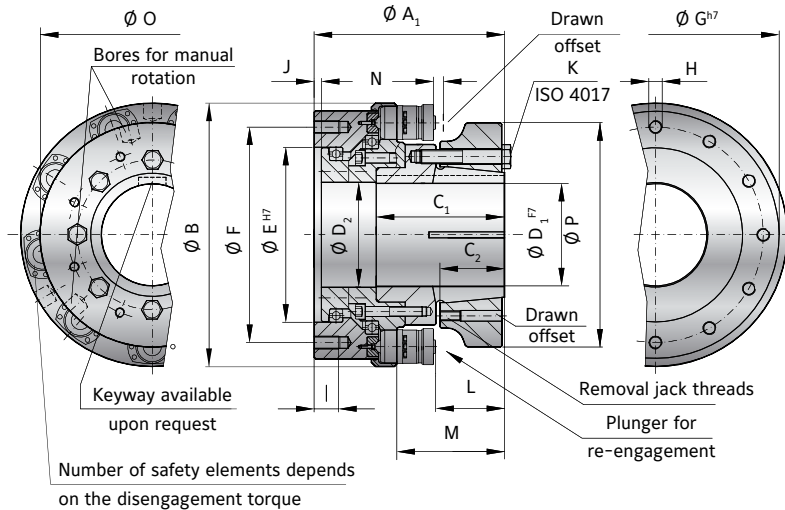

## MODEL STN | SIZE 10 - 160

SIZE		10			25			40			60			160		
Adjustment range available from - to (KNm)		2-5	4-10	6-14	6-12	9-18	15-25	12-21	22-32	32-45	11-18	22-36	30-55	25-55	50-110	80-165
		3xST15	6xST15	9xST15	6xST15	9xST15	12xST15	6xST30	6xST30	9xST30	3xST30	6xST30	9xST30	3xST70	6xST70	9xST70
Overall length (mm)	A <sub>1</sub>	210			227			286			318			425		
Flange outside diameter (mm)	B	270			318			428			459			648		
Fit length / keyway length (mm)	C <sub>1</sub>	147			152			191			218			305		
Effective clamping length (mm)	C <sub>2</sub>	62			67			93.5			93			125		
Bore diameter possible Ø to Ø F7 (mm)	D <sub>1</sub>	65-110			70-150			110-170			80-200			140-290		
Bore diameter max. Ø F7 with keyway (mm)	D <sub>1</sub>	100			140			160			180			270		
Flange centering diameter H7 (mm)	E	170			210			270			300			450		
Bolt circle diameter ±0.3 (mm)	F	220			260			330			360			570		
Outside diameter h7 (mm)	G	259			298			380			418			618		
Fastening threads (mm)	H	12xM16			12xM16			12xM20			12xM20			12xM24		
Thread depth (mm)	I	25			30			36			35			40		
Fit length (mm)	J	6			8			9			8			11		
Tightening screw ISO 4017	K	8xM16			9xM16			11xM16			8xM20			8xM24		
Tightening torque (Nm)		180			180			180			570			710		
Distance (mm)	L	72			80			82.5			94			151		
Distance (mm)	M	122			127			151			163			240		
Actuation path (mm)	N	4			4			8			7.5			10		
Mounting diameter - elements (mm)	O	220			270			350			376			532		
Hub outside diameter (mm)	P	218			278			322			378			535		
Moment of inertia (approx.) D max. + max. sgmnt (10 <sup>-3</sup> kgm <sup>2</sup> )		446			789			3570			5700			30700		
Speed max. (rpm)		4200			3800			3000			2500			2000		
Allowable max. radial force standard* (KN)		20			30			40			50			100		
Approx. weight at D max. + max. sgmnt (kg)		50			65			166			200			550		

\* larger radial loads possible with special bearings



# WITH FLANGE MOUNTING

200 - 45,000 Nm



**NEW**

## PROPERTIES

**MATERIAL**  
Hardened steel (nitrocarburized surface)

**DESIGN**  
► Drive side: Coupling hub with flange mounting

- Driven side: Mounting flange with fastening threads and integral bearing
- Safety elements: evenly spaced around the circumference; externally adjustable

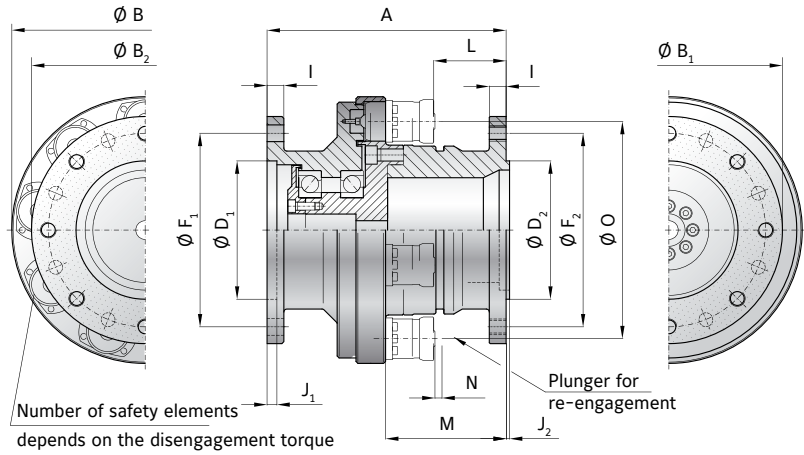

## MODEL STF | SIZE 2 - 40

SIZE		2			5			10			25			40		
Adjustment range available from to (KNm)		0.2-0.5	0.5-1.0	1.0-1.5	0.7-2	1.2-4	3.2-5	2-5	4-10	6-14	6-12	9-18	15-25	12-21	22-32	32-45
		3×ST10	6×ST10	6×ST10	3×ST15	6×ST15	6×ST15	3×ST15	6×ST15	9×ST15	6×ST15	9×ST15	12×ST15	3×ST31	6×ST31	9×ST31
Overall length (mm)	A	190			230			250			280			320		
Major outside diameter (mm)	B	198			220			270			318			428		
Flange outside diameter (mm)	B <sub>1</sub>	170			188			230			268			340		
Flange outside diameter (mm)	B <sub>2</sub>	170			188			230			306			390		
Flange centering diameter H7 (mm)	D <sub>1</sub>	90			110			140			174			210		
Flange centering diameter h7 (mm)	D <sub>2</sub>	90			110			140			200			210		
Hole circle diameter (mm)	F <sub>1</sub>	130			155.5			196			220			304		
Through hole diameter (mm)	F <sub>1</sub>	8×Ø13			8×Ø15			8×Ø17			12×Ø19			16×Ø22		
Bolt circle diameter (mm)	F <sub>2</sub>	130			155.5			196			270			350		
Thread size (mm)	F <sub>2</sub>	8×M12			8×M14			8×M16			12×M18			16×M20		
Flange thickness (mm)	I	14			17.5			20			22			25		
Fit length (mm)	J <sub>1</sub>	3			4			5			5			6		
Fit length (mm)	J <sub>2</sub>	2.5			3			3.5			4			4		
Distance (mm)	L	45			63.5			75			83.5			105.5		
Distance (mm)	M	83			113.5			125			124.5			165		
Actuation path (mm)	N	3.5			4.5			4.5			4.5			7.5		
Moment of inertia (approx.) D max. + max. sgmnt (10 <sup>-3</sup> kgm <sup>2</sup> )	J.kst	83			150			380			830			3300		
Speed max. (rpm)		9000			7500			6300			5000			3600		
Allowable max. radial force standard* (KN)		7			12			17			22			30		
Approx. weight at D max. + max. sgmnt (kg)	m.kst	20			30.4			50.3			73			180		

\* larger radial loads possible with special bearings



**NEW: ATEX**

### PROPERTIES

#### MATERIAL

- ▶ **Clutch segment:** hardened steel (nitrocarburized surface)
- ▶ **Elastomer segment:** TPU in various Shore hardnesses
- ▶ **Jaw coupling segments:** GGG40

#### DESIGN

- ▶ Drive side: coupling hub with simple keyway mounting
- ▶ Driven side: coupling hub with simple keyway mounting and elastomer segments
- ▶ Safety elements: evenly spaced around the circumference; externally adjustable

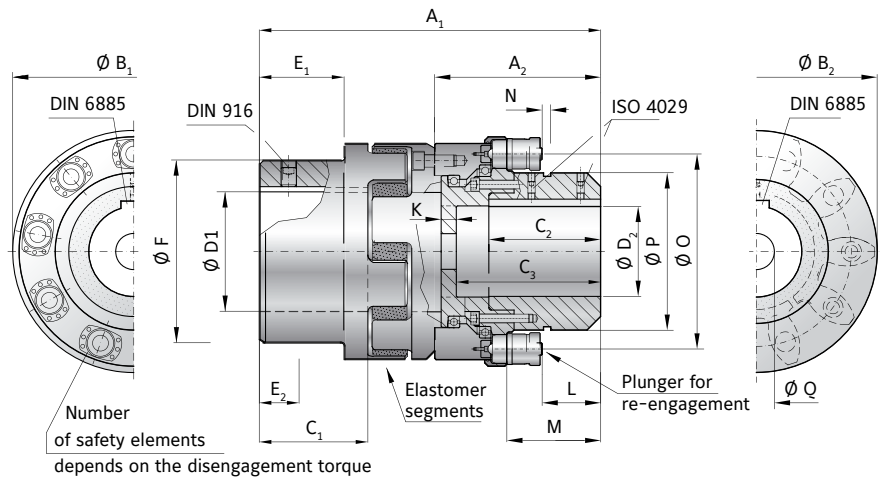

### MODEL STE | SIZE 2 - 10

SIZE		2			4			5			10		
Adjustment range available from to (KNm)		0.2-0.5 3×ST11	0.5-1.0 6×ST11	1.0-1.5 6×ST11	0.6-0.9 3×ST11	1.1-1.7 6×ST11	1.6-2.6 9×ST11	0.7-2 3×ST16	1.2-4 6×ST16	3.2-5 6×ST16	2-5 3×ST16	4-10 6×ST16	6-14 9×ST16
Elastomer coupling size		2500			2500			4500			9500		
Elastomer insert type		A / B / D			A / B / D			A / B / D			A / B / D		
Overall length ±2 (mm)	A <sub>1</sub>	312			360			373			460		
Length of torque limiting portion (mm)	A <sub>2</sub>	170			198			190			230		
Flange outside diameter (ST portion) (mm)	B <sub>1</sub>	198			211			220			270		
Flange outside diameter (elastomer portion) (mm)	B <sub>2</sub>	160			160			225			290		
Fit length/keyway length D1 (mm)	C <sub>1</sub>	88			88			113			142		
Fit length/keyway length D2 (mm)	C <sub>2</sub>	85			120			100			122		
Bore depth (torque limiting portion) (mm)	C <sub>3</sub>	95			120			111			122		
Bore diameter (elastomer portion) Ø - Ø F7 (mm)	D <sub>1</sub>	30-95			30-95			40-130			50-170		
Bore diameter (torque limiting portion) Ø - Ø F7 (mm)	D <sub>2</sub>	30-80			40-100			40-90			40-110		
Length (mm)	E <sub>1</sub>	69			69			89			110		
Length (mm)	E <sub>2</sub>	36			36			47			57		
Hub diameter (mm)	F	154			154			190			240		
Wall thickness (mm)	K	16			20			24			32		
Distance (mm)	L	50			81.5			56			74		
Distance (mm)	M	81			112.5			97			115		
Actuation path (mm)	N	3.5			3.5			4.5			4.5		
Mounting diameter - elements (mm)	O	154			174			171			220		
Hub outside diameter (mm)	P	112			138			122			170		
Bore for fastening screw (mm)	Q	max Ø17			max Ø22			max Ø25			max Ø26		
Moment of inertia (approx.) D max. + max. sgmnt (10 <sup>-3</sup> kgm <sup>2</sup> )		145			172			337			1145		
Speed max. (rpm)		8500			6800			6300			5000		
Approx. weight at D max. + max. sgmnt (kg)		35			39			47			110		
Axial (mm)		± 3			± 3			± 4			± 5		
Lateral Elastomer insert type A / B (mm)		0.5 / 0.3			0.5 / 0.3			0.5 / 0.3			0.6 / 0.4		
Angular Elastomer insert type A / B (degree)		1.5 / 1.0			1.5 / 1.0			1.5 / 1.0			1.5 / 1.0		
Dynamic torsional stiffness at T <sub>KN</sub> (Elastomer insert type A / B) (10 <sup>3</sup> Nm/rad)		175 / 216			175 / 216			337 / 743			1180 / 1340		

For technical information about the elastomer insert segments see page 97.

# ST2

## WITH SIMPLE KEYWAY MOUNTING

200 - 25,000 Nm



NEW: ATEX

### PROPERTIES

#### MATERIAL

- ▶ **Safety coupling portion:** hardened steel (nitrocarburized surface)
- ▶ **Elastomer segments:** precision molded, wear resistant rubber compound (75-80 Shore A)
- ▶ **Elastomer coupling:** hubs made from coated high strength cast steel

#### DESIGN

With keyway connection (spline profile on request). Elastomer segments compensate for misalignment and absorb vibration. Safety elements evenly spaced around the circumference. Field adjustable within the specified range.

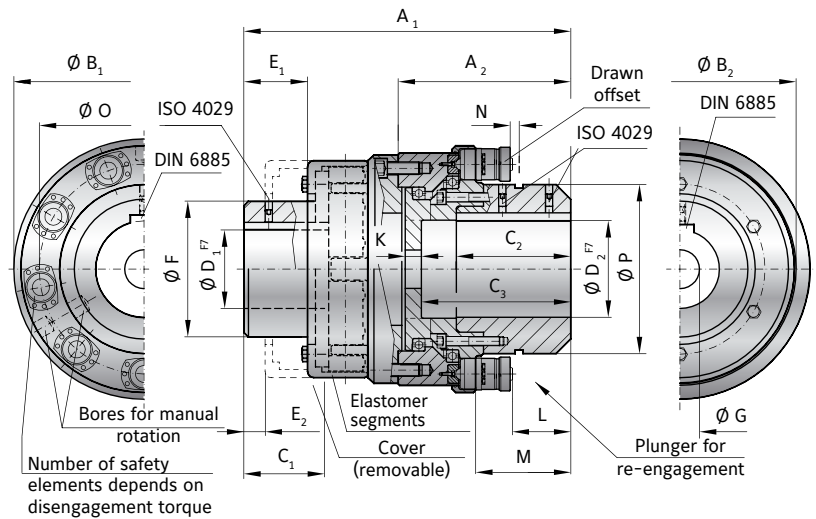

### MODEL ST2 | SIZE 2 - 25

SIZE		2			5			10			25		
Adjustment range available from - to (KNm)		0.2-0.5	0.5-1.0	1.0-1.5	0.7-2	1.2-4	3.2-5	2-5	4-10	6-14	6-12	9-18	15-25
		3×ST10	6×ST10	6×ST10	3×ST15	6×ST15	6×ST15	3×ST15	6×ST15	9×ST15	6×ST15	9×ST15	12×ST15
Overall length ±2 (mm)	A <sub>1</sub>	264			313			360			437		
Length of torque limiting portion (mm)	A <sub>2</sub>	120			150			183			230		
Flange outside diameter (ST portion) (mm)	B <sub>1</sub>	198			220			270			318		
Flange outside diameter (elastomer portion) (mm)	B <sub>2</sub>	221			250			290			330		
Fit length/keyway length D1 (mm)	C <sub>1</sub>	82			89			97			116		
Fit length/keyway length D2 (mm)	C <sub>2</sub>	100			121			120			155		
Bore depth (torque limiting portion) (mm)	C <sub>3</sub>	100			124			158			200		
Bore diameter (elastomer portion) Ø - Ø F7 (mm)	D <sub>1</sub>	30-80			40-100			40-105			60-130		
Bore diameter (torque limiting portion) Ø - Ø F7 (mm)	D <sub>2</sub>	30-75			40-90			40-110			60-140		
Length to cover (mm)	E <sub>1</sub>	65			70			70			87		
Length to (cover removed) (mm)	E <sub>2</sub>	24			23			22			26		
Hub diameter (mm)	F	130			145			160			200		
Bore for fastening screw (mm)	G	max. Ø 75			max. Ø 90			max. Ø 110			max. Ø 140		
Distance (mm)	L	10.5			16.5			45			80		
Distance (mm)	M	51.5			66.5			95			130		
Actuation path (mm)	N	3.5			4.0			4			4		
Mounting diameter - elements (mm)	O	154			171			220			270		
Hub outside diameter (mm)	P	104			120			170			218		
Moment of inertia (approx.) D max. + max. sgmnt (10 <sup>-3</sup> kgm <sup>2</sup> )		152			289			854			1850		
Speed max. (rpm)		3400			3000			2400			2000		
Approx. weight at D max. + max. sgmnt (kg)		29			43.7			93			115		
Axial (mm)		1.5			1.5			1.5			1.5		
Lateral (mm)		0.3			0.4			0.4			0.5		
Angular (degree)		1			1			1			1		
Dynamic torsional stiffness at T <sub>KN</sub> (Standard A Insert) (10 <sup>3</sup> Nm/rad)		58			92			145			230		

\* larger bore diameters upon request. | For technical information about the elastomer insert segments see page 29.

# ST2

## WITH SIMPLE KEYWAY MOUNTING

12,000 - 165,000 Nm



NEW: ATEX

### PROPERTIES

#### MATERIAL

- ▶ **Safety coupling portion:** hardened steel (nitrocarburized surface)
- ▶ **Elastomer segments:** precision molded, wear resistant rubber compound (75-80 Shore A)
- ▶ **Elastomer coupling:** hubs made from coated high strength cast steel

#### DESIGN

With keyway connection (spline profile on request). Elastomer segments compensate for misalignment and absorb vibration. Safety elements evenly spaced around the circumference. Field adjustable within the specified range.

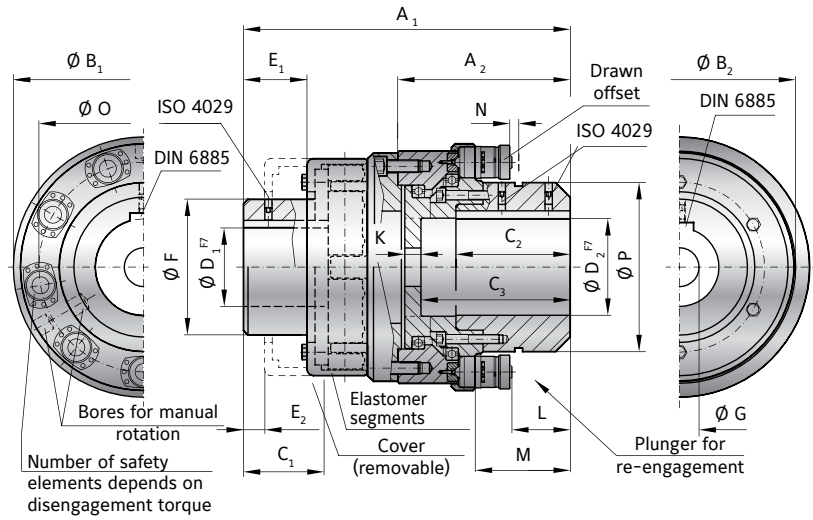

SAFETY COUPLINGS  
ST

## MODEL ST2 | SIZE 40 - 160

SIZE		40			60			100			160		
Adjustment range available from - to (KNm)		12-21	22-32	32-45	11-18	22-36	30-55	24-50	45-90	80-110	25-55	50-110	80-165
		6×ST30	6×ST30	9×ST30	3×ST 30	6×ST 30	9×ST 30	3×ST70	6×ST70	9×ST70	3×ST70	6×ST70	9×ST70
Overall length ±2 (mm)	A <sub>1</sub>	565			580			716			730		
Length of torque limiting portion (mm)	A <sub>2</sub>	305			320			396			410		
Flange outside diameter (ST portion) (mm)	B <sub>1</sub>	428			459			592			648		
Flange outside diameter (elastomer portion) (mm)	B <sub>2</sub>	432			432			553			553		
Fit length/keyway length D1 (mm)	C <sub>1</sub>	160			160			230			230		
Fit length/keyway length D2 (mm)	C <sub>2</sub>	170			220			280			290		
Bore depth (torque limiting portion) (mm)	C <sub>3</sub>	210			275			280			360		
Bore diameter (elastomer portion) Ø - Ø F7 (mm)	D <sub>1</sub>	90-170			80-160			100-200			100-200		
Bore diameter (torque limiting portion) Ø - Ø F7 (mm)	D <sub>2</sub>	90-170			80-200			100-250			100-290		
Length to cover (mm)	E <sub>1</sub>	113			112			152			152		
Length to (cover removed) (mm)	E <sub>2</sub>	39			39			65			65		
Hub diameter (mm)	F	255			255			300			300		
Bore for fastening screw (mm)	G	max. Ø 144			max. Ø 200			max. Ø 216			max. Ø 290		
Distance (mm)	L	102			99			128			135		
Distance (mm)	M	170			167			218			225		
Actuation path (mm)	N	7.5			7.5			10			10		
Mounting diameter - elements (mm)	O	350			376			490			532		
Hub outside diameter (mm)	P	265			295			380			418		
Moment of inertia (approx.) D max. + max. sgmnt (10 <sup>-3</sup> kgm <sup>2</sup> )		6010			8960			21890			36858		
Speed max. (rpm)		1800			1800			1500			1500		
Approx. weight at D max. + max. sgmnt (kg)		271			287			642			729		
Axial (mm)		2			2			2.5			2.5		
Lateral (mm)		0.6			0.6			0.7			0.7		
Angular (degree)		1			1			1			1		
Dynamic torsional stiffness at T <sub>KN</sub> (Standard A Insert) (10 <sup>3</sup> Nm/rad)		500			580			850			1000		

\* larger bore diameters upon request. | For technical information about the elastomer insert segments see page 29.

# ST4

## WITH SIMPLE KEYWAY MOUNTING

200 - 25,000 Nm



### PROPERTIES

#### MATERIAL

- ▶ **Safety coupling portion:** hardened steel (nitrocarburized surface)
- ▶ **Gear coupling portion:** wear resistant high strength alloy steel (nitrocarburized surface)

#### DESIGN

With keyway connection (spline profile on request). Gear coupling for misalignment compensation. Safety elements evenly spaced around the circumference. Field adjustable within the specified range.

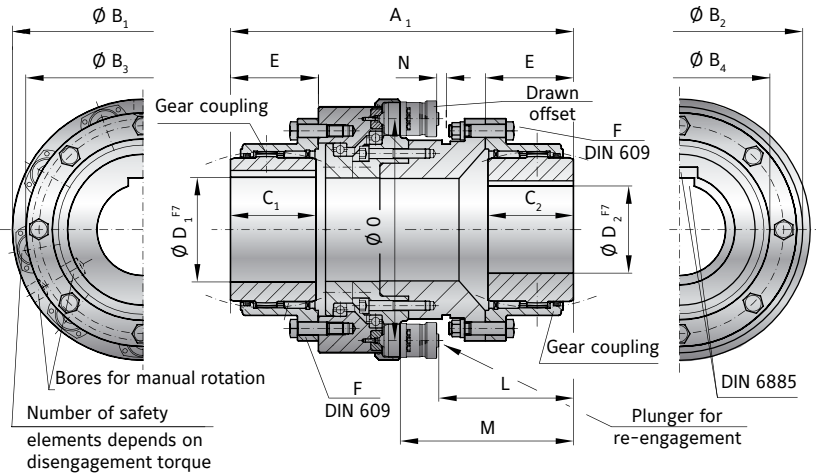

## MODEL ST4 | SIZE 2 - 25

SIZE		2			5			10			25		
Adjustment range available from - to (kNm)		0.2-0.5	0.5-1.0	1.0-1.5	0.7-2	1.2-4	3.2-6	2-5	4-10	6-14	6-12	9-18	15-25
		3×ST10	6×ST10	6×ST10	3×ST15	6×ST15	6 ST15	3×ST15	6×ST15	9×ST15	6×ST15	9× ST15	12×ST15
Overall length (mm)	$A_1$	280			350			390			460		
Flange outside diameter (ST portion) (mm)	$B_1$	198			220			270			318		
Mounting flange outside diameter (ST portion) (mm)	$B_2$	192			209			259			300		
Flange outside diameter (gear coupling) (mm)	$B_3$	168			200			225			265		
Hub diameter (gear coupling) (mm)	$B_4$	130.5			158.4			183.4			211.5		
Fit length/keyway length (mm)	$C_{1/2}$	62			76			90			105		
Bore diameter $\varnothing$ to $\varnothing F7$ (mm)	$D_{1/2}$	30-78			32-98			42-112			46-132		
Length (mm)	$E$	63.5			78.5			92.5			108		
Screw (mm)	$F$	6×M8			10×M12			12×M12			12×M16		
Tightening torque (mm)	$F$	18			65			65			150		
Distance (mm)	$L$	110			138			159.5			202		
Distance (mm)	$M$	148			188			209.5			252		
Actuation path (mm)	$N$	3.5			4.5			4.5			4.5		
Mounting diameter - elements (mm)	$O$	154			171			220			270		
Moment of inertia (approx.) D max. + max. sgmnt ( $10^{-3}$ kgm <sup>2</sup> )		108			244			529			1117		
Speed max. (rpm)		4000			3900			3700			3550		
Approx. weight at D max. + max. sgmnt (kg)		25			45			65			100		
Axial (mm)		1.5			2.5			2.5			3		
Angular (Degrees)		2×0.35°			2×0.35°			2×0.35°			2×0.35°		

\* Larger bore diameters upon request. | For technical information about the gear coupling segments see page 19.

# ST4

## WITH SIMPLE KEYWAY MOUNTING

12,000 - 250,000 Nm



### PROPERTIES

#### MATERIAL

- **Safety coupling portion:** hardened steel (nitrocarburized surface)
- **Gear coupling portion:** wear resistant high strength alloy steel (nitrocarburized surface)

#### DESIGN

With keyway connection (spline profile on request). Gear coupling for misalignment compensation. Safety elements evenly spaced around the circumference. Field adjustable within the specified range.

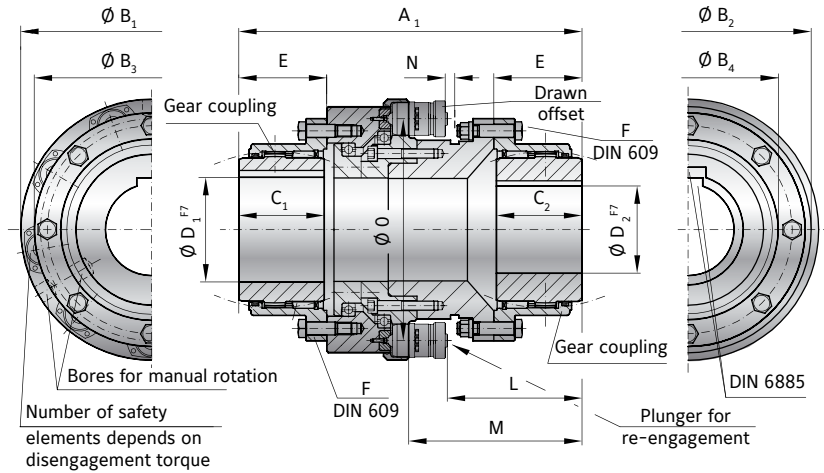

SAFETY COUPLINGS  
ST

## MODEL ST4 | SIZE 40 - 250

SIZE	40			60			100			160			250	
Adjustment range available from - to (kNm)	12-21	22-32	32-45	11-18	22-36	30-55	24-50	45-90	80-110	25-55	50-110	80-165	100-170	160-250
	6×ST30	6×ST30	9×ST30	3×ST30	6×ST30	9×ST30	3×ST70	6×ST70	9×ST70	3×ST70	6×ST70	9×ST70	8×ST71	12×ST71
Overall length (mm)	$A_1$	580			650			780			860			1060
Flange outside diameter (ST portion) (mm)	$B_1$	428			459			592			648			740
Mounting flange outside diameter (ST portion) (mm)	$B_2$	399			418			560			618			724
Flange outside diameter (gear coupling) (mm)	$B_3$	330			370			438			525			639
Hub diameter (gear coupling) (mm)	$B_4$	275.5			307			367			423			553
Fit length/keyway length (mm)	$C_{1/2}$	135			150			190			220			290
Bore diameter $\varnothing$ to $\varnothing F7$ (mm)	$D_{1/2}$	60-174			70-190			110-233			120-280			200-340
Length (mm)	$E$	139			154			194			225			296
Screw (mm)	$F$	14×M16			14×M18			14×M22			16×M24			22×M24
Tightening torque (mm)	$F$	150			220			400			520			670
Distance (mm)	$L$	238			275			318			360			458
Distance (mm)	$M$	306			343			408			450			534
Actuation path (mm)	$N$	8			8			10			10			10
Mounting diameter - elements (mm)	$O$	350			376			490			532			630
Moment of inertia (approx.) D max. + max. sgmnt ( $10^{-3}$ kgm <sup>2</sup> )		4363			6650			20611			33820			84926
Speed max. (rpm)		2750			2420			1950			1730			950
Approx. weight at D max. + max. sgmnt (kg)		225			293			570			718			1280
Axial (mm)		4			4			4			5			6
Angular (Degrees)		2×0.35°			2×0.35°			2×0.35°			2×0.35°			2×0.35°

\* larger bore diameters upon request. | For technical information about the gear coupling segments see page 19.





# OPTIONS / SPECIAL SOLUTIONS

## SAFETY COUPLINGS - FURTHER POSSIBILITIES

---

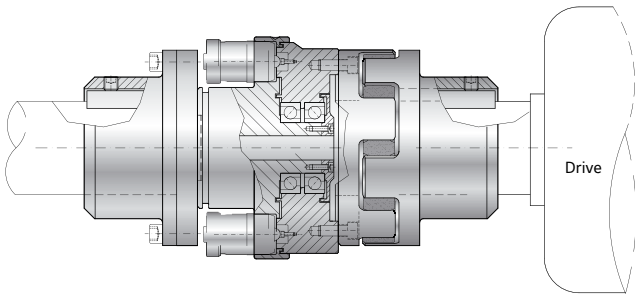

### FOR EXTRUDER APPLICATIONS

- ▶ with elastic jaw coupling
- ▶ precise overload protection
- ▶ removable center section for lateral mounting

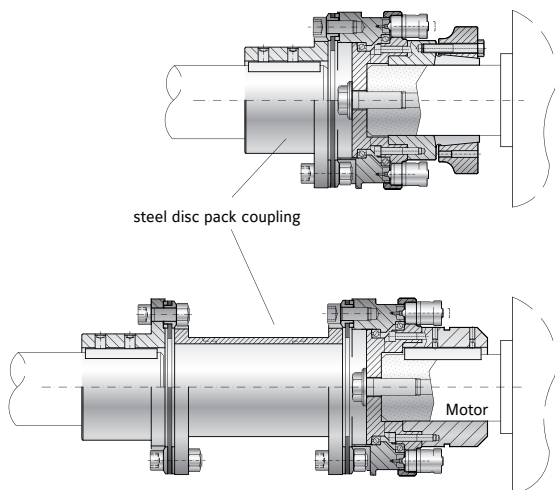

### WITH TORSIONALLY STIFF DISC PACK COUPLING

- ▶ single or double flex
- ▶ high torsional stiffness
- ▶ disc packs from highly elastic spring steel



### WITH TORSIONALLY STIFF BELLOWS COUPLING

- ▶ with clamping hubs, keyway mounting or flange mounting
- ▶ compensation for misalignment
- ▶ bellows made from highly elastic stainless steel





## FOR HIGH SPEED APPLICATIONS

- ▶ integral ball-plunger system
- ▶ extremely compact with a low moment of inertia
- ▶ balanced for high speed



## BUREAU VERITAS CERTIFIED

- ▶ for inland and offshore applications
- ▶ customized solutions
- ▶ rugged and special design for direct use in ship powertrains

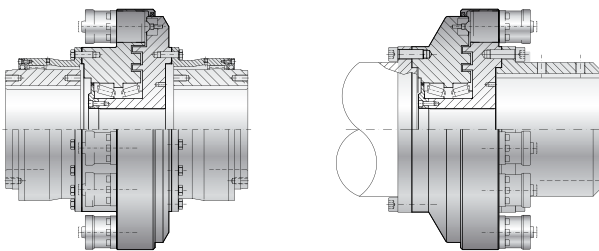

## MORE DESIGNS AVAILABLE

- ▶ for 1,000,000 Nm and more
- ▶ customer specified solutions
- ▶ for all branches and industries



# TORQSET® SAFETY COUPLINGS ACCESSORIES

# ST

## SAFETY ELEMENT



### PROPERTIES

#### MATERIAL

Hardened steel (nitrocarburized surface)

#### DESIGN

Two part assembly for installation into prefabricated coupling components.

Part 1: detent receptacle

Part 2: self-contained, spring loaded plunger module.

The spring force setting is adjustable in the field, with the settings clearly marked on an adjustment scale.

#### FIT TOLERANCE

For insertion of the safety elements H7 precision holes should be used for all centered components.

#### RE-ENGAGEMENT

When properly located over the detent receptacle the safety element can be re-engaged through the application of pressure to the back side of the plunger core.

Design:

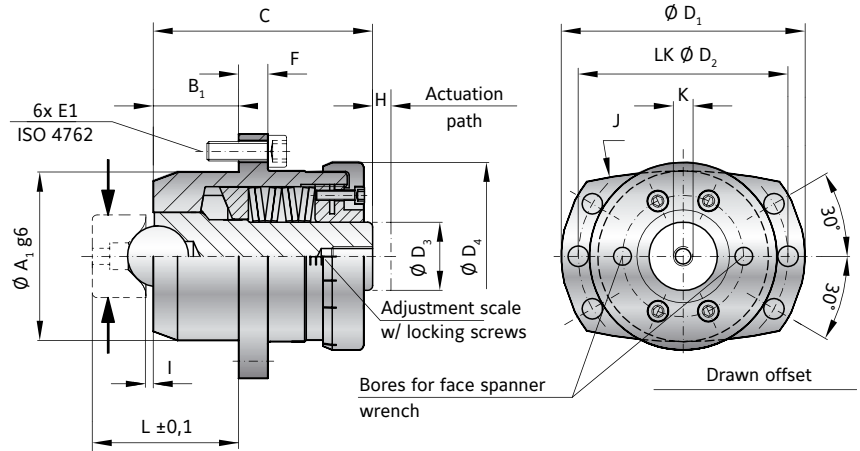
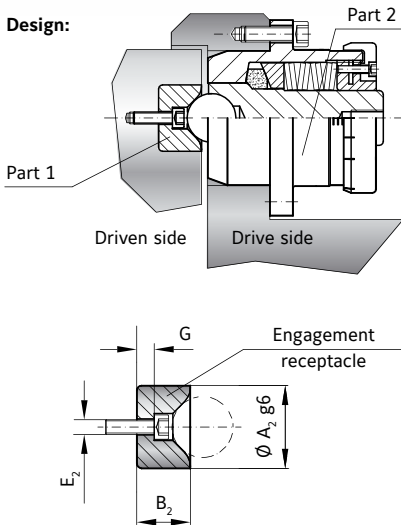

### MODEL ST | SIZE 10 - 70

SIZE		10	15	30	70
Tangential force (KN) Adjustment range available from - to (ranges)	1	0.8-2.2	1-4   2-8   6-15	5-10   10-20   20-32	8-20
	2	-	2-8	10-20	15-40
	3	2.0-3.3	6-20	20-30	30-70
Centering diameter of safety element g6 (mm)	A <sub>1</sub>	28	40	70	90
Centering diameter engagement receptacle g6 (mm)	A <sub>2</sub>	18	24	34	44
Centering length of safety element (mm)	B <sub>1</sub>	15	20	35	45
Centering length engagement receptacle (mm)	B <sub>2</sub>	13.5	14	22	30
Overall length (mm)	C	56	70	103	135
Outside diameter (mm)	D <sub>1</sub>	45	59	100	129
Bolt circle diameter (mm)	D <sub>2</sub>	37.5	50	86	110
Diameter plunger (mm)	D <sub>3</sub>	8	16	28	35
Diameter adjustment nut (mm)	D <sub>4</sub>	32	44	75	92
Screw / Tightening torque ISO 4762 (mm)	E <sub>1</sub>	6 x M4 x 12 / 4.5 Nm	6 x M5 x 16 / 10 Nm	6 x M8 x 25 / 40 Nm	6 x M12 x 35 / 120 Nm
Screw / Tightening torque ISO 4762 (mm)	E <sub>2</sub>	M3 x 20 4.5 Nm	M4 x 14 4.5 Nm	M6 x 20 15.5 Nm	M8 x 25 38 Nm
Flange thickness (mm)	F	5	7	12	16
Distance (mm)	G	6.5	5	8	10
Actuation path (mm)	H	3	4	7.5	10
Distance (mm)	I	1.5	2	3	4
Radius (mm)	J	100	110	200	250
Inner thread (mm)	K	M5 x 10	M8 x 15	M10 x 25	M16 x 30
Distance ± 0,1 (mm)	L	30	36	60	79
Weight (kg)		0.26	0.65	2.7	6

axial spring force = tangential force/1.4

ORDERING EXAMPLE	ST	30	2	12	XX
Model	●				
Size		●			
Adjustment range 1/2/3			●		
Tangential force (KN)				●	
For custom features place an XX at the end of the part number and describe the special requirements (e.g. ST / 30 / 2 / 12 / XX)					

# ACCESSORIES ST

## TORQSET® SAFETY COUPLINGS

### ENGAGEMENT AND DISENGAGEMENT

ST

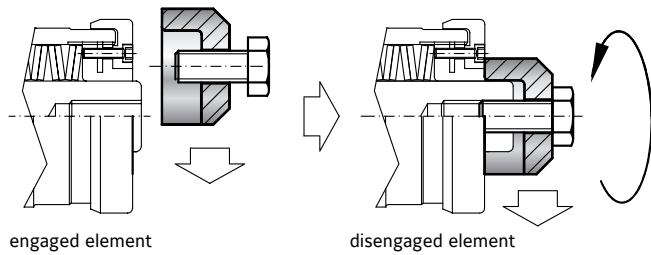

### ORDER NUMBER

SIZE	ENGAGEMENT / DISENGAGEMENT TOOL
10	Order number AV / 0010
15	Order number AV / 0015
30	Order number AV / 0030
70	Order number AV / 0070

### ADJUSTMENT WRENCH

ST

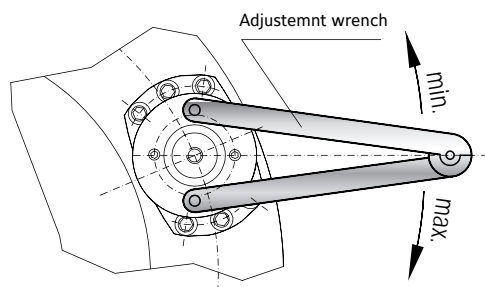

### ORDER NUMBER

SIZE	ADJUSTMENT WRENCH
10	Order number SLS / 0010
15	Order number SLS / 0015
30	Order number SLS / 0030
70	Order number SLS / 0070

### SWITCH PLATE

ST

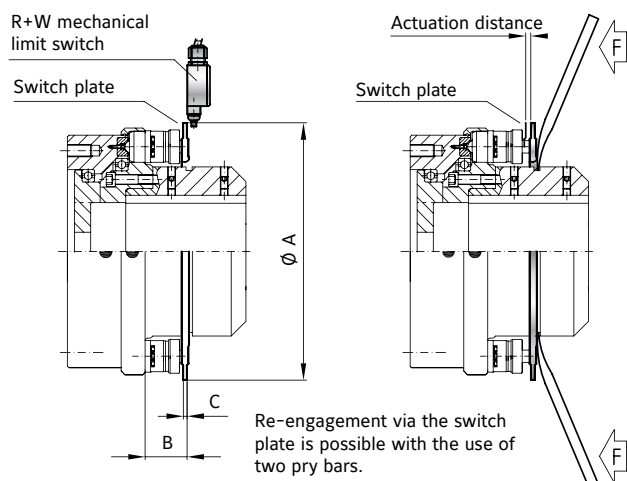

Switch plates are available on request for all sizes and series.

Contact R+W for more information.

SAFETY COUPLINGS  
ST

# ACCESSORIES ST

## TORQSET® SAFETY COUPLINGS

It is important the switches be 100% tested for proper functioning after mounting with safety coupling.

### PROXIMITY SWITCH (E-STOP FUNCTION)

ST

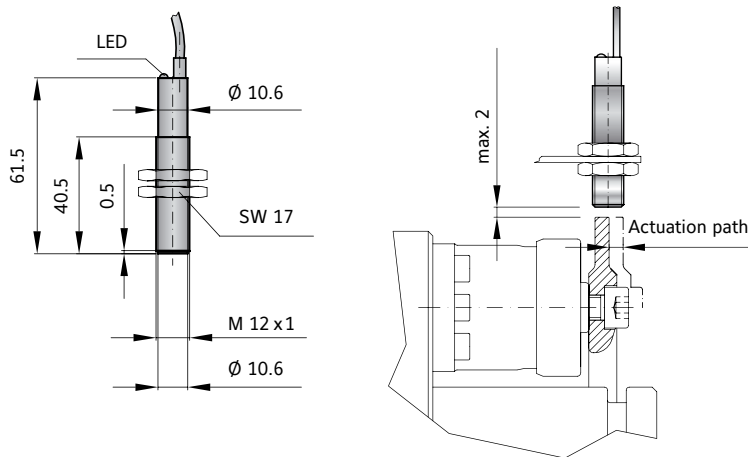

ORDER NUMBER 650.2703.001

TECHNICAL DATA	ST
Voltage	10 to 30 V DC
Max. output current	200 mA
Max. switch frequency	800 KHz
Temperature range	-25° to +70° C
Protective system	IP 67
Switch type	normally open
Max. detection gap	max. 2 mm

#### SWITCH DIAGRAM ST

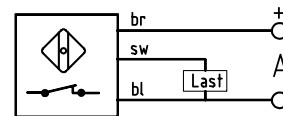

### MECHANICAL LIMIT SWITCH (E-STOP FUNCTION)

ST

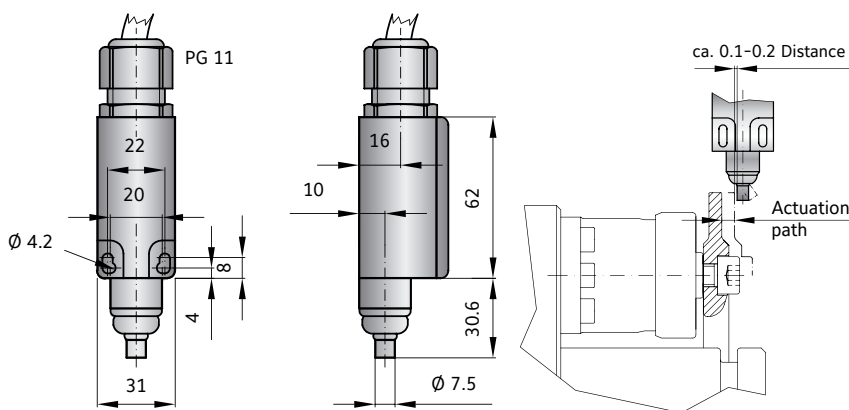

ORDER NUMBER 618.6740.644

TECHNICAL DATA	ST
Max. voltage	250 V AC
Max. constant current	2.5h A
Protective system	IP 65
Contact system	Opener (forced separating)
Temperature range	-30° to +80° C
Actuation	Plunger (metal)

#### SWITCH DIAGRAM ST

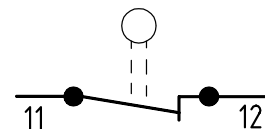

The switch plunger (pictured above and right) should be located as close to the actuation ring / limit switch plate as possible (approximately 0.1-0.2mm).

It is important the switches be 100% tested for proper functioning after mounting with safety coupling.

ATEX LIMIT SWITCH (E-STOP FUNCTION)

ORDER NUMBER EEX. 1624.004

ST

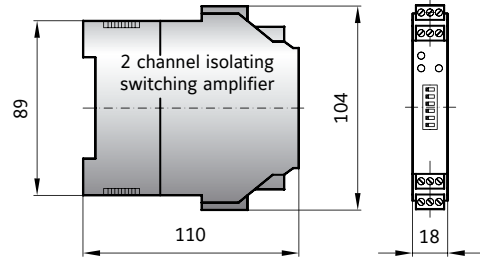
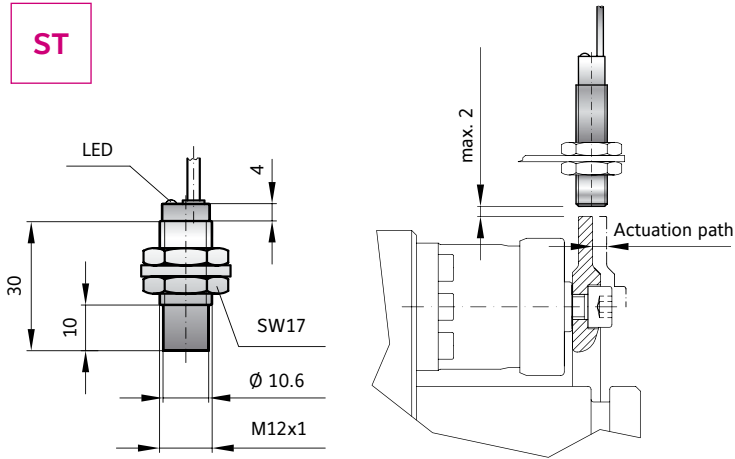

SAFETY COUPLINGS  
ST

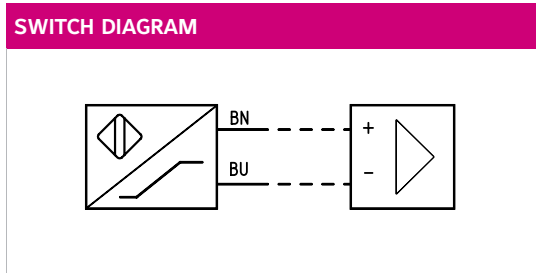
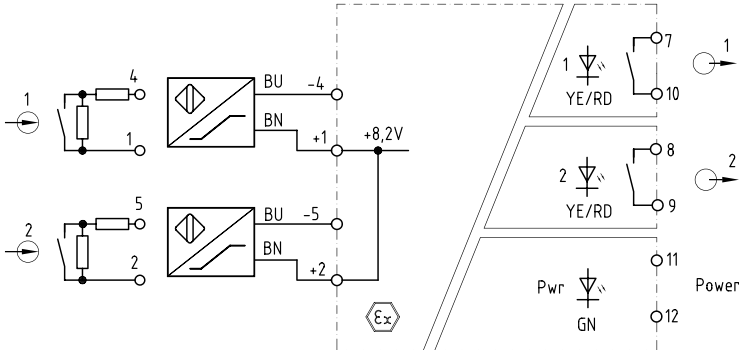

Technical data on request.









# TORSIONALLY STIFF DISC PACK COUPLINGS

## 350 – 50,000 Nm



### GENERAL INFORMATION ABOUT R+W DISC PACK COUPLINGS:



#### SERVICE LIFE

R+W disc pack couplings are fatigue resistant and wear free for an infinite service life, as long as the technical limits are not exceeded.

#### FIT CLEARANCE

Overall shaft / hub clearance of 0.01 - 0.05 mm

#### TEMPERATURE RANGE

-30 to +280° C

#### ROTATIONAL SPEED

see table

#### DELIVERY







LP couplings are delivered with the disc packs pre-assembled. They need only to be mounted to the hubs.

#### ATEX (Optional)

For use in hazardous areas available upon request.



## TORSIONALLY STIFF DISC PACK COUPLINGS 350 – 50,000 Nm

MODEL		FEATURES	
<b>LP1</b>		<b>with keyway mounting from 350 - 50,000 Nm</b> <ul style="list-style-type: none"><li>▶ very high torsional stiffness</li><li>▶ single flex design</li><li>▶ compact layout</li><li>▶ compensates for axial and angular misalignment</li></ul>	Page 68-69
<b>LP2</b>		<b>with keyway mounting from 350 - 50,000 Nm</b> <ul style="list-style-type: none"><li>▶ high torsional stiffness</li><li>▶ double flex design</li><li>▶ customer specified length available</li><li>▶ compensates for axial, angular, and lateral misalignment</li></ul>	Page 70-71
<b>LPA</b>		<b>with keyway mounting for API 610 pump systems from 500 - 24,000 Nm</b> <ul style="list-style-type: none"><li>▶ API 610 / 671</li><li>▶ intermediate cartridge for lateral mounting</li><li>▶ safety catch for in case of disc pack rupture</li><li>▶ metric or imperial dimensions available</li></ul>	Page 72-73
<b>LPAI</b>			
<b>LP3</b>		<b>with conical clamping ring from 500 - 50,000 Nm</b> <ul style="list-style-type: none"><li>▶ high torsional stiffness</li><li>▶ high clamping pressure</li><li>▶ backlash free torque transmission</li><li>▶ good for high speed, reversing and intermittent loading</li></ul>	Page 74
<b>LP4</b>		<b>with conical clamping ring from 500 - 50,000 Nm</b> <ul style="list-style-type: none"><li>▶ very high torsional stiffness</li><li>▶ single flex design</li><li>▶ compact layout</li><li>▶ compensates for axial and angular misalignment</li></ul>	Page 75
<b>LPZ</b>		<b>intermediate flange from 500 - 50,000 Nm</b> <ul style="list-style-type: none"><li>▶ very high torsional stiffness</li><li>▶ double flex design</li><li>▶ for use with various end hubs</li></ul>	Page 76
<b>LP</b>		<b>Options / Special Solutions</b>	Page 77

# DESIGN

## DISC PACK COUPLINGS

R+W disc pack couplings transmit torque across the disc pack assemblies purely by friction, thus avoiding stress concentration, backlash, and micro-movements resulting from transmitting torque across shoulder bolts. This aids in approaching infinite life in addition to making the complete coupling assembly more torsionally stiff.



### MISALIGNMENT COMPENSATION

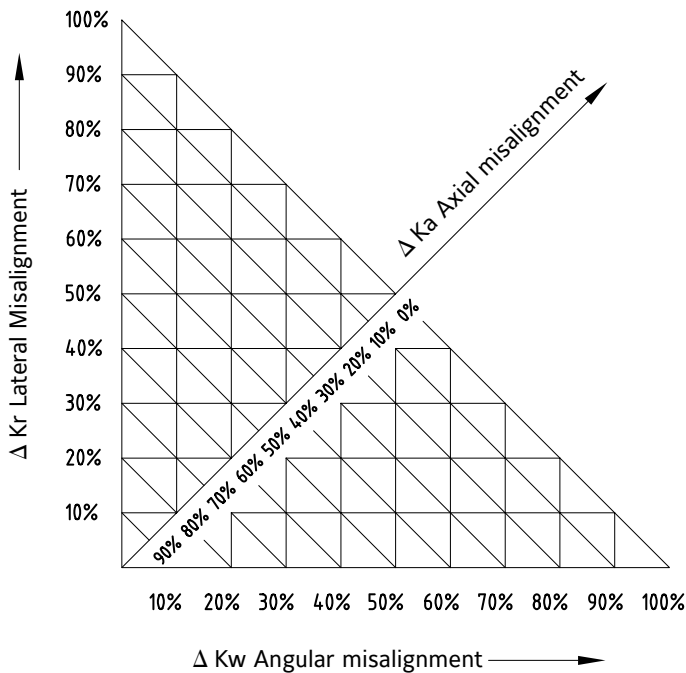

$$\Delta K_{total} = \Delta K_r + \Delta K_w + \Delta K_a \leq 100\%$$

These couplings compensate for varying combinations of shaft misalignment types as percentages of the total allowable misalignment values listed in the data tables. The total sum of the three misalignment percentages must not exceed 100%.

**Example: pump skid**

- axial misalignment: 20%
- lateral misalignment: 40%
- angular misalignment: 40%

$$\Delta K_{total} = 20\% + 40\% + 40\% \leq 100\%$$

➔ coupling is fatigue resistant

# LP1

## WITH KEYWAY MOUNTING

350 - 5,000 Nm



### PROPERTIES

#### FEATURES

- ▶ very high torsional stiffness
- ▶ single flex design
- ▶ wear and maintenance free

#### MATERIAL

- ▶ **Disc pack:** highly elastic spring steel
- ▶ **Hubs:** high strength steel

#### DESIGN

Two precision machined coupling hubs mounted to the disc pack by means of high strength screws and bushings for alignment and frictional clamping of the assembly. Axial retention of the hubs with DIN 916 set screws

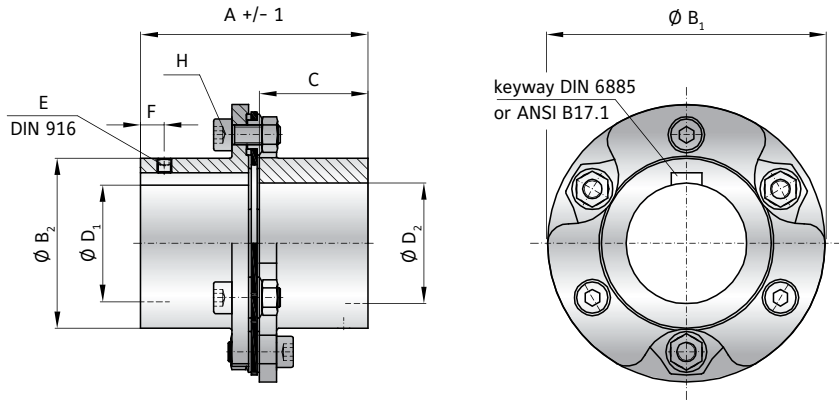

## MODEL LP1 | SIZE 300 - 2500

SIZE			300	500	700	800	2000	2500
Rated torque	(Nm)	$T_{KN}$	350	500	700	800	2000	2500
Maximum torque	(Nm)	$T_{Kmax}$	700	1000	1400	1600	4000	5000
Overall length	(mm)	A	95	95	116	116	158	160
Outside diameter	(mm)	$B_1$	99	115	128	141	150	188
Hub diameter	(mm)	$B_2$	63	71	78	84	86	102
Hub fit length	(mm)	C	45	45	55	55	75	76
Bore diameter available from $\emptyset$ to $\emptyset$ H7	(mm)	$D_{1/2}$	18-48	23 - 50	25-58	25 - 60	28-64	31 - 75
Set screw (DIN 916)		E	M5	M6	M5	M6	M5	M8
Distance to screw	(mm)	F	15	7	15	10	20	14
Assembly screw (ISO 4762) Nut (DIN 934)		H	M8	M8	M10	M10	M16	M16
Tightening torque	(Nm)		41	41	83	83	355	355
Moment of inertia ( $10^{-3} \text{kgm}^2$ )		$J_{ges.}$	1.8	3.1	5.6	8.1	13.9	30
Material			Steel	Steel	Steel	Steel	Steel	Steel
Approximate weight	(kg)		2	2.7	3.8	4.8	6.7	10.5
Torsional stiffness ( $10^3 \text{Nm/rad}$ )		$C_T$	470	500	1200	1250	1500	1700
Axial $\pm$	(mm)		0.5	0.6	0.75	0.8	1	1.1
Angular $\pm$	(degree)		0.7	0.7	0.7	0.7	0.7	0.7
Maximum speed	(1/min.)		10000	10000	8000	8000	6000	6000

ORDERING EXAMPLE	LP1	800	116	25	56	XX
Model	●					Special designation only (e.g. special bore tolerance).
Size		●				
Overall length mm			●			
Bore D1 H7				●		
Bore D2 H7					●	
For custom features place an XX at the end of the part number and describe the special requirements (e.g. LP1 / 800 / 116 / 25 / 56 / XX)						

# LP1

## WITH KEYWAY MOUNTING

4,500 – 50,000 Nm



### PROPERTIES

#### FEATURES

- ▶ very high torsional stiffness
- ▶ single flex design
- ▶ wear and maintenance free

#### MATERIAL

- ▶ **Disc pack:** highly elastic spring steel
- ▶ **Hubs:** high strength steel

#### DESIGN

Two precision machined coupling hubs mounted to the disc pack by means of high strength screws and bushings for alignment and frictional clamping of the assembly. Axial retention of the hubs with DIN 916 set screws.

**50,000 Nm on request**

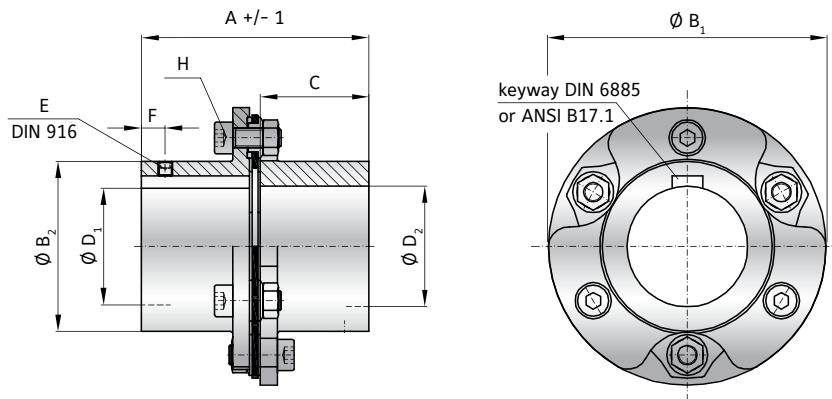

### MODEL LP1 | SIZE 4000 - 12000

SIZE			4000	5000	7000	8000	10000	12000
Rated torque (Nm)	$T_{KN}$		4500	5000	7600	8000	10000	12000
Maximum torque (Nm)	$T_{Kmax}$		9000	10000	15200	16000	20000	24000
Overall length (mm)	A		193	193	216	216	268	268
Outside diameter (mm)	$B_1$		198	227	238	294	298	320
Hub diameter (mm)	$B_2$		120	130	140	160	194	192
Hub fit length (mm)	C		90	90	100	100	125	125
Bore diameter available from $\emptyset$ to $\emptyset$ H7 (mm)	$D_{1/2}$		38-90	39 - 95	50-102	50 - 115	70-140	70 - 140
Set screw (DIN 916)	E		M8	M10	M10	M10	M12	M12
Distance to screw (mm)	F		20	15	25	15	30	20
Assembly screw (ISO 4762) Nut (DIN 934)	H		M20	M20	M24	M24	M24	M24
Tightening torque (Nm)			690	690	1200	1200	1200	1200
Moment of inertia ( $10^{-3}kgm^2$ )	$J_{GSS}$		52.2	90	127	278	412	534
Material			Steel	Steel	Steel	Steel	Steel	Steel
Approximate weight (kg)			13.3	20	20.9	37	41.4	57.8
Torsional stiffness ( $10^3Nm/rad$ )	$C_T$		3600	4000	6000	6000	13300	14000
Axial $\pm$ (mm)			1.25	1.25	1.25	1.25	1.5	1.5
Angular $\pm$ (degree)			0.7	0.7	0.7	0.7	0.7	0.7
Maximum speed (1/min.)			5000	5000	4500	4500	4000	4000

ORDERING EXAMPLE	LP1	7000	216	58	88	XX
Model	●					Special designation only (e.g. special bore tolerance).
Size		●				
Overall length mm			●			
Bore D1 H7				●		
Bore D2 H7					●	

For custom features place an XX at the end of the part number and describe the special requirements (e.g. LP1 / 7000 / 216 / 58 / 88 / XX)

# LP2

## WITH KEYWAY MOUNTING

350 - 5,000 Nm

### PROPERTIES



#### FEATURES

- ▶ high torsional stiffness
- ▶ double flex design
- ▶ customer specified length available

#### MATERIAL

- ▶ **Disc packs:** highly elastic spring steel
- ▶ **Hubs and spacer:** high strength steel

#### DESIGN

Two precision machined coupling hubs and precision spacer tube mounted to the disc packs by means of high strength screws and bushings for alignment and frictional clamping of the assembly. Axial retention with DIN 916 set screws.

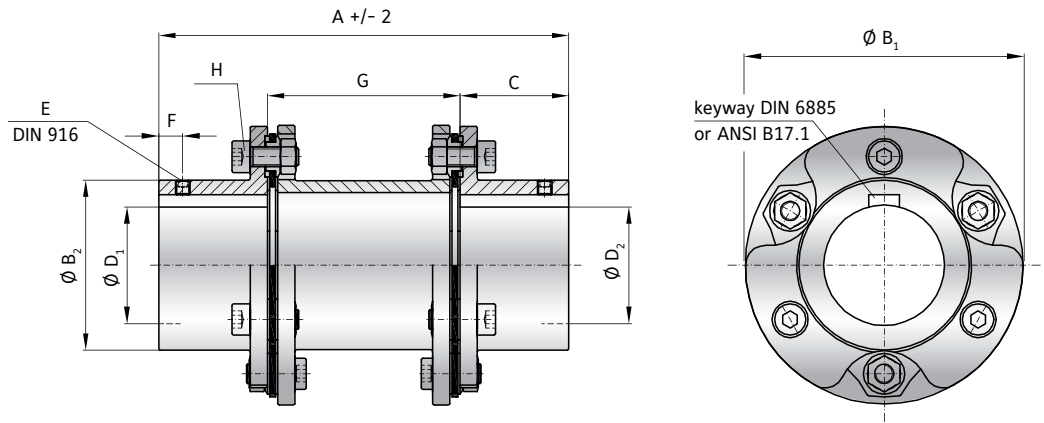

### MODEL LP2 | SIZE 300 - 2500

SIZE			300	500	700	800	2000	2500
Rated torque (Nm)	$T_{KN}$		350	500	700	800	2000	2500
Maximum torque (Nm)	$T_{Kmax}$		700	1000	1400	1600	4000	5000
Overall length (mm)	A		170	170	206	206	286	286
Outside diameter (mm)	$B_1$		99	116	128	142	150	190
Hub diameter (mm)	$B_2$		63	71	78	84	86	102
Hub fit length (mm)	C		45	45	55	55	75	76
Bore diameter available from $\emptyset$ to $\emptyset$ H7 (mm)	$D_{1/2}$		18-48	23 - 50	25-58	25 - 60	28-64	31 - 75
Set screw (DIN 916)	E		M5	M6	M5	M6	M6	M8
Distance to screw (mm)	F		15	7	15	10	20	14
Distance (mm)	G		80	80	96	96	136	134
Assembly screw (ISO 4762) Nut (DIN 934)	H		M8	M8	M10	M10	M16	M16
Tightening torque (Nm)			41	41	83	83	355	355
Moment of inertia ( $10^{-3}$ kgm <sup>2</sup> )	$J_{ges.}$		3	6	7	15.3	25	55.5
Material			Steel	Steel	Steel	Steel	Steel	Steel
Approximate weight (kg)			3	4.4	4.7	7.6	11	16.2
Torsional stiffness ( $10^3$ Nm/rad)	$C_T$		220	230	550	570	700	900
Axial $\pm$ (mm)			1	1	1.5	1.5	2	2
Lateral $\pm$ (mm)			0.8	0.8	1	1	1.4	1.4
Angular $\pm$ (degree)			1	1	1	1	1	1
Maximum speed (1/min.)			10000	10000	8000	8000	6000	6000

ORDERING EXAMPLE	LP2	500	170	25	49	XX
Model	●					Special designation only (e.g. special bore diameter tolerances).
Size		●				
Overall length mm			●			
Bore D1 H7				●		
Bore D2 H7					●	
For custom features place an XX at the end of the part number and describe the special requirements (e.g. LP2 / 500 / 170 / 25 / 49 / XX)						

# LP2

## WITH KEYWAY MOUNTING

4,500 - 50,000 Nm

### PROPERTIES



#### FEATURES

- ▶ high torsional stiffness
- ▶ double flex design
- ▶ customer specified length available

#### MATERIAL

- ▶ **Disc packs:** highly elastic spring steel
- ▶ **Hubs and spacer:** high strength steel

#### DESIGN

Two precision machined coupling hubs and precision spacer tube mounted to the disc packs by means of high strength screws and bushings for alignment and frictional clamping of the assembly. Axial retention with DIN 916 set screws. **50,000 Nm on request**

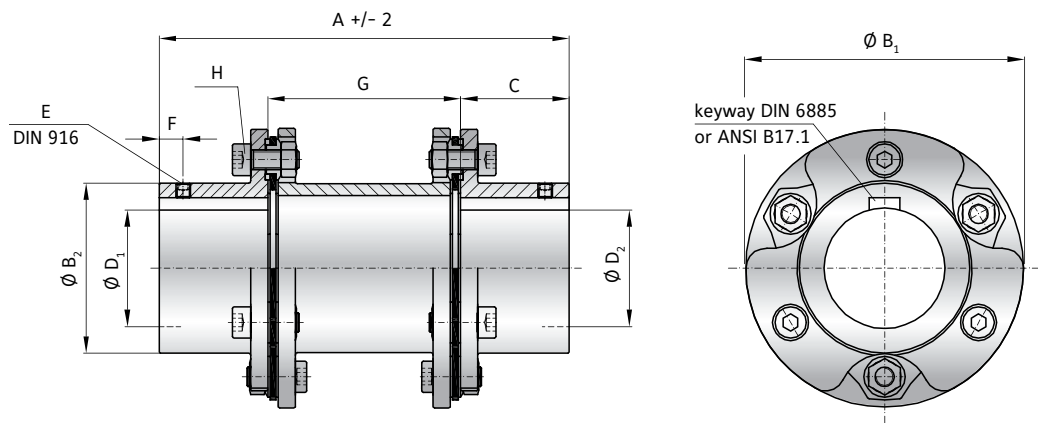

### MODEL LP2 | SIZE 4000 - 12000

SIZE			4000	5000	7000	8000	10000	12000
Rated torque (Nm)	$T_{KN}$		4500	5000	7600	8000	10000	12000
Maximum torque (Nm)	$T_{Kmax}$		9000	10000	15200	16000	20000	24000
Overall length (mm)		A	320	340	370	400	470	470
Outside diameter (mm)		$B_1$	198	231	238	298	298	324
Hub diameter (mm)		$B_2$	120	130	140	160	194	192
Hub fit length (mm)		C	90	90	100	100	125	125
Bore diameter available from $\emptyset$ to $\emptyset$ H7 (mm)		$D_{1/2}$	38-90	39 - 95	50-102	50 - 115	70-140	70 - 140
Set screw (DIN 916)		E	M8	M10	M10	M10	M12	M12
Distance to screw (mm)		F	20	15	25	15	30	20
Distance (mm)		G	140	160	170	200	220	220
Assembly screw (ISO 4762) Nut (DIN 934)		H	M20	M20	M24	M24	M24	M24
Tightening torque (Nm)			690	690	1200	1200	1200	1200
Moment of inertia ( $10^{-3}kgm^2$ )		$J_{ges.}$	89.3	170	230	553	721	933
Material			Steel	Steel	Steel	Steel	Steel	Steel
Approximate weight (kg)			20.7	31.9	35	60.3	68.8	85.4
Torsional stiffness ( $10^3Nm/rad$ )		$C_T$	1700	1900	2800	3100	6200	7000
Axial $\pm$ (mm)			2.5	2.5	2.5	2.5	3	3
Lateral $\pm$ (mm)			1.4	1.5	1.6	1.6	2.2	2.2
Angular $\pm$ (degree)			1	1	1	1	1	1
Maximum speed (1/min.)			5000	5000	4500	4500	4000	4000

ORDERING EXAMPLE	LP2	7000	370	52	88	XX
Model	●					Special designation only (e.g. special bore diameter tolerances).
Size		●				
Overall length mm			●			
Bore D1 H7				●		
Bore D2 H7					●	

For custom features place an XX at the end of the part number and describe the special requirements (e.g. LP2 / 7000 / 370 / 52 / 88 / XX)

DISC PACK COUPLINGS  
LP

PROPERTIES



FEATURES

- ▶ lateral mounting without moving hubs
- ▶ integral safety catch in case of disc pack rupture
- ▶ balanced in accordance with ANSI / AGMA 9000 class 9

MATERIAL

- ▶ **Disc packs:** highly elastic, corrosion resistant spring steel

▶ **Hubs and spacer:** high strength steel

DESIGN

Two precision machined coupling hubs and precision spacer tube mounted to the disc packs by means of high strength screws and bushings for alignment and frictional clamping of the assembly. Axial retention with DIN 916 set screws (interference fit on request).

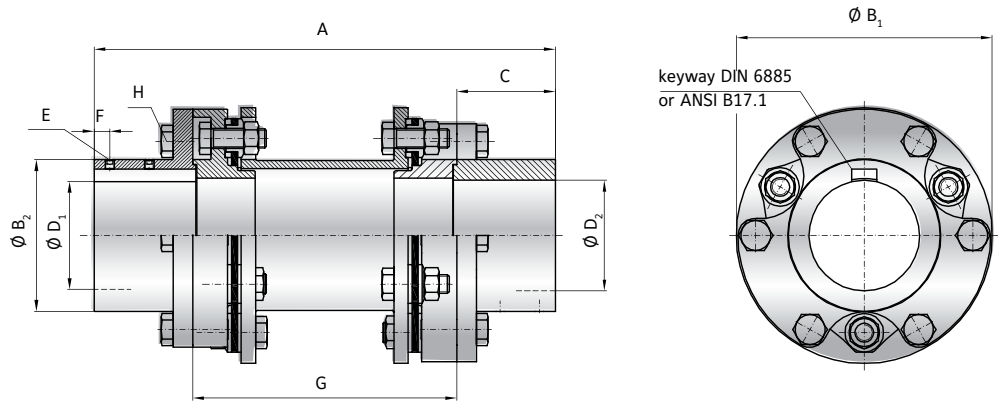

MODEL LPA | SIZE 500 - 12000

SIZE	500		800		2500		5000		8000		12000	
Rated torque (kW/100rpm)	5		8		26.2		52		84		126	
Rated torque (Nm)	500		800		2500		5000		8000		12000	
Maximum torque (Nm)	1000		1600		5000		10000		16000		24000	
Overall length (mm)	A	190	230	250	290	332	402	360	430	450	500	
Outside diameter (mm)	B <sub>1</sub>	116		142		190		231		298		324
Hub diameter (mm)	B <sub>2</sub>	71		84		102		130		160		192
Hub fit length (mm)	C	45		55		75		90		100		125
Bore diameter available from Ø to Ø H7 (mm)	D <sub>1/2</sub>	23 - 50		25 - 60		31 - 75		39 - 95		50 - 115		70 - 140
Set screw (DIN 916)	E	2 × M6		2 × M6		2 × M8		2 × M10		2 × M10		2 × M12
Distance (mm)	F	7		10		14		15		15		20
Spacer length (mm)	G	100	140	140	180	180	250	180	250	250	250	
Assembly screw (ISO 4762) Nut (DIN 934)	H	M8		M10		M16		M20		M24		M24
Tightening torque (Nm)		41		83		355		690		1200		1200
Moment of inertia (10 <sup>-3</sup> kgm <sup>2</sup> )		8	8.4	21.8	22.3	85.8	88.4	248	256	901	1350	
Material		Steel		Steel		Steel		Steel		Steel		Steel
Approximate weight (kg)		5	5.4	9.2	9.6	20.8	22	39	41	83	105	
Axial ± (mm)		0.75		1		1.3		1.5		1.7		2
Lateral ± (mm)		0.7	1.1	1	1.5	1.3	2	1.1	1.9	1.5	1.5	
Angular ± (degree)		1°		1°		1°		1°		1°		1°
maximum speed (1/min.)		7600		6400		5300		3900		3100		2500
maximum speed (balanced) (1/min.)		18800		15100		12800		9800		8100		6200

ORDERING EXAMPLE	LPA	800	250	42	38	XX
Model	●					Special designation only (e.g. special hub for large bore).
Size		●				
Overall length mm			●			
Bore D1 H7				●		
Bore D2 H7					●	
For custom features place an XX at the end of the part number and describe the special requirements (e.g. LPA / 800 / 250 / 42 / 38 / XX)						



**PROPERTIES**

**FEATURES**

- ▶ lateral mounting without moving hubs
- ▶ integral safety catch in case of disc pack rupture
- ▶ balanced in accordance with ANSI / AGMA 9000 class 9

**MATERIAL**

- ▶ **Disc packs:** highly elastic, corrosion resistant spring steel

- ▶ **Hubs and spacer:** high strength steel

**DESIGN**

Two precision machined coupling hubs and precision spacer tube mounted to the disc packs by means of high strength screws and bushings for alignment and frictional clamping of the assembly. Axial retention with DIN 916 set screws (interference fit on request).

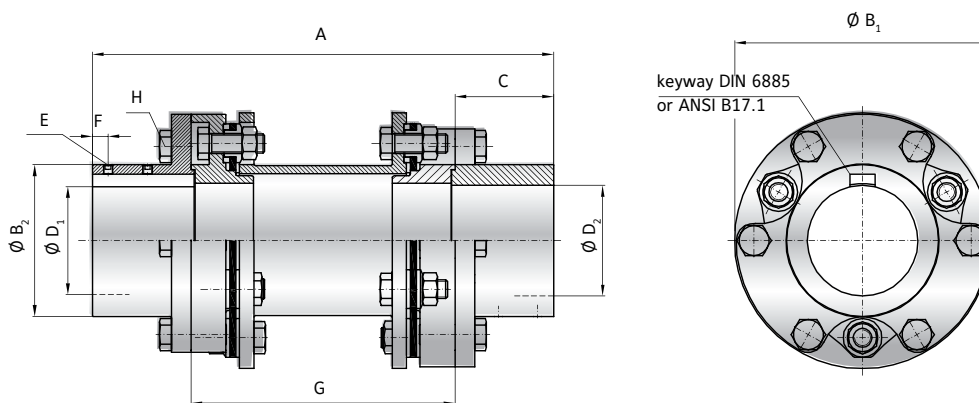

**MODEL LPAI | SIZE 500 - 12000**

SIZE	500		800		2500		5000		8000		12000	
Rated torque (kW/100rpm)	5		8		26.2		52		84		126	
Rated torque (Nm)	500		800		2500		5000		8000		12000	
Maximum torque (Nm)	1000		1600		5000		10000		16000		24000	
Overall length (mm)	217	268	237	288	330	381	358	409	429	479	429	479
Outside diameter (mm)	116		142		190		231		298		324	
Hub diameter (mm)	71		84		102		130		160		192	
Hub fit length (mm)	45		55		75		90		100		125	
Bore diameter available from Ø to Ø H7 (mm)	23 - 50		25 - 60		31 - 75		39 - 95		50 - 115		70 - 140	
Set screw	2 x 1/4"-20		2 x 1/4"-20		2 x 5/16"-18		2 x 3/8"-16		2 x 1/2"-13		2 x 1/2"-13	
Distance (mm)	7		10		14		15		15		20	
Spacer length (mm)/(in.)	127/5"	178/7"	127/5"	178/7"	178/7"	229/9"	178/7"	229/9"	229/9"	229/9"	229/9"	229/9"
Assembly screw, bolt and nut (Grade 9)	5/16"-18		3/8"-16		5/8"-11		3/4"-10		1"-8		1"-8	
Tightening torque (Nm)	38		68		320		595		1100		1100	
Moment of inertia (10 <sup>-3</sup> kgm <sup>2</sup> )	8.3	8.8	21	22.3	85	87	248	254	890	1344	890	1344
Material	Steel		Steel		Steel		Steel		Steel		Steel	
Approximate weight (kg)	5.3	5.7	9.1	9.6	20.8	21.6	38.9	40	82.3	104	82.3	104
Axial ± (mm)	0.75		1		1.3		1.5		1.7		2	
Lateral ± (mm)	1	1.5	0.9	1.4	1.3	1.8	1.1	1.6	1.3	1.6	1.3	1.3
Angular ± (degree)	1°		1°		1°		1°		1°		1°	
maximum speed (1/min.)	7600		6400		5300		3900		3100		2500	
maximum speed (balanced) (1/min.)	18800		15100		12800		9800		8100		6200	

ORDERING EXAMPLE	LPAI	800	237	25.4	50.8	XX
Model	●					
Size		●				
Overall length mm			●			
Bore D1 H7				●		
Bore D2 H7					●	
Special designation only (e.g. special hub for large bore).						
For custom features place an XX at the end of the part number and describe the special requirements (e.g. LPAI / 800 / 237 / 41.28 / 19 / XX; XX = D2 interference fit)						

DISC PACK COUPLINGS LP

# LP3

## WITH CONICAL CLAMPING RING

500 - 50,000 Nm



### PROPERTIES

#### FEATURES

- ▶ high torsional stiffness
- ▶ high clamping pressure
- ▶ backlash free torque transmission
- ▶ good for high speed, reversing and intermittent loading

#### DESIGN

Two precision machined conical clamping ring hubs and precision spacer tube mounted to the disc packs by means of high strength screws and bushings for alignment and frictional clamping of the assembly.

#### MATERIAL

- ▶ **Disc packs:** highly elastic spring steel
- ▶ **Hubs and spacer:** high strength steel

**50,000 Nm on request**

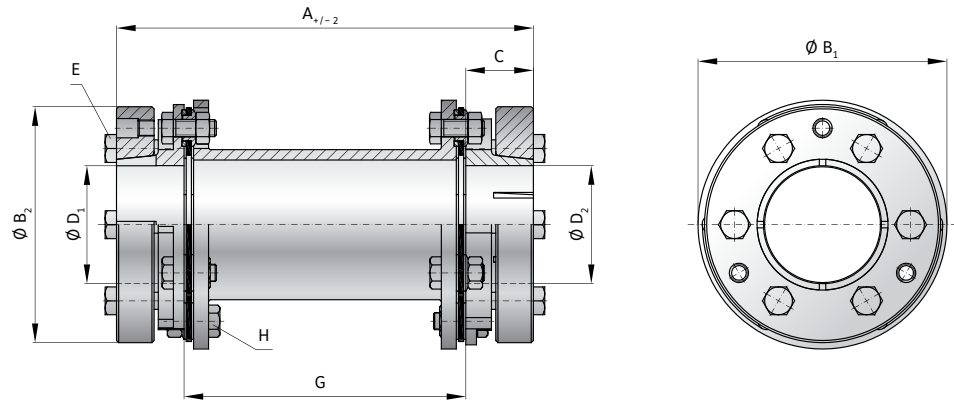

## MODEL LP3 | SIZE 500 - 12000

SIZE			500	800	2500	5000	8000	12000
Rated torque (Nm)	$T_{KN}$		500	800	2500	5000	8000	12000
Maximum torque (Nm)	$T_{Kmax}$		1000	1600	5000	10000	16000	24000
Overall length (mm)	A		143	180	265	316	410	440
Outside diameter (mm)	$B_1$		116	142	190	231	298	324
Hub diameter (mm)	$B_2$		110	130	165	205	260	290
Hub fit length (mm)	C		31.5	42	64	78	105	112
Bore diameter* available from $\emptyset$ to $\emptyset$ H7 (mm)	$D_{1/2}$		24-55	30-65	35-80	50-110	60-130	70-170
Clamping screws (ISO 4017)	E		6 x M8	6 x M10	6 x M12	6 x M12	6 x M20	6 x M20
Tightening torque (Nm)			35	69	120	295	580	580
Distance (mm)	G		80	96	137	160	200	220
Assembly screw (ISO 4762) Nut (DIN 934)	H		M8	M10	M16	M20	M24	M24
Tightening torque (Nm)			41	83	355	690	1200	1200
Moment of inertia ( $10^{-3}$ kgm <sup>2</sup> )	$J_{ges.}$		8	22	85	244	881	1393
Material			Steel	Steel	Steel	Steel	Steel	Steel
Approximate weight (kg)			4.6	8.5	20.3	36	81.5	98.2
Torsional stiffness ( $10^3$ Nm/rad)	$C_T$		230	570	900	1900	3100	7000
Axial $\pm$ (mm)			1	1.5	2	2.5	2.5	3
Lateral $\pm$ (mm)			0.8	1	1.4	1.5	1.6	2.2
Angular $\pm$ (degree)			1	1	1	1	1	1
Maximum speed (1/min.)			10000	8000	6000	5000	4500	4000

\* transmittable torque can depend on the bore diameter (contact supplier for details)

ORDERING EXAMPLE	LP3	500	143	42	38	XX
Model	●					Special designation only (e.g. special bore tolerance).
Size		●				
Overall length			●			
Bore D1 H7				●		
Bore D2 H7					●	
For custom features place an XX at the end of the part number and describe the special requirements (e.g. LP3 / 500 / 143 / 42 / 38 / XX)						

# LP4

## WITH CONICAL CLAMPING RING

500 – 50,000 Nm



NEW

### PROPERTIES

#### FEATURES

- ▶ very high torsional stiffness
- ▶ single flex design
- ▶ backlash free for reversing loads

#### MATERIAL

- ▶ **Disc pack:** highly elastic spring steel
- ▶ **Hubs:** high strength steel

#### DESIGN

Two precision machined conical clamping ring hubs mounted to the disc pack by means of high strength screws and bushings for alignment and frictional clamping of the assembly.

**50,000 Nm on request**

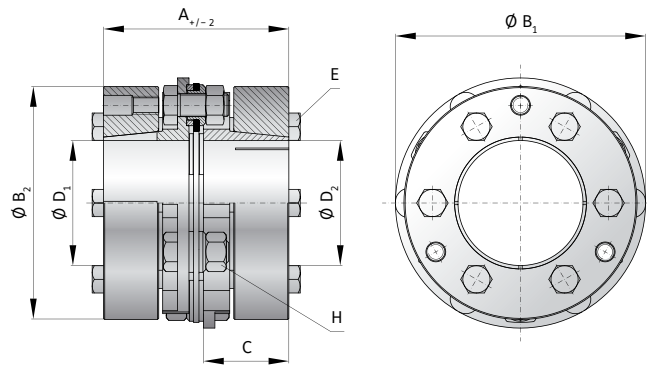

## MODEL LP4 | SIZE 500 – 12000

SIZE			500	800	2500	5000	8000	12000
Rated torque (Nm)	$T_{KN}$		500	800	2500	5000	8000	12000
Maximum torque (Nm)	$T_{Kmax}$		1000	1600	5000	10000	16000	24000
Overall length (mm)	A		68	91	137	169	226	241.5
Outside diameter (mm)	$B_1$		112	136	172	220	270	305
Hub diameter (mm)	$B_2$		110	130	165	205	260	290
Hub fit length (mm)	C		31.5	42	64	78	105	112
Bore diameter* available from $\phi$ to $\phi$ H7 (mm)	$D_{1/2}$		24 - 55	30 - 65	35 - 80	50 - 110	60 - 130	70 - 170
Clamping screws (ISO 4017)	E		6 x M8	6 x M10	6 x M12	6 x M16	6 x M20	6 x M20
Tightening torque (Nm)			25	50	100	250	470	500
Assembly screw (ISO 4017) Nut (DIN 934)	H		M8	M10	M16	M20	M24	M24
Tightening torque (Nm)			41	83	355	690	1200	1200
Moment of inertia ( $10^{-3} \text{kgm}^2$ )	$J_{ges.}$		5	15	59	172	606	993
Material			Steel	Steel	Steel	Steel	Steel	Steel
Approximate weight (kg)			2.9	5.8	14.4	25.4	58	70.6
Torsional stiffness ( $10^3 \text{Nm/rad}$ )	$C_T$		500	1250	1700	3800	6400	13800
Axial $\pm$ (mm)			0.6	0.8	1.1	1.25	1.25	1.5
Angular $\pm$ (degree)			0.7	0.7	0.7	0.7	0.7	0.7
Maximum speed (1/min.)			10000	8000	6000	5000	4500	4000

\* transmittable torque can depend on the bore diameter (contact supplier for details)

ORDERING EXAMPLE	LP4	500	68	42	38	XX
Model	●					Special designation only (e.g. special bore tolerance).
Size		●				
Overall length			●			
Bore D1 H7				●		
Bore D2 H7					●	
For custom features place an XX at the end of the part number and describe the special requirements (e.g. LP4 / 500 / 68 / 42 / 38 / XX)						

DISC PACK COUPLINGS  
LP

**LPZ**

# INTERMEDIATE FLANGE

500 - 50,000 Nm



**NEW**

## PROPERTIES

### FEATURES

- ▶ very high torsional stiffness
- ▶ double flex design
- ▶ for use with various end hubs

### DESIGN

Intermediate flange for use with different types of hubs.

**50,000 Nm on request**

### MATERIAL

- ▶ **Intermediate flange:** high strength steel

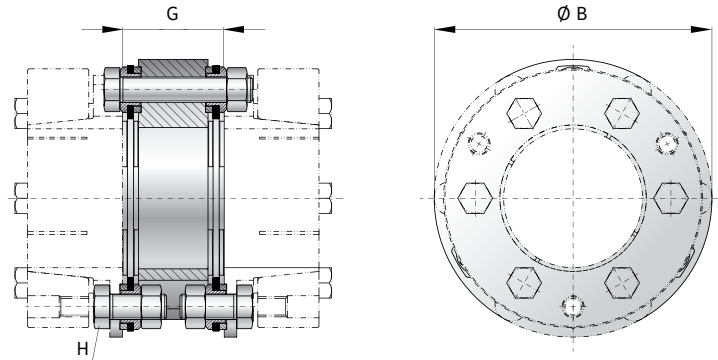

## MODEL LPZ | SIZE 500 - 12000

SIZE			500	800	2500	5000	8000	12000
Rated torque (Nm)	$T_{KN}$		500	800	2500	5000	8000	12000
Maximum torque (Nm)	$T_{Kmax}$		1000	1600	5000	10000	16000	24000
Intermediate flange length (mm)	G		32.8	37.8	62.6	80.6	90	100
Outside diameter (mm)	B		112	135	172	220	270	305
Assembly screw (ISO 4762) Nut (DIN 934)	H		M8	M10	M16	M20	M24	M24
Tightening torque (Nm)			41	83	355	690	1200	1200
Moment of inertia ( $10^{-3}kgm^2$ )	$J_{ges.}$		1	6	28	82	230	398
Material			Steel	Steel	Steel	Steel	Steel	Steel
Approximate weight (kg)			1.2	2.1	6.2	11.3	20.7	27.2
Torsional stiffness ( $10^3Nm/rad$ )	$C_T$		410	1010	1520	3200	5730	12900
Axial $\pm$ (mm)			1	1.5	2	2.5	2.5	3
Lateral $\pm$ (mm)			0.2	0.3	0.4	0.5	0.6	0.7
Angular $\pm$ (degree)			1	1	1	1	1	1
Maximum speed (1/min.)			10000	8000	6000	5000	4500	4000

Additional sizes on request

ORDERING EXAMPLE	LPZ	500	XX
Model	●		Special designation only (e.g. special material).
Size		●	
For custom features place an XX at the end of the part number and describe the special requirements (e.g. LPZ / 500 / XX)			

## TORSIONALLY STIFF DISC PACK COUPLINGS - FURTHER POSSIBILITIES

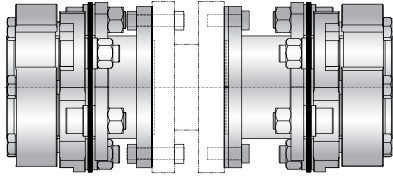

### WITH CONICAL CLAMPING RING HUBS AND FLANGE MOUNTING FOR TORQUE TRANSDUCERS

- ▶ high torsional stiffness
- ▶ high clamping pressure
- ▶ backlash free precision torque transmission

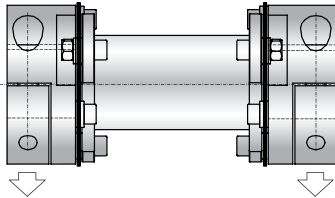

### WITH FULLY SPLIT CLAMPING HUBS

- ▶ simple lateral installation and removal
- ▶ backlash free precision torque transmission
- ▶ single or double flex

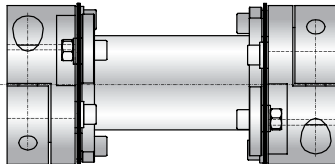

### WITH SINGLE SPLIT CLAMPING HUBS

- ▶ easy to mount
- ▶ backlash free precision torque transmission
- ▶ optional keyway
- ▶ single or double flex

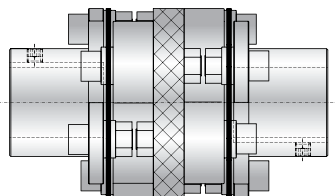

### WITH ELECTRICAL ISOLATION

- ▶ with keyed connection, conical clamping ring hub, clamping hub, or flange connection
- ▶ single flex, double flex, or rigid





# CROWNED GEAR COUPLINGS

## 1,900 – 2,080,000 Nm

### GENERAL INFORMATION ABOUT R+W CROWNED GEAR COUPLINGS:

#### FIT CLEARANCE

Overall shaft / hub clearance of 0.01 - 0.05 mm

#### TEMPERATURE RANGE

-30 to +100° C; higher temperatures on request



## CROWNED GEAR COUPLINGS

### 1,900 – 2,080,000 Nm

MODEL	FEATURES	
<p><b>BZ1</b></p>	 <p><b>with keyway mounting or cylindrical bore for interference fit from 1,900 - 2,080,000 Nm</b></p> <ul style="list-style-type: none"> <li>▶ high power density</li> <li>▶ very low backlash</li> <li>▶ economically priced</li> <li>▶ low maintenance due to special crowned tooth design</li> </ul>	<p>Page 82 - 83</p>
<p><b>BZA</b></p>	 <p><b>with keyway mounting or cylindrical bore for interference fit from 1,900 - 2,080,000 Nm</b></p> <ul style="list-style-type: none"> <li>▶ for spanning larger shaft distances</li> <li>▶ high power density</li> <li>▶ very low backlash</li> <li>▶ low maintenance due to special crowned tooth design</li> </ul>	<p>Page 84 - 85</p>
<p><b>BZ</b></p>	<p><b>Options / Special Solutions</b></p>	<p>Page 86</p>



# GENERAL INFORMATION

## CROWNED GEAR COUPLINGS

### FUNCTION OF THE GEAR COUPLING

The precise integration of the coupling hub and intermediate flange allow for low backlash and highly rigid torque transmission, while compensating for lateral, axial and

angular shaft misalignment. The crowned geometry of the gearing allows for a long life, even without the presence of misalignment.

#### Axial misalignment

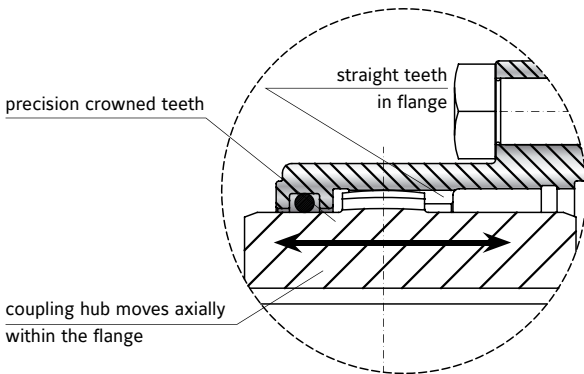

#### Angular and lateral misalignment

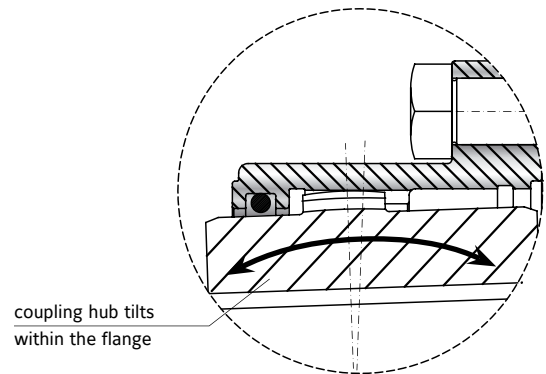

### APPROVED LUBRICANTS

► **Note:** Proper lubrication is very important to the service life of the coupling. An optional additional seal may be included in order to extend lubrication intervals.

High performance grease is recommended.

Normal speed and loads		High speed and loads	
Castrol	Impervia MDX	Caltex	Coupling Grease
Esso	Fibrax 370	Klüber	Klüberplex GE 11-680
Klüber	Klüberplex GE 11-680	Mobil	Mobilgrease XTC
Mobil	Mobilux EPO	Shell	Albida GC1
Shell	Alvania grease EP R-O or ER 1	Texaco	Coupling Grease
Total	Specis EPG		

### MAINTENANCE AND LUBRICATION

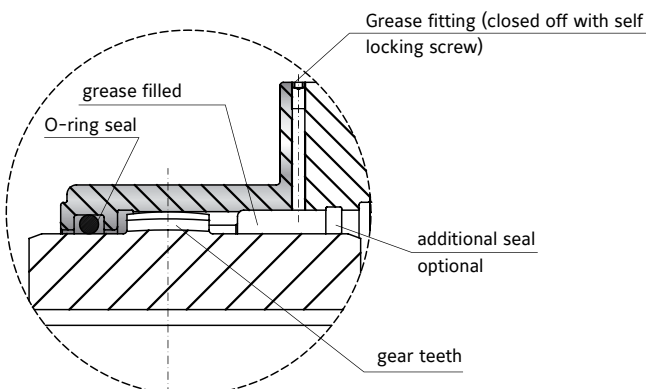

**BZ1**

# WITH KEYWAY MOUNTING

1,900 - 480,000 Nm



## PROPERTIES

### MATERIAL

Coupling from high strength steel

interference fitting.

Optional DIN 916 set screw for locking down onto shaft key.

### DESIGN

Hubs with keyway mounting or high precision cylindrical bore for

Size 450 and up with axial threads in hubs.

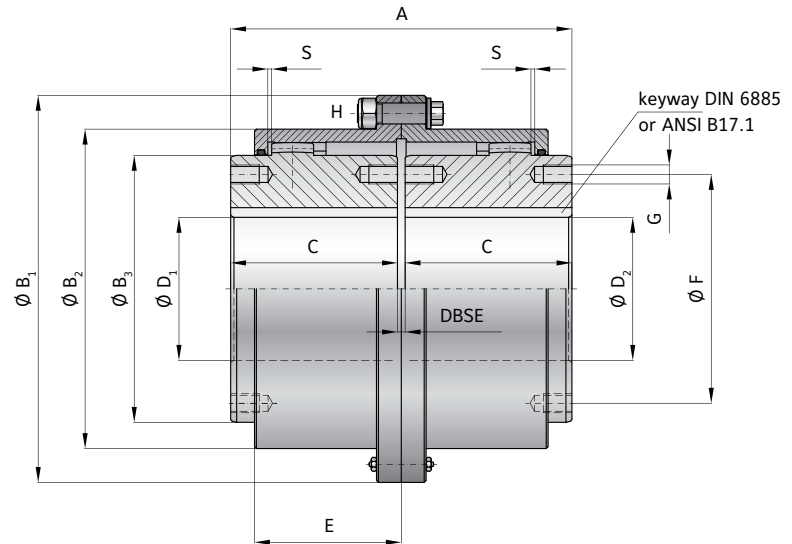

## MODEL BZ1 | SIZE 10 - 2000

SIZE			10	25	50	100	150	200	300	450	600	800	1500	2000
Rated torque (kNm)	$T_{KN}$		1.9	2.9	5.7	9	14.5	22	34	45	70	85	150	200
Max. torque (kNm)	$T_{Kmax}$		4.2	6.8	14	21.5	35	54	83	110	170	205	360	480
Installed length (mm)	A		89	103	127	157	185	216	246	278	308	358	388	450
Outside diameter (mm)	$B_1$		111	142	168	200	225	265	300	330	370	406	438	505
Flange diameter (mm)	$B_2$		82.5	104.6	130.5	158.4	183.4	211.5	245.5	275.5	307	335	367	423
Hub diameter (mm)	$B_3$		68	86	105	132	151	179	209.5	234	255	280	306	356
Hub fit length (mm)	C		43	50	62	76	90	105	120	135	150	175	190	220
Max bore diameter H7 with 1 / 2 keyways*	$D_{1/2}$		48 / 52	62 / 62	72 / 78	90 / 98	105 / 112	122 / 132	144 / 156	160 / 174	175 / 190	192 / 210	210 / 233	245 / 280
Bore diameters from $\phi$ to $\phi$ H7 with interference fit	$D_{1/2}$		12-52	18-62	30-78	32-98	42-112	45-132	50-156	60-174	70-190	90-210	110-233	120-280
Distance between shaft ends (mm)	DBSE		3	3	3	5	5	6	8	8	8	8	8	10
Hub length (mm)	E		39	46	59	78.5	92.5	108	123	139	154	179	194	225
Hole circle diameter (mm)	$\phi F$		61	73	91	115	132	154	180	204	220	240	268	316
Thread size	G		M5	M6	M8	M10	M12	M12	M16	M16	M20	M20	M24	M24
Bolt	H		M8	M10	M10	M12	M12	M16	M16	M16	M18	M22	M22	M24
Tightening torque (Nm)			18	36	36	65	65	150	150	150	220	400	400	520
Moment of inertia at Dmax ( $10^{-3} \text{kgm}^2$ )			3.9	11.6	28.7	70.6	135.3	326.7	605.6	1021	1745.5	2963	4147.2	7982
Weight at Dmax (kg)			2.5	4.8	8.4	14.2	21.4	36.0	51.5	71	99	144	165	234.5
Max speed (1/min)			6000	4550	4000	3900	3700	3550	3000	2750	2420	2270	1950	1730
Axial misalignment (mm)	S		1.5	1.5	1.5	2.5	2.5	3	4	4	4	4	4	5
Angular misalignment (Degree)			2x0.35	2x0.35	2x0.35	2x0.35	2x0.35	2x0.35	2x0.35	2x0.35	2x0.35	2x0.35	2x0.35	2x0.35

\* Larger maximum bore possible with 2 keyways, due to increased stress distribution versus wall thickness.

ORDERING EXAMPLE	BZ1	50	60	50	XX
Model	●				
Size		●			
Bore $\phi D1$ H7			●		
Bore $\phi D2$ H7				●	
Special designation only (e.g. special bore tolerance).					
For custom features place an XX at the end of the part number and describe the special requirements (e.g. BZ1 / 50 / 60 / 50 / XX)					

# BZ1

## WITH KEYWAY MOUNTING

290,000 – 2,080,000 Nm



NEW

### PROPERTIES

#### MATERIAL

Coupling from high strength steel

#### DESIGN

Hubs with keyway mounting or high precision cylindrical bore for interference fitting.  
Optional DIN 916 set screw for locking down onto shaft key.

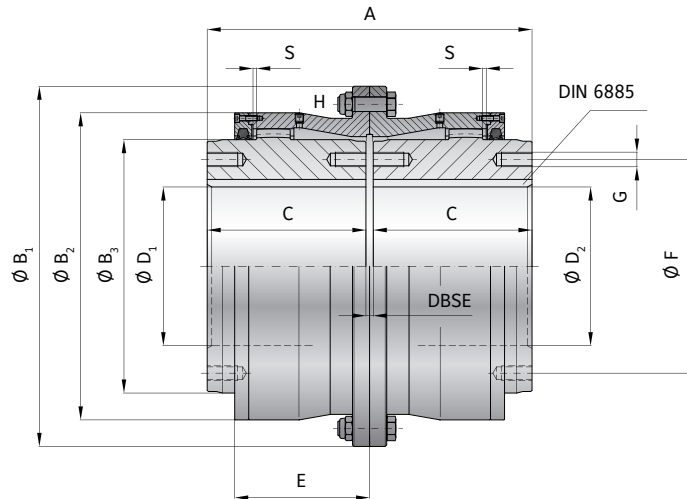

### MODEL BZ1 | SIZE 3000 - 10000

SIZE			3000	4000	5000	7000	8000	10000
Rated torque	(kNm)	$T_{KN}$	290	402	518	693	882	1040
Max. torque	(kNm)	$T_{Kmax}$	580	804	1036	1386	1764	2080
Installed length	(mm)	A	532	592	652	712	772	820
Outside diameter	(mm)	$B_1$	590	639	702	769	834	894
Flange diameter	(mm)	$B_2$	503	553	597	657	722	763
Hub diameter	(mm)	$B_3$	415	464	490	545	620	660
Hub fit length	(mm)	C	260	290	320	350	380	400
Bore diameter H7	(mm)	$D_{1/2}$	160-325	180-370	200-400	200-430	230-475	250-510
Bore diameters from $\phi$ to $\phi$ H7 with interference fit	(mm)	$D_{1/2}$	160-325	180-370	200-400	200-430	230-475	250-510
Distance between shaft ends	(mm)	DBSE	12	12	12	12	12	20
Hub length	(mm)	E	221	245.5	262	280	292	315
Hole circle diameter	(mm)	$\phi F$	350	400	430	490	560	580
Thread size		G	M24	M24	M30	M30	M24	M36
Bolt		H	M24	M24	M30	M30	M30	M36
Tightening torque	(Nm)		670	670	1250	1250	1250	2170
Moment of inertia at Dmax	( $10^{-3} \text{kgm}^2$ )		18781	28323	44986	71329	113616	150801
Weight at Dmax	(kg)		406	503	670	904	1201	1403
Max speed	(1/min)		1100	990	890	785	700	645
Axial misalignment	(mm)	S	6	6	6	6	6	10
Angular misalignment	(Degree)		2x0.35	2x0.35	2x0.35	2x0.35	2x0.35	2x0.35

CROWNED GEAR COUPLINGS BZ

ORDERING EXAMPLE	BZ1	5000	210	390	XX
Model	●				
Size		●			
Bore $\phi$ D1 H7			●		
Bore $\phi$ D2 H7				●	

Special designation only (e.g. special bore tolerance).

For custom features place an XX at the end of the part number and describe the special requirements (e.g. BZ1 / 5000 / 210 / 390 / XX)

**BZA**

# WITH KEYWAY MOUNTING

1,900 – 480,000 Nm

**NEW**

## PROPERTIES

### MATERIAL

► Coupling from high strength steel

### DESIGN

Hub with keyway connection or cylindrical bore for shrink disc.

Optional set screw for keyway DIN 916. Customer specified intermediate length also available.

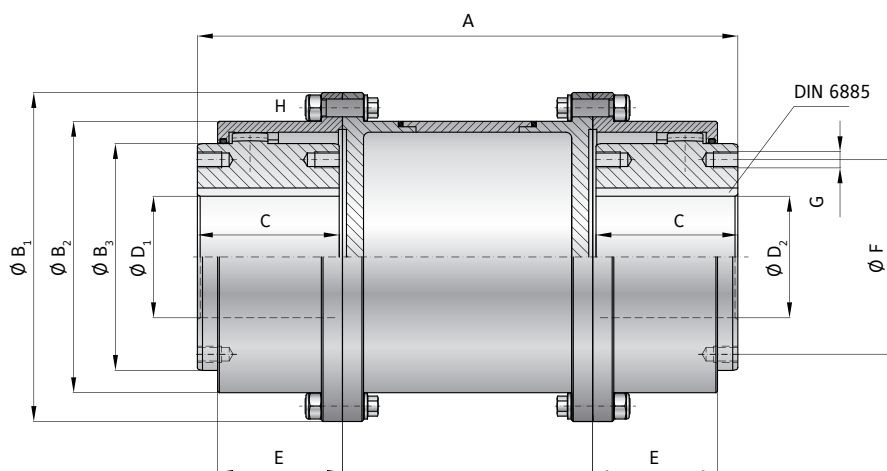

## MODEL BZA | SIZE 10 – 2000

SIZE		10	25	50	100	150	200	300	450	600	800	1500	2000
Rated torque (kNm)	$T_{KN}$	1.9	2.9	5.7	9	14.5	22	34	45	70	85	150	200
Max. torque (kNm)	$T_{Kmax}$	4.2	6.8	14	21.5	35	54	83	110	170	205	360	480
Installed length (mm)	A	89	103	127	157	185	216	246	278	308	358	388	450
Outside diameter (mm)	$B_1$	111	142	168	200	225	265	300	330	370	406	438	505
Flange diameter (mm)	$B_2$	82.5	104.6	130.5	158.4	183.4	211.5	245.5	275.5	307	335	367	423
Hub diameter (mm)	$B_3$	68	86	105	132	151	179	209.5	234	255	280	306	356
Hub fit length	C	43	50	62	76	90	105	120	135	150	175	190	220
Max bore diameter H7 with 1 / 2 keyways* (mm)	$D_{1/2}$	48 / 52	62 / 62	72 / 78	90 / 98	105 / 112	122 / 132	144 / 156	160 / 174	175 / 190	192 / 210	210 / 233	245 / 280
Bore diameters from $\phi$ to $\phi$ H7 with interference fit (mm)	$D_{1/2}$	12-52	18-62	30-78	32-98	42-112	45-132	50-156	60-174	70-190	90-210	110-233	120-280
Hub length (mm)	E	39	46	59	78.5	92.5	108	123	139	154	179	194	225
Hole circle diameter (mm)	F	61	73	91	115	132	154	180	204	220	240	268	316
Thread size	G	M5	M6	M8	M10	M12	M12	M16	M16	M20	M20	M24	M24
Bolt	H	M8	M10	M10	M12	M12	M16	M16	M16	M18	M22	M22	M24
Tightening torque (Nm)	H	18	36	36	65	65	150	150	150	220	400	400	520
Axial misalignment (mm)	S	1.5	1.5	1.5	2.5	2.5	3	4	4	4	4	4	5
Angular misalignment (Degree)		2×0.35	2×0.35	2×0.35	2×0.35	2×0.35	2×0.35	2×0.35	2×0.35	2×0.35	2×0.35	2×0.35	2×0.35

\* Larger maximum bore possible with 2 keyways, due to increased stress distribution versus wall thickness.

ORDERING EXAMPLE	BZA	50	1200	60	50	XX
Model	●					
Size		●				
Overall length mm			●			
Bore $\phi$ D1 H7				●		
Bore $\phi$ D2 H7					●	
For custom features place an XX at the end of the part number and describe the special requirements (e.g. BZA / 50 / 1200 / 60 / 50 / XX)						

Special designation only (e.g. special bore tolerance).

**BZA**

# WITH KEYWAY MOUNTING

290,000 – 2,080,000 Nm

**NEW**

## PROPERTIES

### MATERIAL

► Coupling from high strength steel

### DESIGN

Hub with keyway connection or cylindrical bore for shrink disc. Optional set screw for keyway DIN 916. Customer specified intermediate length also available.

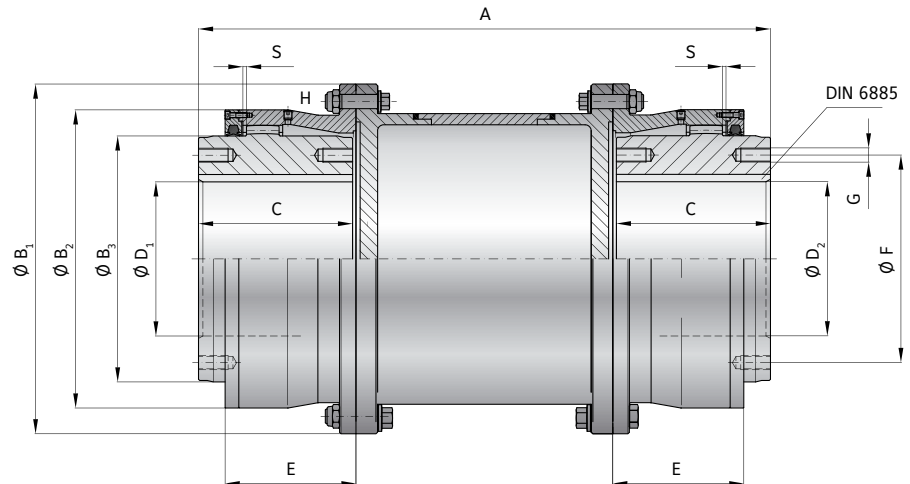

## MODEL BZA | SIZE 3000 - 10000

SIZE			3000	4000	5000	7000	8000	10000
Rated torque	(kNm)	$T_{KN}$	290	402	518	693	882	1040
Max. torque	(kNm)	$T_{Kmax}$	580	804	1036	1386	1764	2080
Installed length	(mm)	A	532	592	652	712	772	820
Outside diameter	(mm)	$B_1$	590	639	702	769	834	894
Flange diameter	(mm)	$B_2$	503	553	597	657	722	763
Hub diameter	(mm)	$B_3$	415	464	490	545	620	660
Hub fit length	(mm)	C	260	290	320	350	380	400
Bore diameter H7	(mm)	$D_{1/2}$	160-325	180-370	200-400	200-430	230-475	250-510
Bore diameters from $\phi$ to $\phi$ H7 with interference fit	(mm)	$D_{1/2}$	160-325	180-370	200-400	200-430	230-475	250-510
Hub length	(mm)	E	221	245.5	262	280	292	315
Hole circle diameter	(mm)	F	350	400	430	490	560	580
Thread		G	M24	M24	M30	M30	M24	M36
Bolt		H	M24	M24	M30	M30	M30	M36
Tightening torque	(Nm)		670	670	1250	1250	1250	2170
Axial misalignment	(mm)	S	6	6	6	6	6	10
Angular misalignment	(Degree)		2×0.35	2×0.35	2×0.35	2×0.35	2×0.35	2×0.35

CROWNED GEAR  
COUPLINGS BZ

ORDERING EXAMPLE	BZA	3000	1200	160	280	XX
Model	●					Special designation only (e.g. special bore tolerance).
Size		●				
Overall length mm			●			
Bore $\phi$ D1 H7				●		
Bore $\phi$ D2 H7					●	

For custom features place an XX at the end of the part number and describe the special requirements (e.g. BZA / 3000 / 1200 / 160 / 280 / XX)

## FLEXIBLE GEAR COUPLINGS - FURTHER POSSIBILITIES

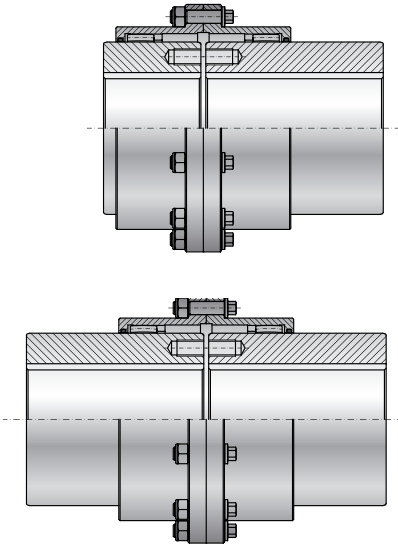

## WITH EXTENDED HUB ON ONE OR BOTH ENDS

- ▶ Hub length is customizable
- ▶ Easy replacement of existing gear couplings
- ▶ Optimal utilization of available space

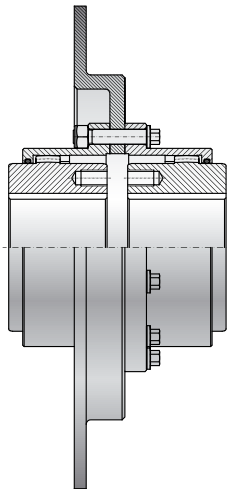

## WITH BRAKE DISC

- ▶ custom dimensions available
- ▶ use for holding or emergency stopping

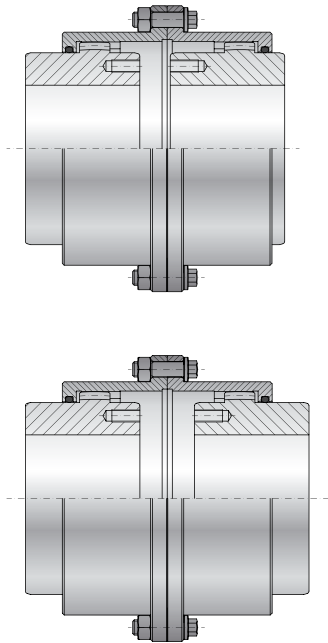

## WITH REVERSED HUB ON ONE OR BOTH ENDS

- ▶ for minor increases in the distance between shaft ends
- ▶ optimized torque transfer with best shaft engagement
- ▶ longer life

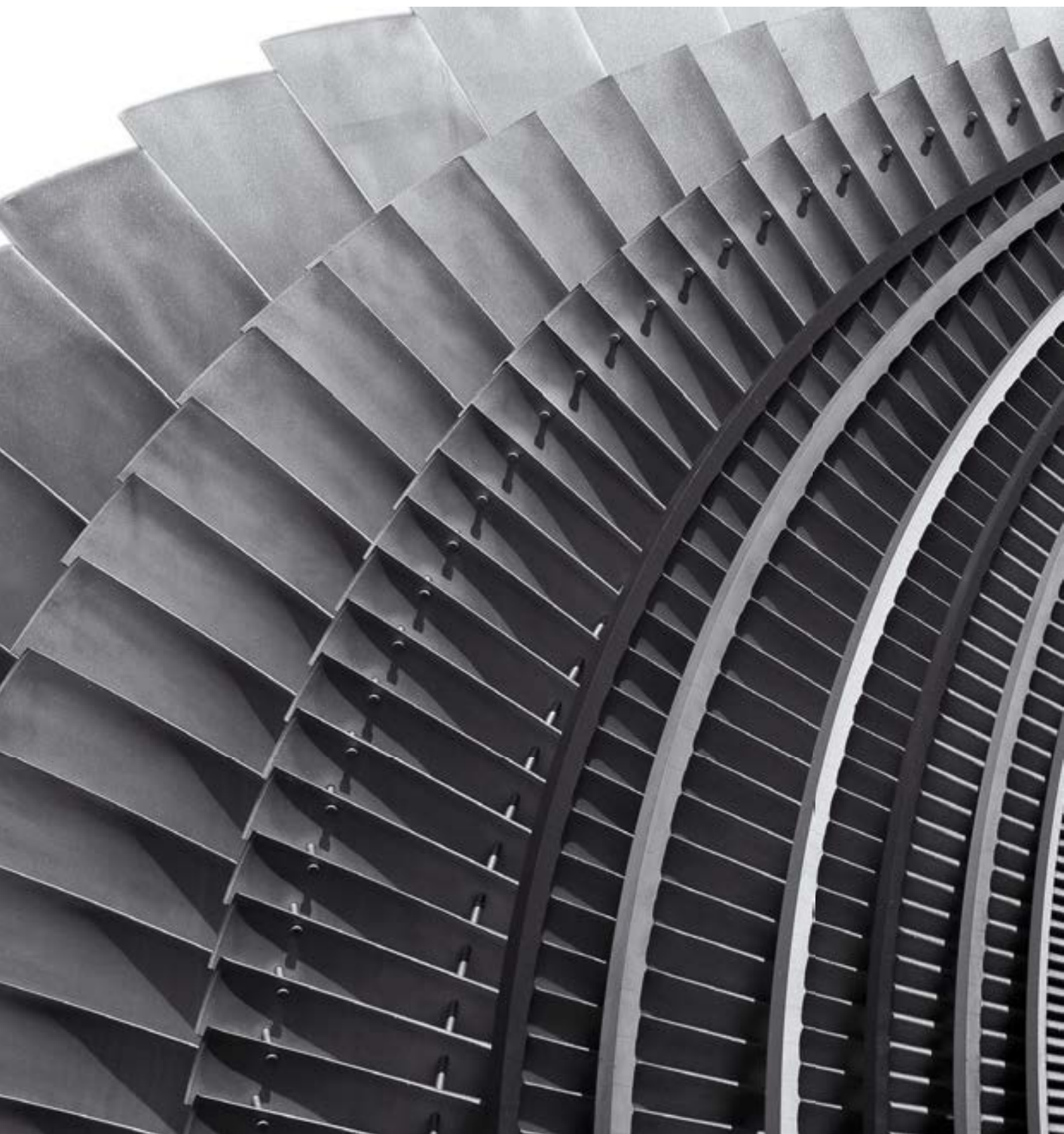





# BACKLASH FREE, TORSIONALLY STIFF METALLIC BELLOWS COUPLINGS 10,000- 100,000 Nm



## GENERAL INFORMATION ABOUT R+W BELLOWS COUPLINGS:



### SERVICE LIFE

R+W bellows couplings are fatigue resistant and wear free for an infinite service life, as long as the technical limits are not exceeded.

### FIT CLEARANCE

Overall shaft / hub clearance of 0.03 - 0.08 mm

### TEMPERATURE RANGE

-40 to +300° C

### SPECIAL SOLUTIONS

Various materials, tolerances, dimensions and performance ratings available for custom applications on request.

### ATEX (Optional)

For use in hazardous areas available upon request.



# TORSIONALLY STIFF METALLIC BELLOWS COUPLINGS

## 10,000 – 100,000 Nm

MODEL

FEATURES

<b>BX1</b>		<b>with flange mounting</b> from 10,000 - 100,000 Nm ▶ for customer specific applications	Page 91
<b>BX4</b>		<b>with simple keyway mounting</b> from 10,000 - 100,000 Nm ▶ low backlash keyway connection ▶ compact, simple design	Page 92
<b>BX6</b>		<b>with conical clamping ring</b> from 10,000 - 100,000 Nm ▶ backlash free conical clamping ▶ high shaft clamping pressure	Page 93

**BX1**

# WITH FLANGE MOUNTING

10,000 - 100,000 Nm



## PROPERTIES

### FEATURES

- ▶ compact, simple design
- ▶ high misalignment compensation
- ▶ integral support system (size 25 and up)

### MATERIAL

- ▶ **Hubs:** steel
- ▶ **Bellows:** highly flexible high grade stainless steel

### DESIGN

Both ends with flanged hubs  
 Spacer between bellows  
 (optional variable length)  
 (size 10 without spacer)  
 welded bellows-hub connection

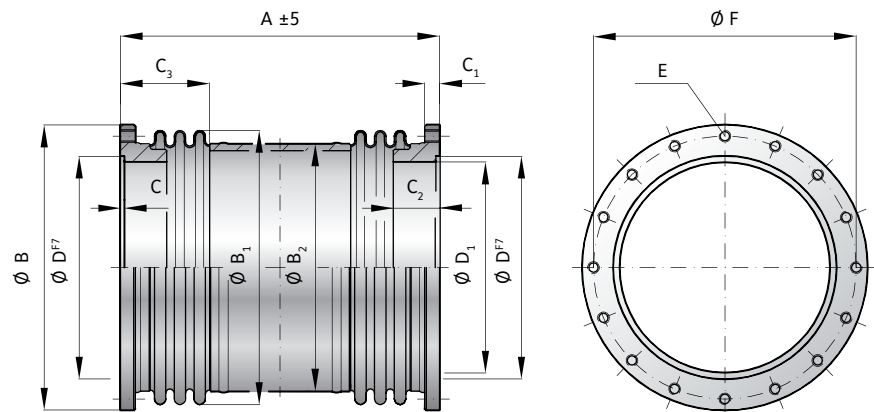

## MODEL BX1 | SIZE 10 - 100

SIZE			10	25	50	75	100
Rated torque	(KNm)	$T_{KN}$	10	25	50	75	100
Maximum torque	(KNm)	$T_{Kmax}$	15	38	75	113	150
Overall length	(mm)	$A \pm 5$	125	380	450	580	640
Outside diameter of flange	(mm)	B	310	336	398	449	545
Outside diameter of bellows $\pm 2$	(mm)	$B_1$	300	323	370	412w	520
Outside diameter of tube	(mm)	$B_2$	-	273	324	360	460
Fit length $+0.5$	(mm)	$C^{+0.5}$	4	5	6	10	15
Thread depth	(mm)	$C_1$	15	25	30	36	36
Hub length	(mm)	$C_2$	24	81	80	103	120
Bellows body length $+3$	(mm)	$C_3$	-	121	133	165	165
Centering diameter F 7	(mm)	D	265	260	310	350	440
Hub diameter $+0.3$	(mm)	$D_1$	250	240	285	317	390
Fastening threads*			20x M12	24x M16	24x M20	20x M24	24x M24
Tightening torque of the fastening screws (screw grade 10.9)	(Nm)	E	120	300	580	1000	1000
Bolt circle diameter $\pm 0.4$	(mm)	F	290	304	361	404	500
Moment of inertia	( $10^{-3} \text{ kgm}^2$ )	$J_{ges.}$	101	548	1185	2725	7900
Approximate weight	(kg)		8.3	27.8	43.7	80	151
Axial	$\pm$ (mm)	Max. value	3	5	6	7	8
Lateral	$\pm$ (mm)		0.4	2.2	2.5	3	3.5
Angular	$\pm$ (degree)		1.5	1	1	1	1
Torsional stiffness coupling	( $10^3 \text{ Nm/rad}$ )		20,000	9,000	15,500	23,000	35,000
Axial spring stiffness bellows	(N/mm)		985	3000	4300	3900	2800
Lateral spring stiffness bellows	(KN/mm)		21	133	207	175	219

\*drilling pattern between hub 1 and hub 2 not aligned as standard

ORDERING EXAMPLE	BX1	50	XX
Model	●		Special designation only (e.g. stainless steel hubs)
Size / torque rating (KNm)		●	

For custom features place an XX at the end of the part number and describe the special requirements (e.g. BX1 / 50 / XX)

# BX4

## WITH SIMPLE KEYWAY MOUNTING

10,000 – 100,000 Nm



### PROPERTIES

#### FEATURES

- ▶ compact, simple design
- ▶ high misalignment compensation
- ▶ integral support system (size 25 and up)

#### MATERIAL

- ▶ **Hubs:** steel
- ▶ **Bellows:** highly flexible high grade stainless steel

#### DESIGN

Both sides with removable coupling hubs, including keyway (splines optional)  
 Spacer between bellows (optional variable length) (size 10 without spacer)  
 welded bellows-hub connection

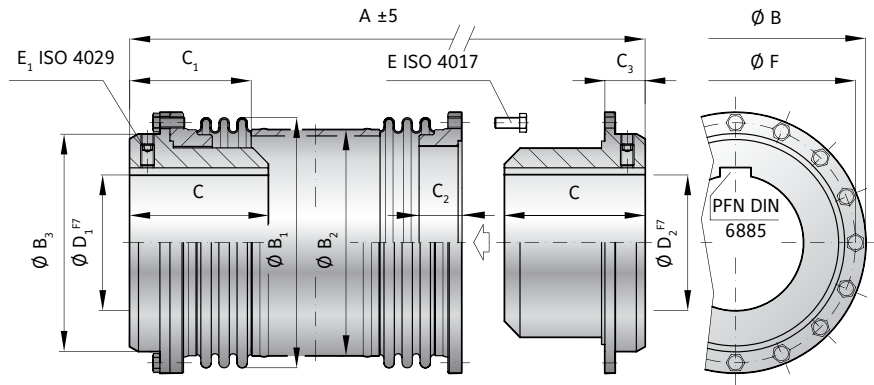

## MODEL BX4 | SIZE 10 - 100

SIZE			10	25	50	75	100
Rated torque (KNm)	$T_{KN}$		10	25	50	75	100
Maximum torque (KNm)	$T_{Kmax}$		15	38	75	113	150
Overall length (mm)	$A_{\pm 5}$		210	480	590	760	840
Outside diameter of flange (mm)	B		310	336	398	449	545
Outside diameter of bellows $\pm 2$ (mm)	$B_1$		300	323	370	412	520
Outside diameter of tube (mm)	$B_2$		-	273	324	360	460
Hub diameter (mm)	$B_3$		255	260	310	350	440
Fit length (mm)	C		95	130	200	240	280
Length $\pm 3$ (mm)	$C_1$		-	170	200	257	260
Hub length (mm)	$C_2$		24	81	80	103	120
Distance (mm)	$C_3$		42	49	70	90	100
Inside diameter possible from $\emptyset$ to $\emptyset$ F7 (mm)	$D_1/D_2$		50 - 170	60 - 170	80 - 200	100 - 230	120 - 280
Fastening screw ISO 4017 / Tightening torque (Nm)	E		20 x M12 / 120	24 x M16 / 300	24 x M20 / 580	20 x M24 / 1000	24 x M24 / 1000
Fastening screw ISO 4029 / Tightening torque (Nm)	$E_1$		M12 / 100	M16 / 220	M20 / 450	M24 / 800	M24 / 800
Bolt circle diameter $\pm 0.4$ (mm)	F		290	304	361	404	500
Moment of inertia ( $10^{-3}$ kgm <sup>2</sup> )	$J_{ges}$		492	1272	3270	6754	19350
Approximate weight (kg)			44.7	85	164	260	477
Axial $\pm$ (mm)		Max. value	3	5	6	7	8
Lateral $\pm$ (mm)	0.4		2.2	2.5	3	3.5	
Angular $\pm$ (degree)	1.5		1	1	1	1	
Torsional stiffness coupling ( $10^3$ Nm/rad)			20,000	9,000	15,500	23,000	35,000

## MAXIMUM TRANSMITTABLE TORQUE OF KEYWAY CONNECTION

Data is in KNm. These values relate to metric DIN 6885 keyway dimensions with 100% contact through the hub.

Serie	Ø 60	Ø 80	Ø 100	Ø 120	Ø 140	Ø 160	Ø 170	Ø 180	Ø 200	Ø 220	Ø 230	Ø 240	Ø 260	Ø 280
10	x	x	x	x	x	x	x	x	x	x	x	x	x	x
25	7	12	18	26	34	44	46	x	x	x	x	x	x	x
50	x	19	28	40	52	67	71	84	94	x	x	x	x	x
75	x	x	34	47	62	81	85	101	112	136	142	x	x	x
100	x	x	x	55	74	94	100	118	131	159	166	189	205	220

# BX6

## WITH REMOVABLE CONICAL CLAMPING RING HUB 10,000 - 100,000 Nm



### PROPERTIES

#### FEATURES

- ▶ compact, simple design
- ▶ high misalignment compensation
- ▶ integral support (size 25 and up)

#### MATERIAL

- ▶ **Hubs:** steel
- ▶ **Bellows:** highly flexible high grade stainless steel

#### DESIGN

Both sides with removable clamping hubs including conical clamping ring system.

Spacer between bellows (optional variable length) (size 10 without spacer)

welded bellows-hub connection

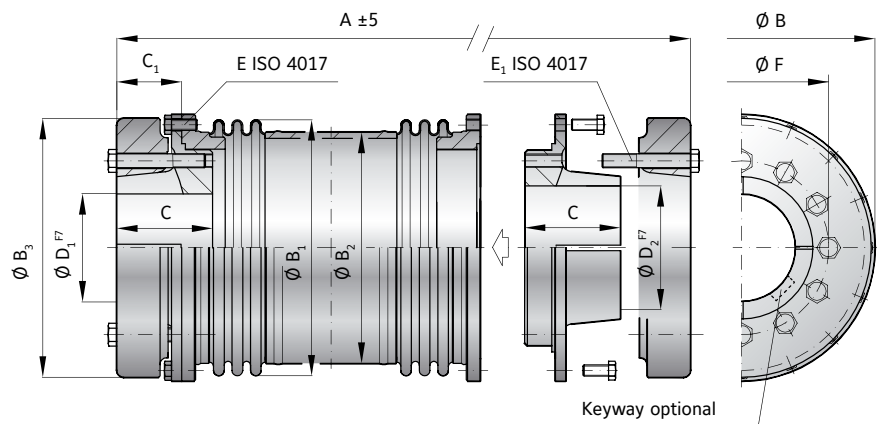

### MODEL BX6 | SIZE 10 - 100

SIZE			10	25	50	75	100
Rated torque (KNm)	$T_{KN}$		10	25	50	75	100
Maximum torque (KNm)	$T_{Kmax}$		15	38	75	113	150
Overall length (mm)	$A_{\pm 5}$		235	530	650	840	940
Outside diameter of flange (mm)	B		310	336	398	449	545
Outside diameter of bellows $\pm 2$ (mm)	$B_1$		300	323	370	412	520
Outside diameter of tube (mm)	$B_2$		-	273	324	360	460
Diameter of clamping ring (mm)	$B_3$		300	310	380	420	530
Fit length (mm)	C		90	110	140	170	200
Length (mm)	$C_1$		55	74	99	130	150
Inside diameter possible from $\emptyset$ to $\emptyset$ F7 (mm)	$D_1/D_2$		70 - 170	80 - 170	100 - 200	130 - 230	150 - 280
Fastening screw ISO 4017 for mounting flange (mm)	E		20 x M12	24 x M16	24 x M20	20 x M24	24 x M24
Tightening torque (Nm)			120	300	580	1000	1000
Fastening screw ISO 4017 for conical clamping ring (mm)	$E_1$		8 x M16	12 x M16	12 x M20	16 x M20	12 x M24
Tightening torque (Nm)			200	250	300	350	600
Bolt circle diameter $\pm 0.4$ (mm)	F		210	220	250	290	360
Moment of inertia ( $10^{-3}$ kgm <sup>2</sup> )	$J_{ges}$		828	1535	3799	8277	24876
Approximate weight (kg)			60	93	168	280	550
Axial $\pm$ (mm)		Max. value	3	5	6	7	8
Lateral $\pm$ (mm)			0.4	2.2	2.5	3	3.5
Angular $\pm$ (degree)			1.5	1	1	1	1
Torsional stiffness coupling ( $10^3$ Nm/rad)			20,000	9,000	15,500	23,000	35,000

ORDERING EXAMPLE	BX4   BX6	50	120	200	XX
Model	●				
Size / torque rating (KNm)		●			
Bore D1 F7			●		
Bore D2 F7				●	
Special designation only (e.g. stainless steel hubs)					
For custom features place an XX at the end of the part number and describe the special requirements (e.g. BX4 / 50 / 117.48 / 127 / XX; XX = 700 mm overall length)					

BELLOWS COUPLING  
BX





**EK****EZ**

# BACKLASH FREE SERVOMAX® ELASTIC JAW COUPLINGS 1,950 – 25,000 Nm



## GENERAL INFORMATION ABOUT R+W ELASTOMER COUPLINGS:



### SERVICE LIFE

When properly selected, handled, and installed, these couplings are maintenance free with infinite service life.

### ATEX (Optional)

For use in hazardous areas available upon request.

### SPECIAL SOLUTIONS

Various materials, tolerances, dimensions and performance ratings available for custom applications on request.

### FIT CLEARANCE

Overall shaft / hub clearance of 0.01 - 0.05 mm

**EK****EZ**

## BACKLASH FREE SERVOMAX® ELASTIC JAW COUPLINGS 1,950 – 25,000 Nm

MODEL		FEATURES	
<b>EK1</b>		<b>with simple keyway mounting from 1,950 - 25,000 Nm</b> <ul style="list-style-type: none"><li>▶ economically priced version</li><li>▶ modifiable to customer specific dimensions and features</li></ul>	Page 98
<b>EKH</b>		<b>with fully split clamping hubs from 1,950 - 25,000 Nm</b> <ul style="list-style-type: none"><li>▶ easy installation and removal</li><li>▶ allows for lateral mounting</li></ul>	Page 99
<b>EK6</b>		<b>with conical clamping ring from 1,950 - 25,000 Nm</b> <ul style="list-style-type: none"><li>▶ highly concentric design</li><li>▶ high clamping pressure on shafts</li><li>▶ hubs mount axially</li><li>▶ in case a housing will be used, no access holes are necessary</li></ul>	Page 100
<b>EZ2</b>		<b>with fully split clamping hubs from 1,950 - 25,000 Nm</b> <ul style="list-style-type: none"><li>▶ standard lengths of up to 4 meters</li><li>▶ no intermediate support bearing necessary</li><li>▶ lateral installation and removal without disturbing adjacent equipment</li></ul>	Page 101



# GENERAL INFORMATION

## R+W ELASTIC JAW COUPLINGS

### SHAFT MISALIGNMENT

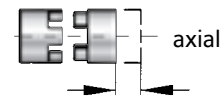
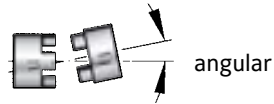
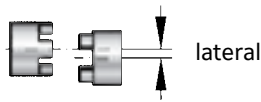

### FUNCTION

The equalizing element of the EK coupling is the elastomer insert. It transmits torque without backlash or vibration. The elastomer insert defines the characteristics of the entire drive system.

Backlash is eliminated by the press fit of the elastomer into the hubs. Through variation of the Shore hardness of the elastomer insert, the coupling system can be optimized for the ideal torsional characteristics.

### SIZE 2500 - 9500

THE COUPLING INCLUDES 5X ELASTOMER SEGMENTS

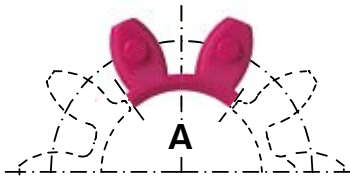

Shore hardness 98 Sh A

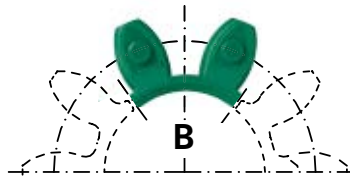

Shore hardness 64 Sh D

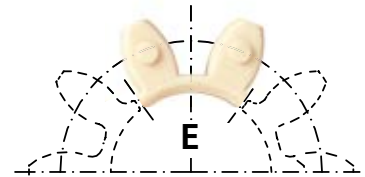

Shore hardness 64 Sh D

### DESCRIPTION OF THE ELASTOMER TYPES

Type	Shore hardness	Color	Material	Relative damping ( $\Psi$ )	Temperature range	Features
A	98 Sh A	red	TPU	0.4 - 0.5	-30°C to +100°C	high damping
B	64 Sh D	green	TPU	0.3 - 0.45	-30°C to +120°C	high torsional stiffness
E	64 Sh D	beige	Hytrel	0.3 - 0.45	-50°C to +150°C	temperature resistant

The values of relative damping were determined at 10 Hz and +20° C.

### SIZES EK

SIZE		2500		4500		9500	
Type (elastomer insert)		A	B	A	B	A	B
Static torsional stiffness (Nm/rad)	$C_T$	87600	109000	167000	372000	590000	670000
Dynamic torsional stiffness (Nm/rad)	$C_{Tdyn}$	175000	216000	337000	743000	1180000	1340000
lateral misalignment (mm)	Max. values	0.5	0.3	0.5	0.3	0.6	0.4
angular misalignment (Degree)		1.5	1	1.5	1	1.5	1
axial misalignment (mm)		±3		±4		±5	

Static torsional stiffness at 50%  $T_{KN}$

Dynamic torsional stiffness at  $T_{KN}$

**EK1**

# WITH KEYWAY MOUNTING

1,950 - 25,000 Nm



## PROPERTIES

### FEATURES

- ▶ press fit design
- ▶ readily modified for custom dimensions
- ▶ low backlash (keyway)

### MATERIAL

- ▶ **Hubs:** GGG40
- ▶ **Elastomer:** wear resistant thermally stable TPU

### DESIGN

Two concentrically machined hubs with curved jaws, keyways, and set screws. 5x elastomer segments press fit for zero backlash; standard versions are electrically isolating.

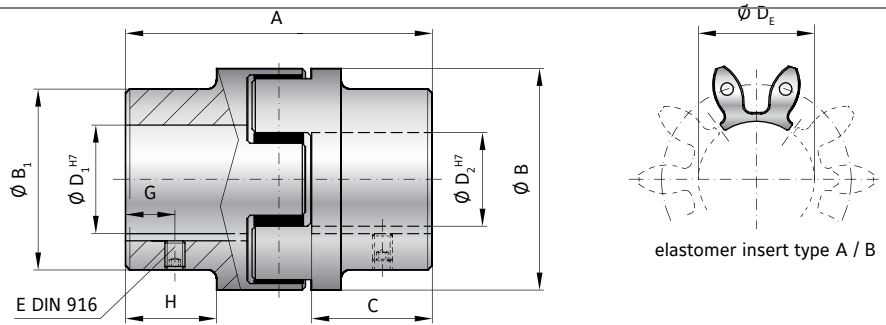

## MODEL EK1 | SIZE 2500 - 9500

SIZE		2500		4500		9500	
Type (Elastomer insert)		A	B	A	B	A	B
Rated torque (Nm)	$T_{KN}$	1950	2450	5000	6200	10000	12500
Max. torque (Nm)	$T_{Kmax}$	3900	4900	10000	12400	20000	25000
Overall length (mm)	A	213		272		341	
Outside diameter (mm)	B/B <sub>1</sub>	160 / 154		225 / 190		290 / 240	
Mounting length (mm)	C	88		113		142	
Inside diameter (pilot bored) (mm)	D <sub>v</sub>	30		40		50	
Inside diameter range H7 (mm)	D <sub>1/2</sub>	30 - 95		40 - 130		50 - 170	
Inside diameter of elastomer (mm)	D <sub>e</sub>	80		111		145	
Set screws (DIN 916)	E	see table (depending on bore $\phi$ )**					
Distance (mm)	G	25		30		40	
Possible shortening length (mm)	H	69		89		110	
Moment of inertia per hub (10 <sup>-3</sup> kgm <sup>2</sup> )	J <sub>1</sub> /J <sub>2</sub>	40		147		480	
Approx. weight (kg)		12,5		25		53	
Speed standard (min <sup>-1</sup> )		3,500		3,000		2,000	
Speed balanced (10 <sup>3</sup> min <sup>-1</sup> )		10	10	8	8	6,5	6,5

For information on shaft misalignment, torsional stiffness, and other details about the elastomer inserts see page 97.

** Set screw	ORDERING EXAMPLE	EK1	2500	A	50.8	80	XX
$\phi$ 12.1 - 30 M5	Model	●					Special designation only (e.g. special bore tolerance).
$\phi$ 30.1 - 58 M8	Size		●				
$\phi$ 58.1 - 95 M10	Elastomer insert type			●			
$\phi$ 95.1 - 130 M12	Bore D1 H7				●		
$\phi$ 130.1 - 170 M16	Bore D2 H7					●	
For custom features place an XX at the end of the part number and describe the special requirements (e.g. EK1 / 2500 / A / 50.8 / 80 / XX; XX = stainless steel)							



#### PROPERTIES

##### FEATURES

- ▶ lateral mounting
- ▶ easy installation and removal
- ▶ allows for pre-alignment of shafts

##### MATERIAL

- ▶ **Hubs:** GGG40
- ▶ **Elastomer:** wear resistant thermally stable TPU

##### DESIGN

Two concentrically machined, fully split hubs with curved jaws and clamping screws. 5x elastomer segments press fit for zero backlash; standard versions are electrically isolating.

ORDERING EXAMPLE  
see page 98

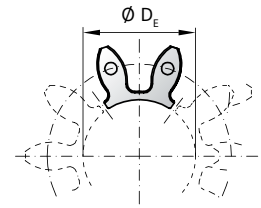
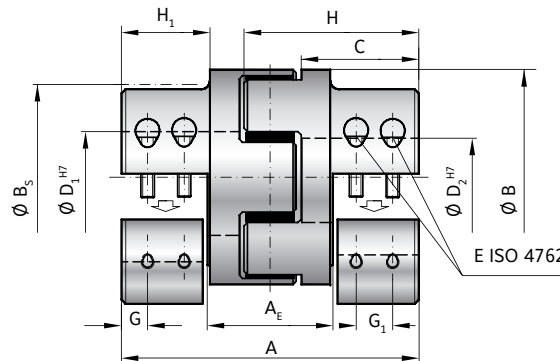

elastomer insert type A / B

## MODEL EKH | SIZE 2500 - 9500

SIZE			2500		4500		9500	
Type (Elastomer insert)			A	B	A	B	A	B
Rated torque (Nm)	$T_{KN}$		1950	2450	5000	6200	10000	12500
Max. torque* (Nm)	$T_{Kmax}$		3900	4900	10000	12400	20000	25000
Overall length (mm)	A		213		272		341	
Length of center section (mm)	$A_E$		78		104		131	
Outside diameter (mm)	B		160		225		290	
Outside diameter with screw head (mm)	$B_5$		156		199		243	
Mounting length (mm)	C		85		113		140	
Inside diameter range H7 (mm)	$D_{1/2}$		35 - 90		40 - 120		50 - 140	
Inside diameter of elastomer (mm)	$D_E$		80		111		145	
Clamping screw (ISO 4762)			8 × M16		8 × M20		8 × M24	
Tightening torque of the clamping screw (Nm)	E		300		600		1100	
Distance between centers (mm)	F		57		75		90	
Distance (mm)	G/ $G_1$		36		24 / 41		30 / 48	
Hub length (mm)	H/ $H_1$		120 / 69		154 / 89		193 / 110	
Moment of inertia per hub ( $10^{-3} \text{ kgm}^2$ )	$J_1/J_2$		40		147		480	
Approx. weight (kg)			12.5		25		53	
Speed standard ( $\text{min}^{-1}$ )			3,000		3,500		2,000	
Speed balanced ( $10^2 \text{ min}^{-1}$ )			10	10	8	8	6.5	6.5

For information on shaft misalignment, torsional stiffness, and other details about the elastomer inserts see page 97.

\*\* Maximum transmittable torque of the clamping hub depends on the bore diameter

Size	Ø 35	Ø 45	Ø 50	Ø 55	Ø 60	Ø 65	Ø 70	Ø 75	Ø 80	Ø 90	Ø 120	Ø 140
2500	1400	1800	2000	2250	2500	2700	2900	3100	3300	3700		
4500		2400	2600	2900	3100	3400	3600	3900	4100	4700	6200	
9500			5000	5500	6000	6500	7000	7500	8000	9000	12000	14000

Higher torques possible with keyway.

# EK6

## WITH CONICAL CLAMPING RING

1,950 - 25,000 Nm



### PROPERTIES

#### FEATURES

- ▶ high clamping pressure
- ▶ self centering on shaft
- ▶ very high concentricity

#### MATERIAL

- ▶ **Hubs:** GGG40
- ▶ **Elastomer:** wear resistant thermally stable TPU

#### DESIGN

Two concentrically machined hubs with curved jaws and conical clamping rings. 5x elastomer segments press fit for zero backlash; standard versions are electrically isolating.

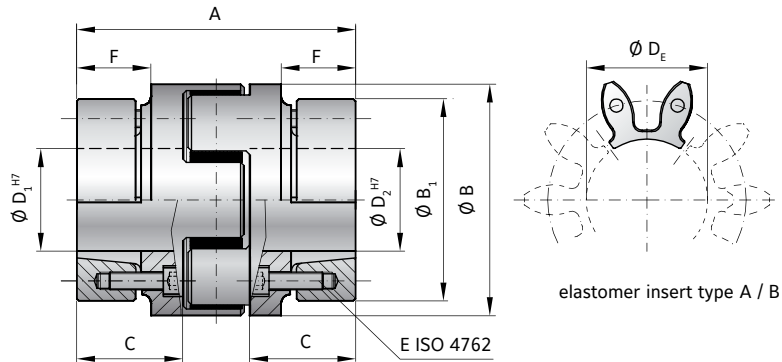

## MODEL EK6 | SIZE 2500 - 9500

SIZE		2500		4500		9500	
Type (Elastomer insert)		A	B	A	B	A	B
Rated torque (Nm)	$T_{KN}$	1950	2450	5000	6200	10000	12500
Max. torque (Nm)	$T_{Kmax}$	3900	4900	10000	12400	20000	25000
Overall length (mm)	A	177		227		282	
Outside diameter (mm)	$B/B_1$	160 / 159		225 / 208		285	
Mounting length (mm)	C	70		90		112	
Inside diameter range H7 (mm)	$D_{1/2}$	40 - 95		50 - 130		60 - 170	
Inside diameter of elastomer (mm)	$D_E$	80		111		145	
Clamping screw (ISO 4762)		10x M10		10x M12		10x M16	
Tightening torque of the clamping screw (Nm)	E	60		100		160	
Distance (mm)	F	51		66		80	
Moment of inertia per hub ( $10^{-3} \text{ kgm}^2$ )	$J_1/J_2$	31.7		135.7		469.2	
Approx. weight (kg)		15		35		73	
Speed standard ( $\text{min}^{-1}$ )		3,500		3,000		2,000	
Speed balanced ( $10^3 \text{ min}^{-1}$ )		10	10	8	8	6.5	6.5

For information on shaft misalignment, torsional stiffness, and other details about the elastomer inserts see page 97.

ORDERING EXAMPLE	EK6 / EKH	2500	A	50.8	80	XX
Model	●					Special designation only (e.g. special bore tolerance).
Size		●				
Elastomer insert type			●			
Bore D1 H7				●		
Bore D2 H7					●	

For custom features place an XX at the end of the part number and describe the special requirements (e.g. EK6 / 2500 / A / 50.8 / 80 / XX; XX = stainless steel)

# EZ2

## WITH FULLY SPLIT CLAMPING HUB

1,950 - 25,000 Nm



### PROPERTIES

#### FEATURES

- ▶ easy installation and removal
- ▶ standard lengths up to 4 meters
- ▶ no intermediate support bearings required

#### MATERIAL

- ▶ **Hubs:** GGG40
- ▶ **Intermediate tube:** steel, optional CFK tube on request
- ▶ **Elastomer insert:** wear resistant, thermally stable TPU

#### DESIGN

Two fully split clamping hubs with concave driving jaws and four clamping screws. Both coupling bodies are firmly connected to a highly straight and laterally stiff intermediate tube. Elastomer consists of five separate segments. The elastomer insert makes the coupling axially mountable, backlash free, and electrically isolating.

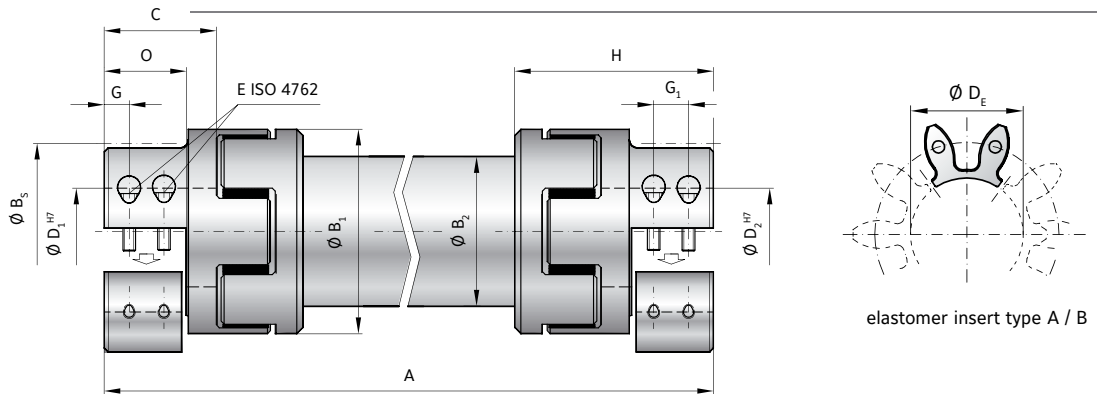

### MODEL EZ2 | SIZE 2500 - 9500

SIZE	2500		4500		9500		
	A	B	A	B	A	B	
Type (Elastomer insert)							
Rated torque (Nm)	T <sub>KN</sub>	1950	2450	5000	6200	10000	12500
Maximum torque* (Nm)	T <sub>Kmax</sub>	3900	4900	10000	12400	20000	25000
Overall length (mm)	A	460 - 4000		580 - 4000		710 - 4000	
Outer diameter hub (mm)	B <sub>1</sub>	160		225		290	
Outer diameter tube (mm)	B <sub>2</sub>	150		175		220	
Outer diameter with screwhead (mm)	B <sub>3</sub>	155		199		243	
Fit length (mm)	C	88		110		140	
Inside diameter range from Ø to Ø H7 (mm)	D <sub>1/2</sub>	35 - 90		40 - 120		50 - 140	
Max. inside diameter (Elastomer insert) (mm)	D <sub>E</sub>	80		111		145	
Mounting screw ISO 4762	E	4 x M16		8 x M20		8 x M24	
Tightening torque (Nm)		300		600		980	
Distance between centers (mm)	F	57		75		90	
Distance (mm)	G/G <sub>1</sub>	18 / 30		24 / 41		30 / 48	
Hub length (mm)	H	142		181		229	
Moment of inertia per hub (10 <sup>-3</sup> kgm <sup>2</sup> )	J <sub>1</sub> /J <sub>2</sub>	30		140		450	
Inertia of tube per meter (10 <sup>-3</sup> kgm <sup>2</sup> )	J <sub>3</sub>	360		750		1.800	
Combined dynamic torsional stiffness of the inserts (Nm/rad)	C <sub>Tdyn</sub> <sup>E</sup>	87,500	108,000	168,500	371,500	590,000	670,000
Torsional stiffness of tube per meter (Nm/rad)	C <sub>T</sub> <sup>ZWR</sup>	950,000		2,200,200		5,500,000	
Shaft average value (mm)	N	108		137		171	
Length (mm)	O	67		85		105	

\* Maximum transmittable torque of the clamping hub depends on the bore diameter - see page 99.

ORDERING EXAMPLE	EZ2	2500	1200	A	50.8	80	XX
Model	●						Special designation only (e.g. special bore tolerance).
Size		●					
Overall length			●				
Elastomer insert type				●			
Bore Ø D1 H7					●		
Bore Ø D2 H7						●	
For custom features place an XX at the end of the part number and describe the special requirements (e.g. EZ2 / 2500 / 1200 / A / 50.8 / 80 / XX; XX = stainless steel)							



**ATEX**

**FOR USE IN  
HAZARDOUS AREAS**





# FOR USE IN HAZARDOUS AREAS INDUSTRIAL DRIVE COUPLINGS

## MARKING EXAMPLE

Based on the ATEX markings the product can be certified for suitability under certain conditions.

	II	2G	c	IIA T6	X
	II	2D	c	85°C	X
	Equipment group	Category	Protection type	Explosion group / temperature class / maximum surface temperature	Additional features

Equipment group	Approval type
I	approved for underground operation
II	approved for all other applications

Category	Approved for zone	Zone description
1G	0	Area in which an explosive atmosphere consisting of a mixture of air and flammable gases, vapors, or mists, is present continuously, frequently, or for long periods of time.
2G	1	Area in which the potential exists for an explosive mixture of air and flammable gases, vapors, or mists to occur.
3G	2	Area in which the potential for an explosive mixture of air and flammable gases, vapors, or mists to occur is unlikely and only for a brief duration.
1D	20	Area with the same conditions as zone 0, with powder or dust.
2D	21	Area with the same conditions as zone 1, with powder or dust.
3D	22	Area with the same conditions as zone 2, with powder or dust.

Protection type	Definition
c	Design safety level: ignition hazard is avoided by the product design.

### Example classification by occurring gases, mists and vapors according to temperature class and explosion group

Explosion group / temperature class / maximum surface temperature	IIA	IIB (includes IIA)	IIC (includes IIA + IIB)
T1 / 450°C	acetone, ammonia, methane...	natural gas	hydrogen
T2 / 300°C	ethyl alcohol, butane, cyclohexane...	ethylene, ethylene oxide	ethyne (acetylene)
T3 / 200°C	gasoline, diesel fuel, fuel oil...	ethylene glycol, hydrogen sulfide	
T4 / 135°C	acetaldehyde	ethyl ether	
T5 / 100°C			
T6 / 85°C			carbon disulphide

Additional labeling	Definition
X	Special operating conditions
U	Product is only a component in a machine. Conformity therefore shall only be declared after installation.



## GENERAL INFORMATION

---

The use of devices and components in explosive areas is governed by the European directives 94/9/EC (for manufacturers) and 1992/92/EC (for operators). The presented products are non-electrical equipment of category 2.

According to Directive 94/9/EC, delivery of an ATEX coupling requires the inclusion of special installation and operating instructions along with the EC declaration of conformity issued by the manufacturer. All necessary values for installation, operation and removal are included.

All models of BX, LP, EK, and ST are available with ATEX certification on request. The BZ coupling is not intended for use in hazardous areas.

R+W Couplings are ATEX approved for use in general industry (Group II). Operation in hazardous zones 1 and 2 (Category 2G) and 21 and 22 (category 2D) are allowed. For the device group I, as well as for zones 0 and 20 the couplings are not registered.

Product specific information about ATEX certified couplings, such as temperature class, are available on request.

All statements made about ATEX conforming products are based on our present knowledge and experience. R+W reserves the right to change technical specifications.

# NOTES

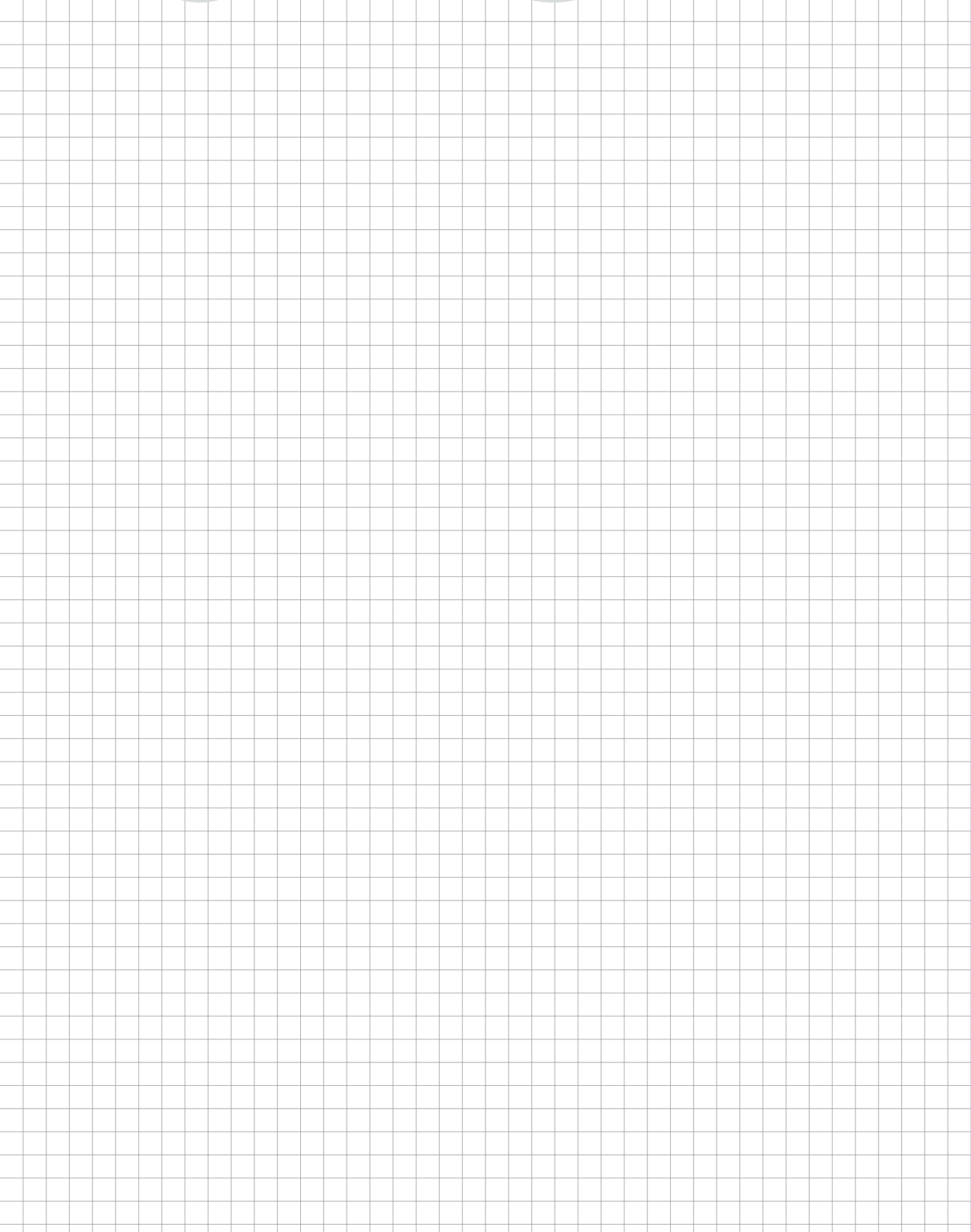

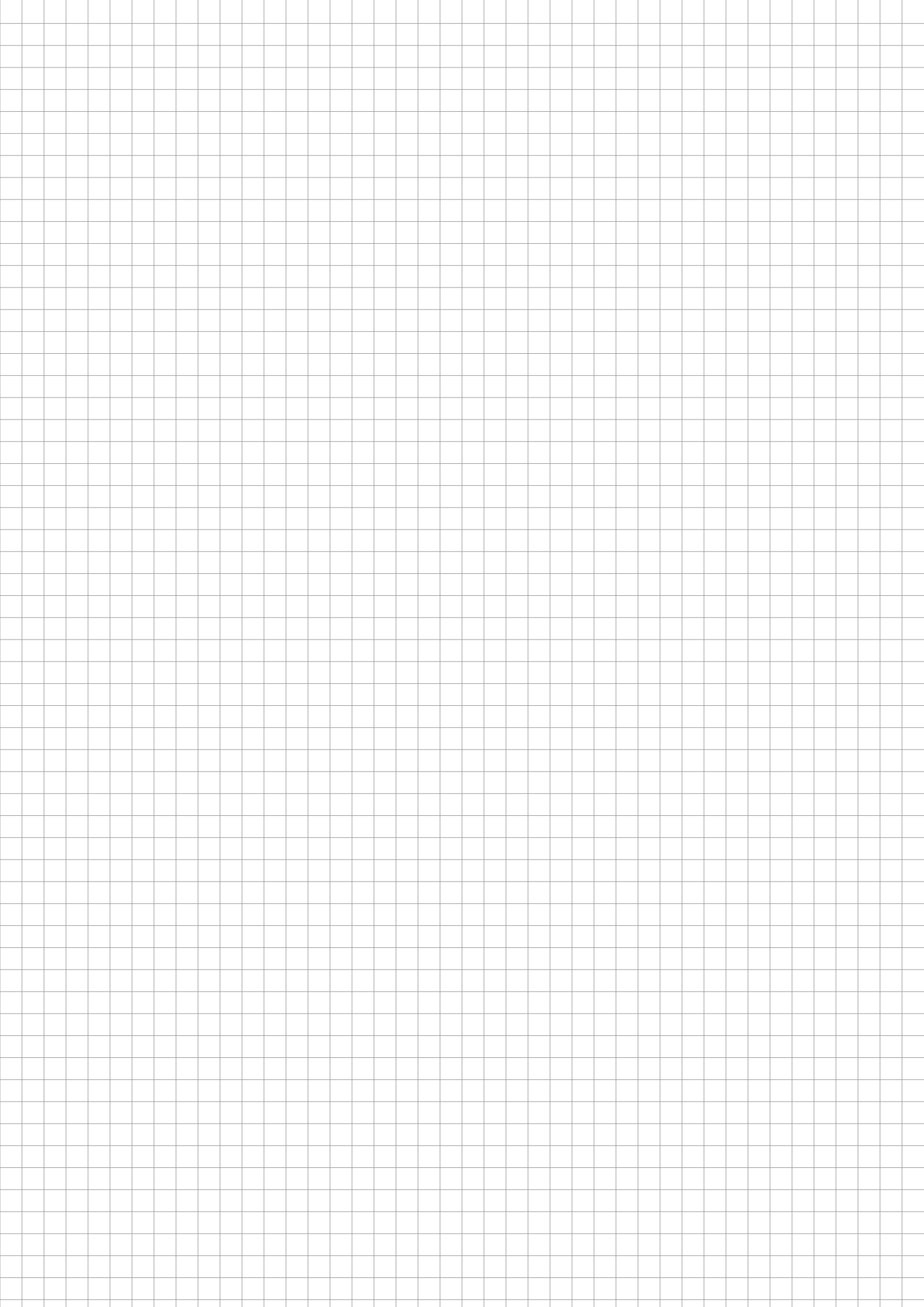

# NOTES

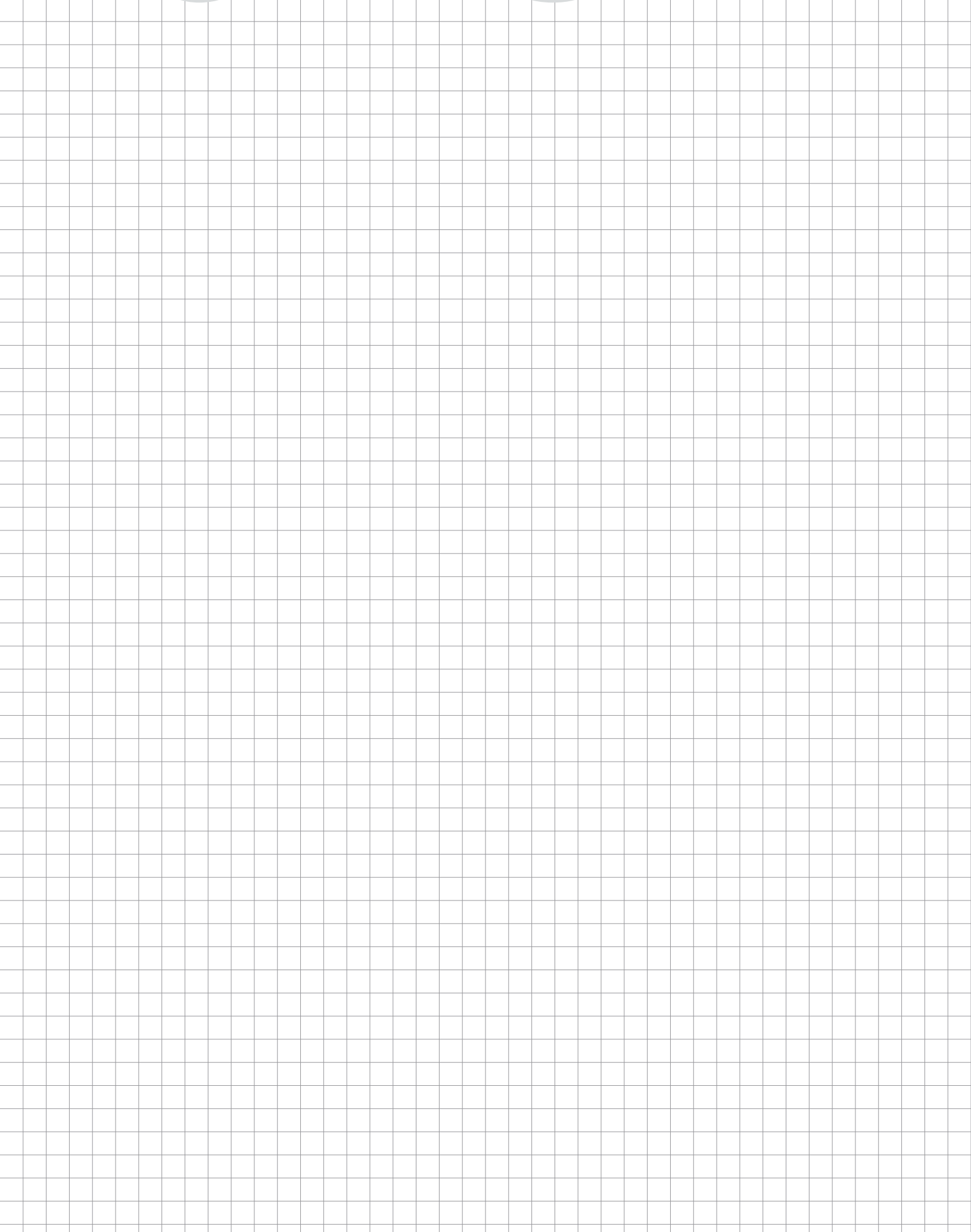

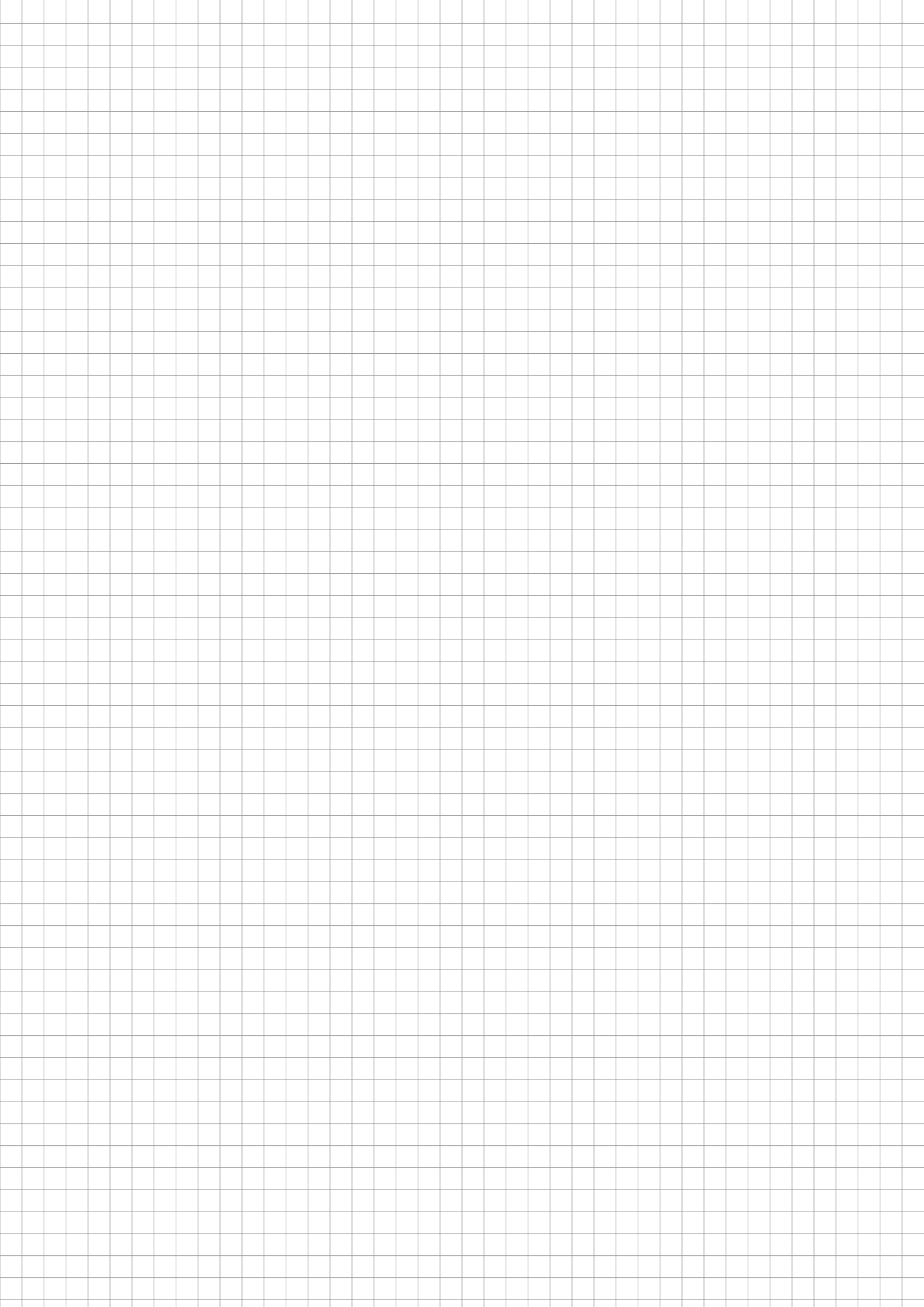

# NOTES

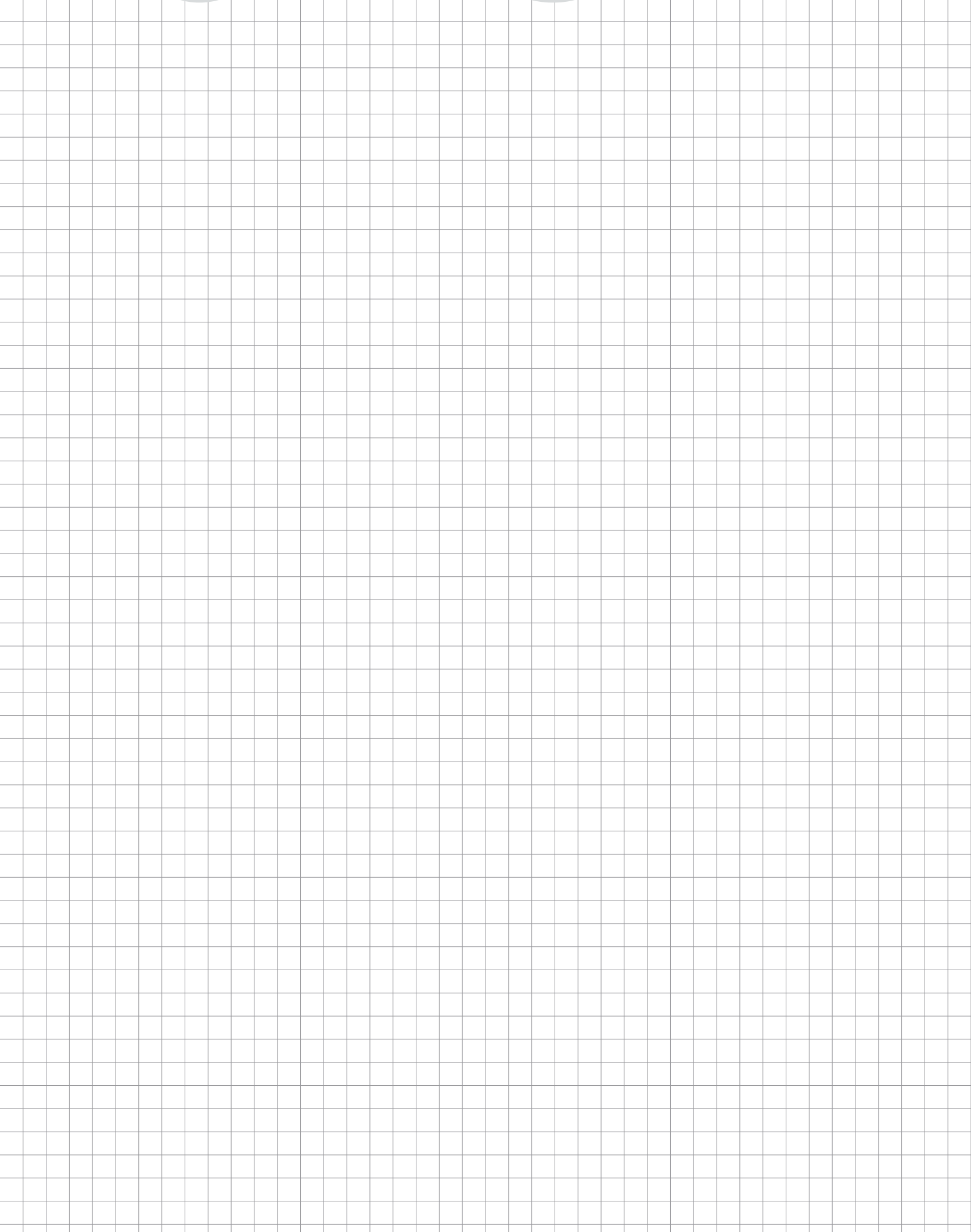

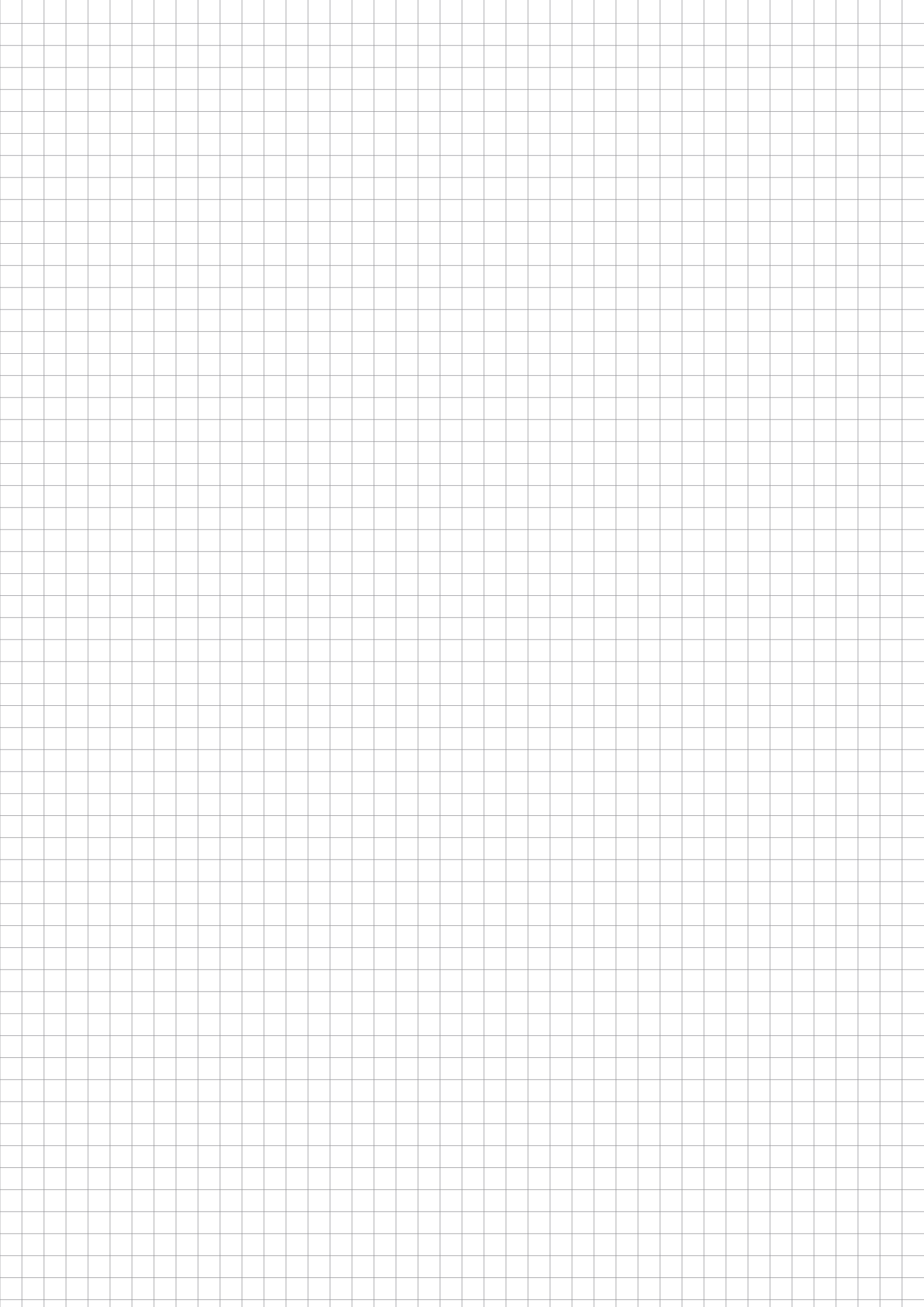

# NOTES

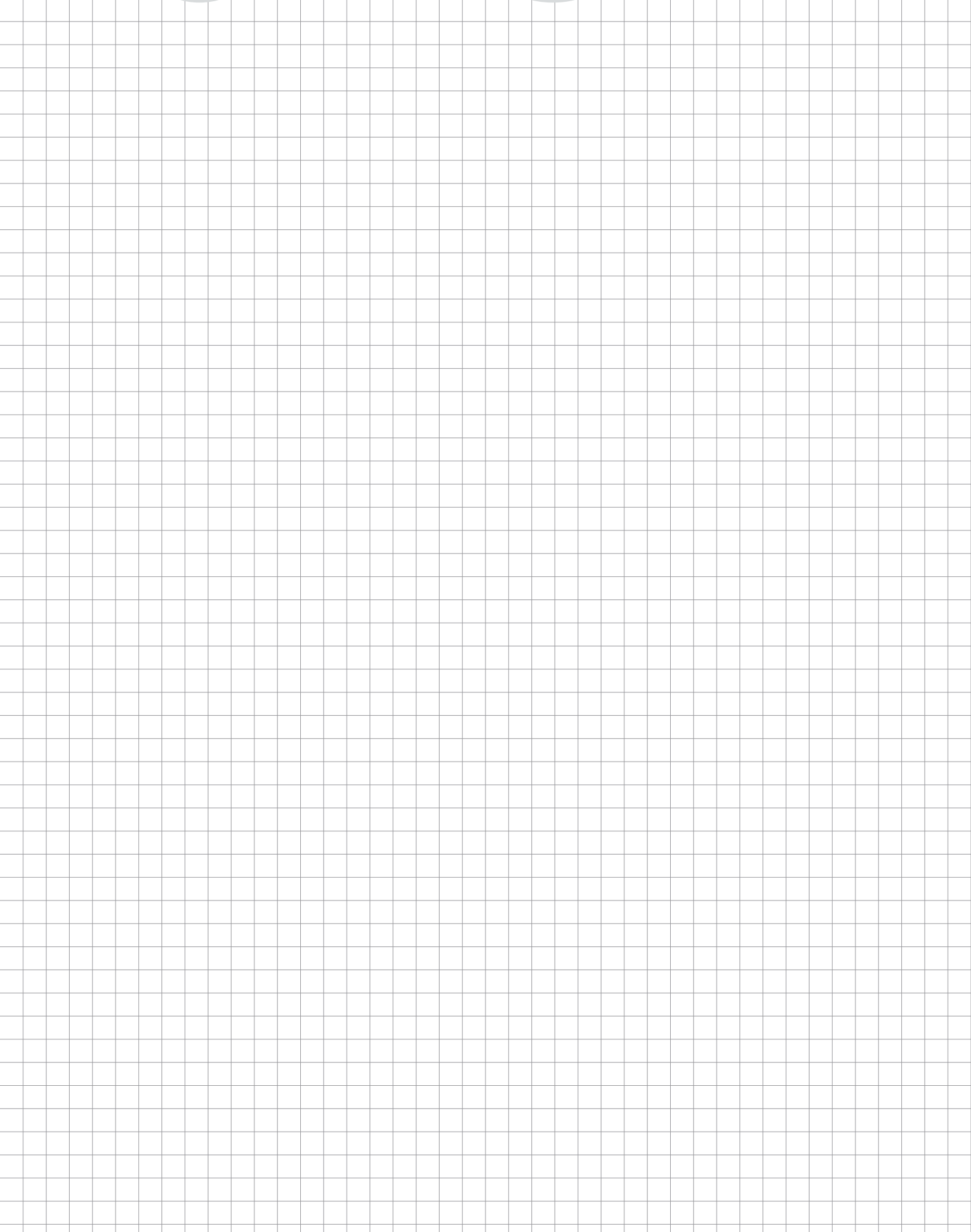



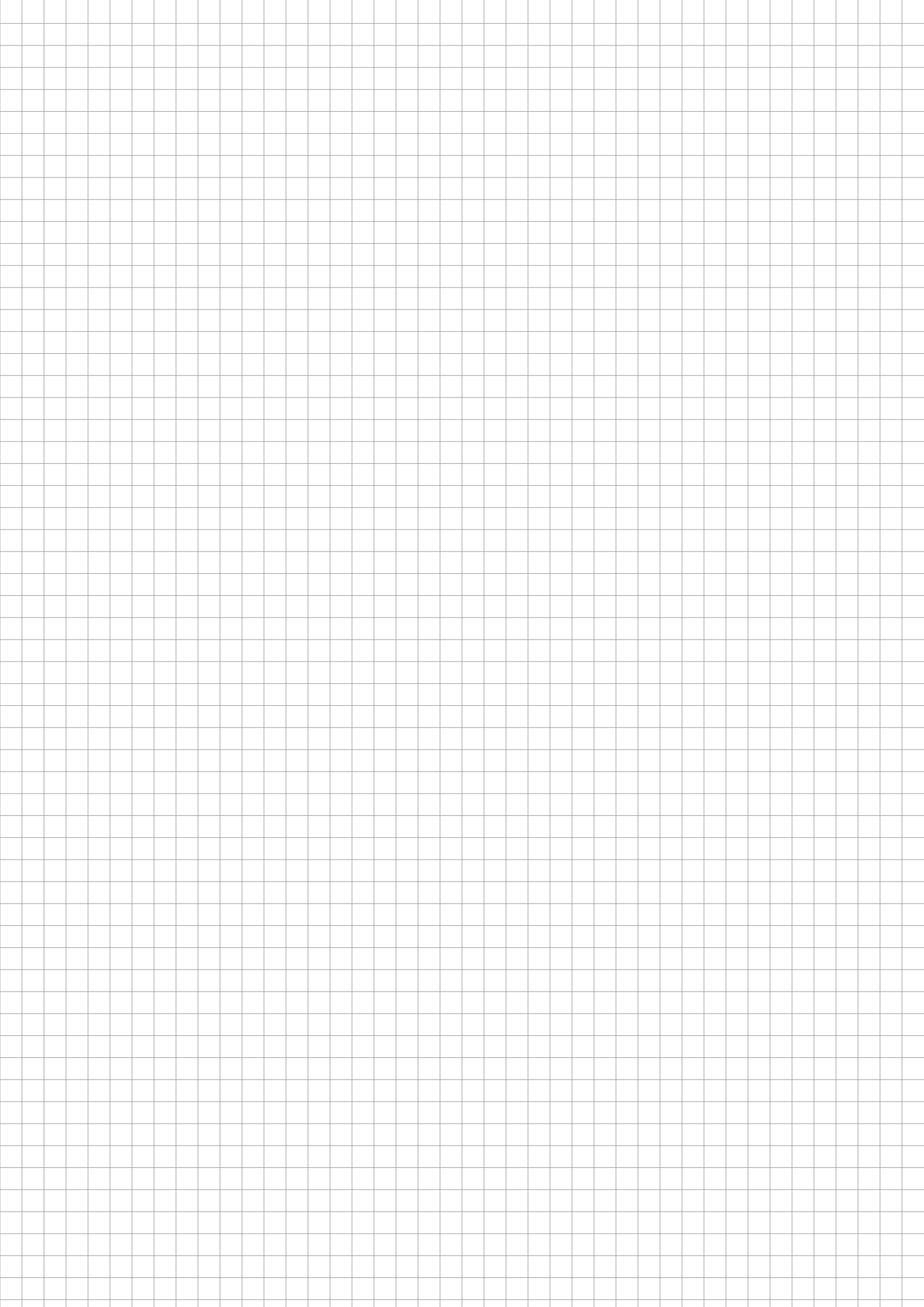

# NOTES

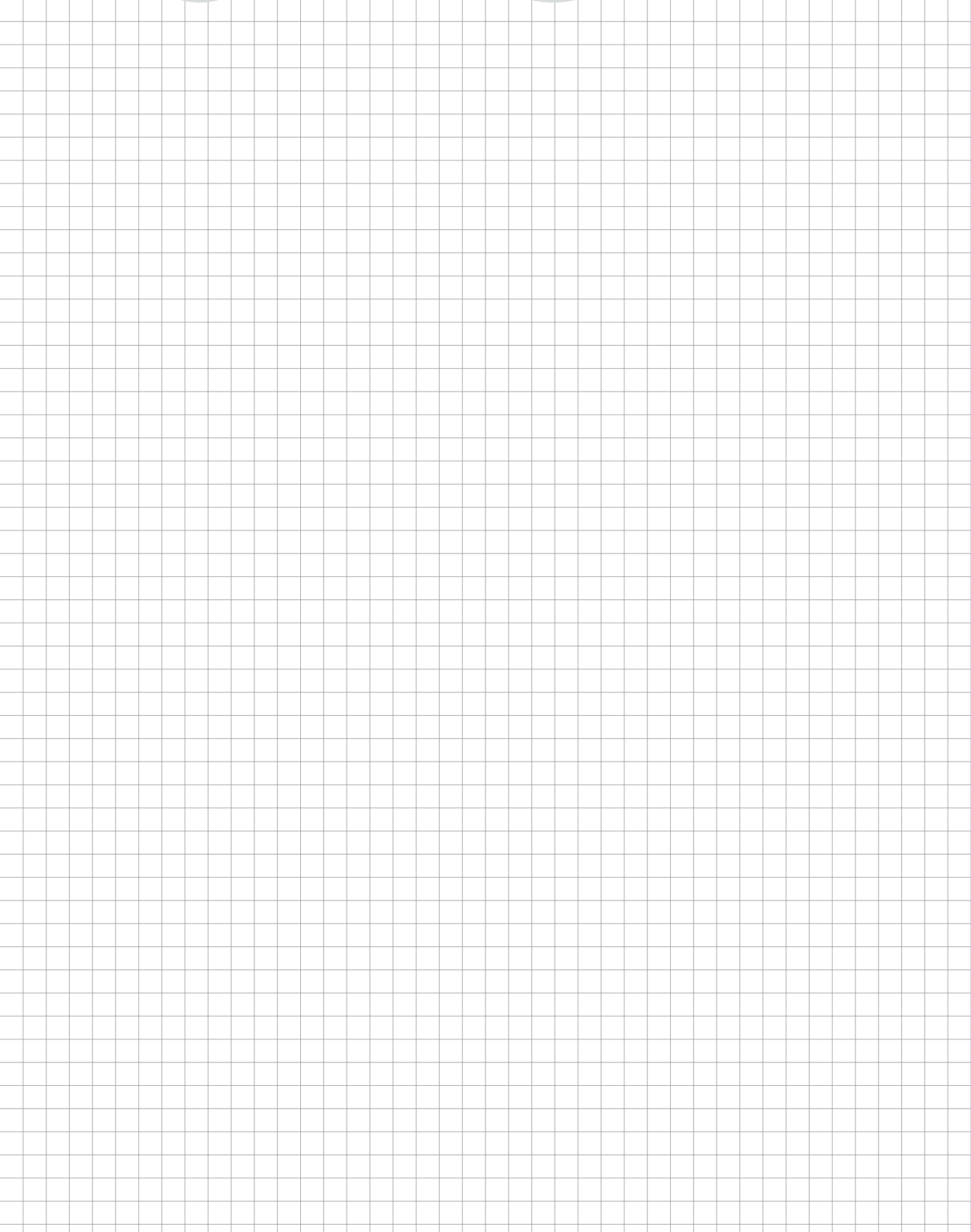

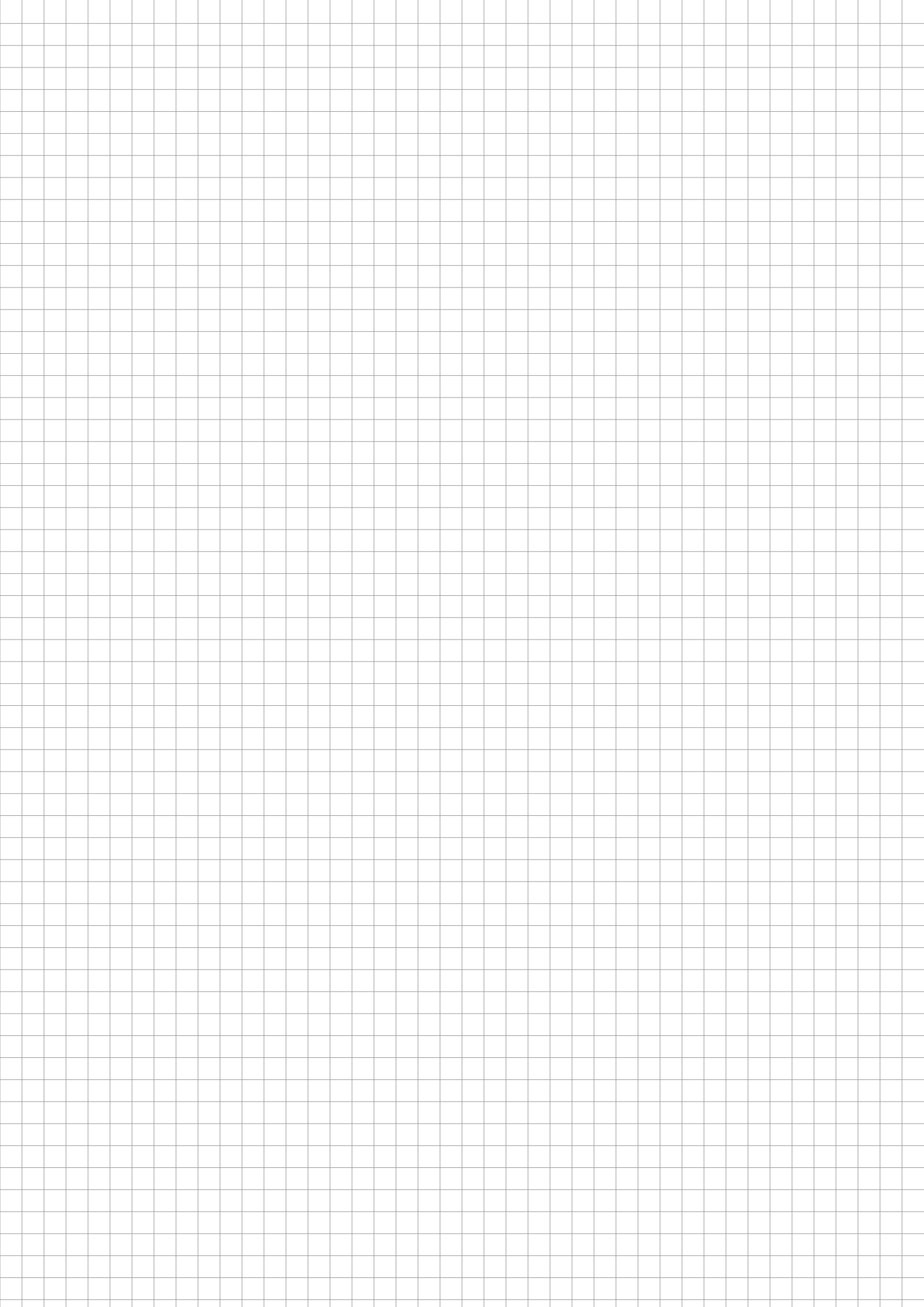

# NOTES

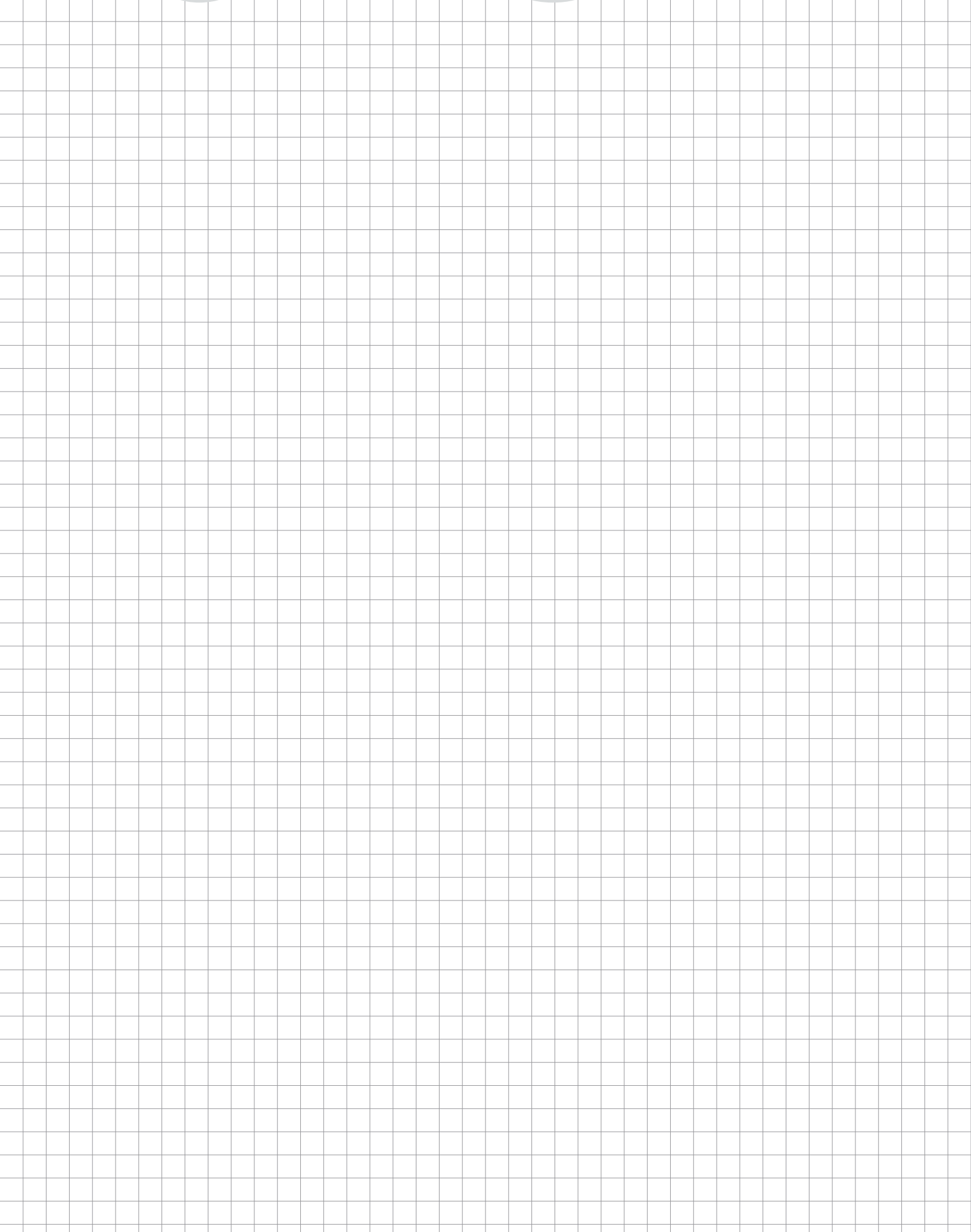

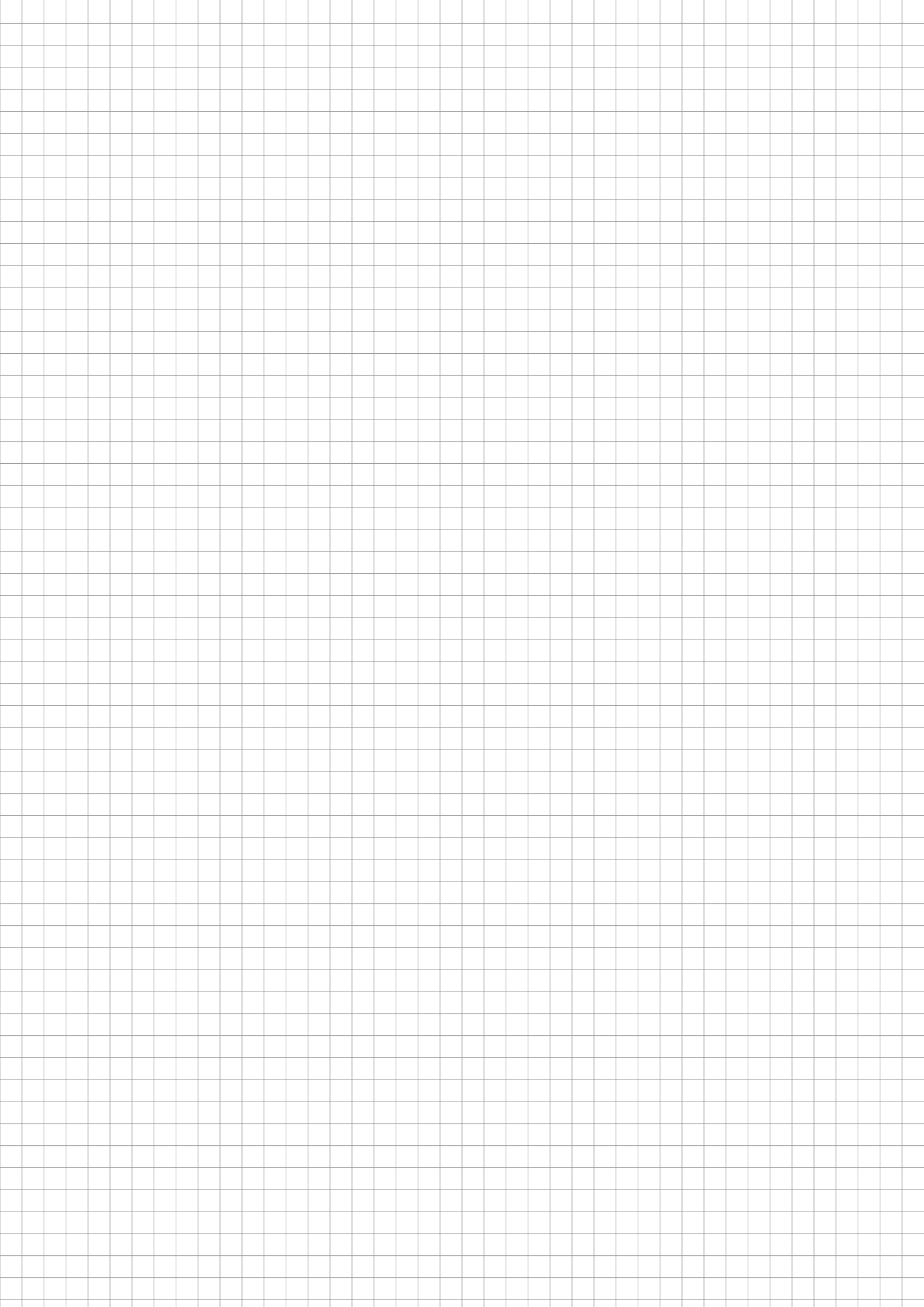

# PERFECT CONNECTIONS WORLDWIDE.

---

QUALITY "MADE IN GERMANY."



ARGENTINA | AUSTRALIA | AUSTRIA | BELGIUM | BOSNIA-HERZEGOVINA | BRAZIL | CANADA | CHILE  
| CHINA | COLOMBIA | CROATIA | CZECH REPUBLIC | DENMARK | ESTONIA | FINLAND | FRANCE |  
GREECE | HUNGARY | INDIA | INDONESIA | ISRAEL | ITALY | JAPAN | KOREA | LITHUANIA | MACEDONIA |  
MALAYSIA | MEXICO | MONTENEGRO | NETHERLANDS | NEW ZEALAND | NORWAY | PERU | PHILIPPINES  
| POLAND | PORTUGAL | ROMANIA | RUSSIA | SAUDI ARABIA | SERBIA | SINGAPORE | SLOVAKIA |  
SLOVENIA | SOUTH AFRICA | SPAIN | SWEDEN | SWITZERLAND | TAIWAN | THAILAND | TURKEY | UK  
| UKRAINE | UNITED ARAB EMIRATES | USA

#### R + W ANTRIEBSELEMENTE GMBH

Alexander-Wiegand-Strasse 8  
D - 63911 Klingenberg/Germany  
Phone +49 9372 986 40  
Fax +49 9372 986 420  
info@rw-kupplungen.de  
www.rw-kupplungen.de

#### R+W AMERICA

254 Tubeway Drive  
USA 60188 Carol Stream, IL  
Phone +1 630 521 9911  
Fax +1 630 521 0366  
info@rw-america.com  
www.rw-america.com

#### R+W MACHINERY (SHANGHAI) CO., LTD

Rm 606,999 Zhouhai Rd, Block B,  
Sunland International Building,  
Pudong Shanghai 200137  
China  
Phone +86 21 586 829 86  
Fax +86 21 586 829 95  
info@rw-china.com  
www.rw-china.com

#### R+W ITALIA S.R.I.

Via De Amicis, 67  
I - 20092 Cinisello Balsamo (MI)  
Phone +39 02 262 641 63  
Fax +39 02 243 085 64  
info@rw-italia.it  
www.rw-italia.it

#### R+W BÜRO SINGAPUR

55 Market Street #10-00  
Singapore 048941  
Phone +65 3158 4434  
Fax +65 6521 3001  
info@rw-singapore.com.sg  
www.rw-singapore.com.sg

#### R+W BÜRO ASIA PACIFIC

No. 34, Jalan Permas 9/2  
Bandar Baru Permas Jaya  
Johor Bahru 81750  
MALAYSIA  
Phone +60 177 254177  
jasontai@rwcouplings.com  
www.rwcouplings.com

#### R+W BÜRO FRANCE

249 rue Irène Joliot Curie  
F - 60610 Lacroix Saint Ouen  
Phone +33 967 124232  
Fax +33 344 434232  
Mobil +33 612 896309  
info@rw-france.fr  
www.rw-france.fr

#### QUALITY MANAGEMENT

We are certified

according to ISO 9001:2008

D-ZM-16029-01-01 Registration No. 40503432/3



The information included in this document is based on our present knowledge and experience and does not exclude the manufacturer's own substantial testing of the products. Drawings may differ from the original coupling. All data subject to change without notice. Therefore we do not guarantee protection against third party claims. The sale of our product is in accordance with our general terms and conditions.

RW-COUPLINGS.COM

**R+W** ANTRIEBSELEMENTE GMBH  
A POPPE + POTTHOFF COMPANY

ALEXANDER-WIEGAND-STRASSE 8  
D-63911 KLINGENBERG  
RW-COUPLINGS.COM

PHONE: +49 9372 9864-0  
FAX: +49 9372 9864-20  
INFO@RW-KUPPLUNGEN.DE