



# CT Series Step Motors



*Helping you build a better machine, **faster.***



# Table of Contents

- Introduction ..... 4
- Construction ..... 5
- Basic Step Motor Operation ..... 6
- Model Numbers ..... 7
- Connection Diagrams & Switching Sequences ..... 7
- CTP1 - Size 17 ..... 8 - 9
- CTP2 - Size 23 ..... 10 - 11
- CTP3 - Size 34 ..... 12 - 13
- Conversion Factors ..... 14

## Danaher Motion has combined high performance step motor designs with Far Eastern manufacturing capabilities to create the new CT Series.

CT Series motors incorporate innovative cooling technology (patent pending), high torque magnetic designs, rugged bearings, and high voltage insulation systems. These features provide high torque motors, which support large mechanical loads, and can be used with all drives.

Outstanding performance is only part of the CT story. CT Series motors are available in the most popular sizes (17, 23, and 34), and are available in a variety of lengths, windings and shafts.

### Custom Motors

Danaher Motion routinely provides motors with many types of modifications. Please contact us with your specific requirements.

#### Shaft Modifications

A variety of motor output shaft modifications can be supplied. These include special flats and keyways, lengths, diameters, through holes and similar changes which may be needed to allow mounting of timing belts, pulleys or gears or to facilitate mounting the motor to the equipment being driven.

#### Electrical Modifications

Motors can be supplied with a number of electrical modifications, including: nonstandard lead lengths, electrical connectors and special windings.



## CT Series Step Motors . . . run cooler, produce more torque, and support higher shaft loads than any other step motor.

### High Torque Magnetic Design (patented)

Large rotor diameter, small air gap, high energy rotor magnets and computer controlled winding.

Benefits:

- More torque output
- Higher acceleration

### Cooling Shell (patent pending)

Aluminum shell and aluminum end-caps quickly remove heat from the motor. This allows for higher current ratings, especially when the motor is mounted.

Benefits:

- Increased torque output
- Longer life – lower temperatures
- Smaller motors can be used

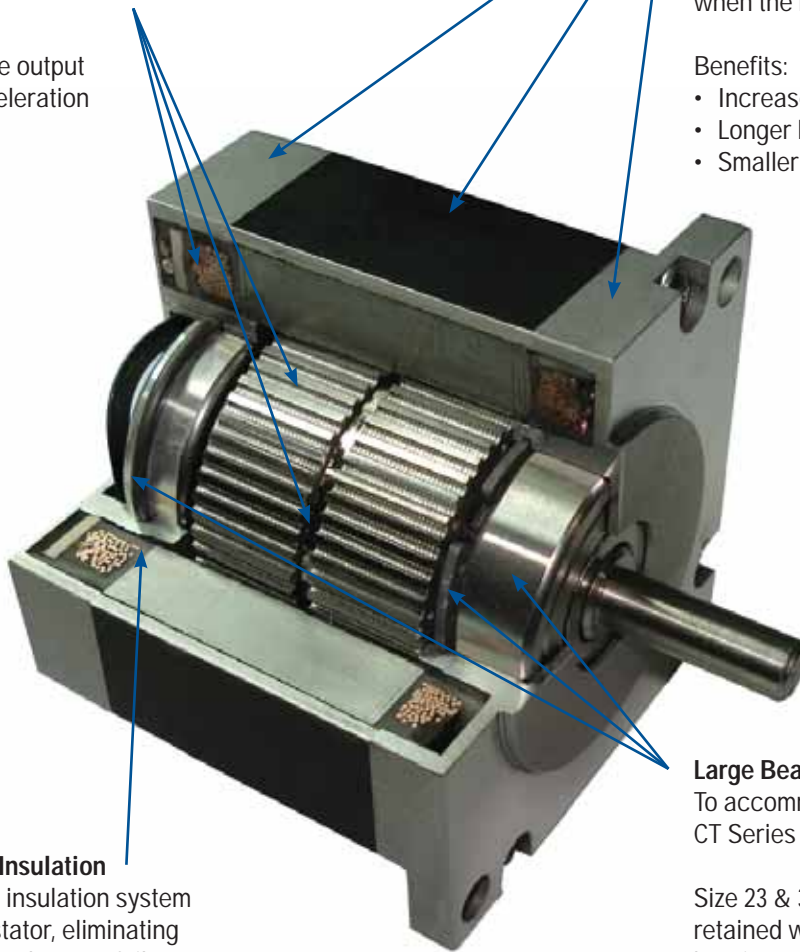

### High Voltage Insulation

Insert molded insulation system encases the stator, eliminating joints and gaps that can fail.

Benefits:

- Motors can be used with high voltage, high performance drives
- Extended motor life
- Higher reliability

### Large Bearing System

To accommodate large mechanical loads, CT Series motors feature large bearings.

Size 23 & 34 motors have the front bearing retained with a snap ring, and the rear bearing mounted in an O-ring to prevent spinout and minimize motor noise.

Benefits:

- Lower system costs. Loads can be directly mounted on motor shaft eliminating couplings and load support bearings
- Excellent for leadscrew applications
- Longer motor life

## Basic Step Motor Operation

CT Series step motors have two windings (two phases) which are energized with DC current. When the current in one winding is reversed, the motor shaft moves one step, or  $1.8^\circ$ , and the shaft is magnetically held in the new position. By sequentially switching the current in each winding the position and speed of the motor is easily and precisely controlled. Simple control combined with high torque output makes these motors extremely useful for many different motion control applications.

For even finer resolution and smoother operation, micro-stepping drives divide each step into many increments by controlling the magnitude of the current in each winding.

The performance of hybrid step motors is highly dependent on the current and voltage supplied by a drive. CT Series step motors can be used with a variety of drives that have a broad range of voltage and current ratings.

### Holding Torque

Because motor performance varies greatly with the drive, holding torque is often used as a figure of merit when comparing hybrid step motors. Holding torque specifies the maximum torque that can be applied to a motor shaft and not cause the shaft to rotate. It is measured with the motor at standstill and energized with rated DC current. Since the motor is energized with pure DC current, holding torque is not dependent on specific drive characteristics.

### Torque-Speed Curves

As the applied voltage and/or current to the motor is changed, motor performance is altered. Figures 1 and 2 show typical torque-speed curves using a bipolar chopper driver.

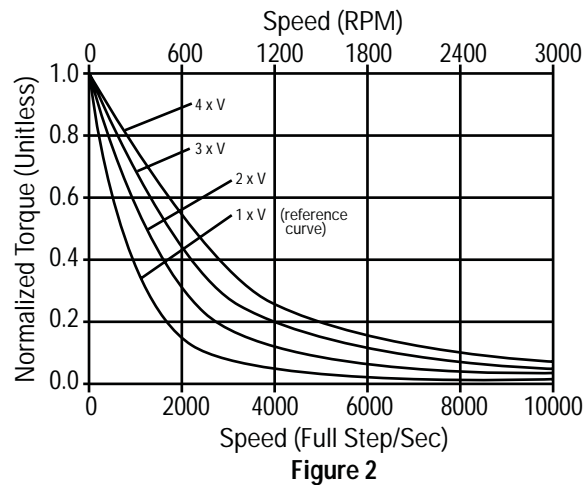
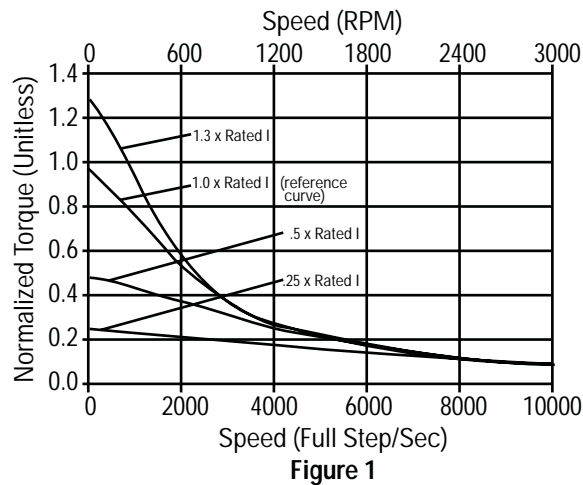

**Figure 1** shows the performance of the same motor driven by a bipolar chopper drive at different current settings. All drivers have the same supply voltage. Note that high speed performance is not appreciably affected by the different current settings. Low speed running torque, however, varies considerably with changes in the drive current setting. When current higher than the rated current of the motor is applied, torque and motor temperature will increase (particularly at low speeds). Very high currents will damage the motor due to demagnetization and/or overheating.

**Figure 2** shows the performance of the same motor driven by a bipolar chopper driver with different supply voltages. All drivers have the same current setting. Note that low speed running torque is not appreciably affected by supply voltage differences. High speed performance, however, varies considerably with changes in supply voltage. Caution must be exercised when increasing supply voltage as higher voltages will result in increased motor heating.

# CT Series Model Numbers

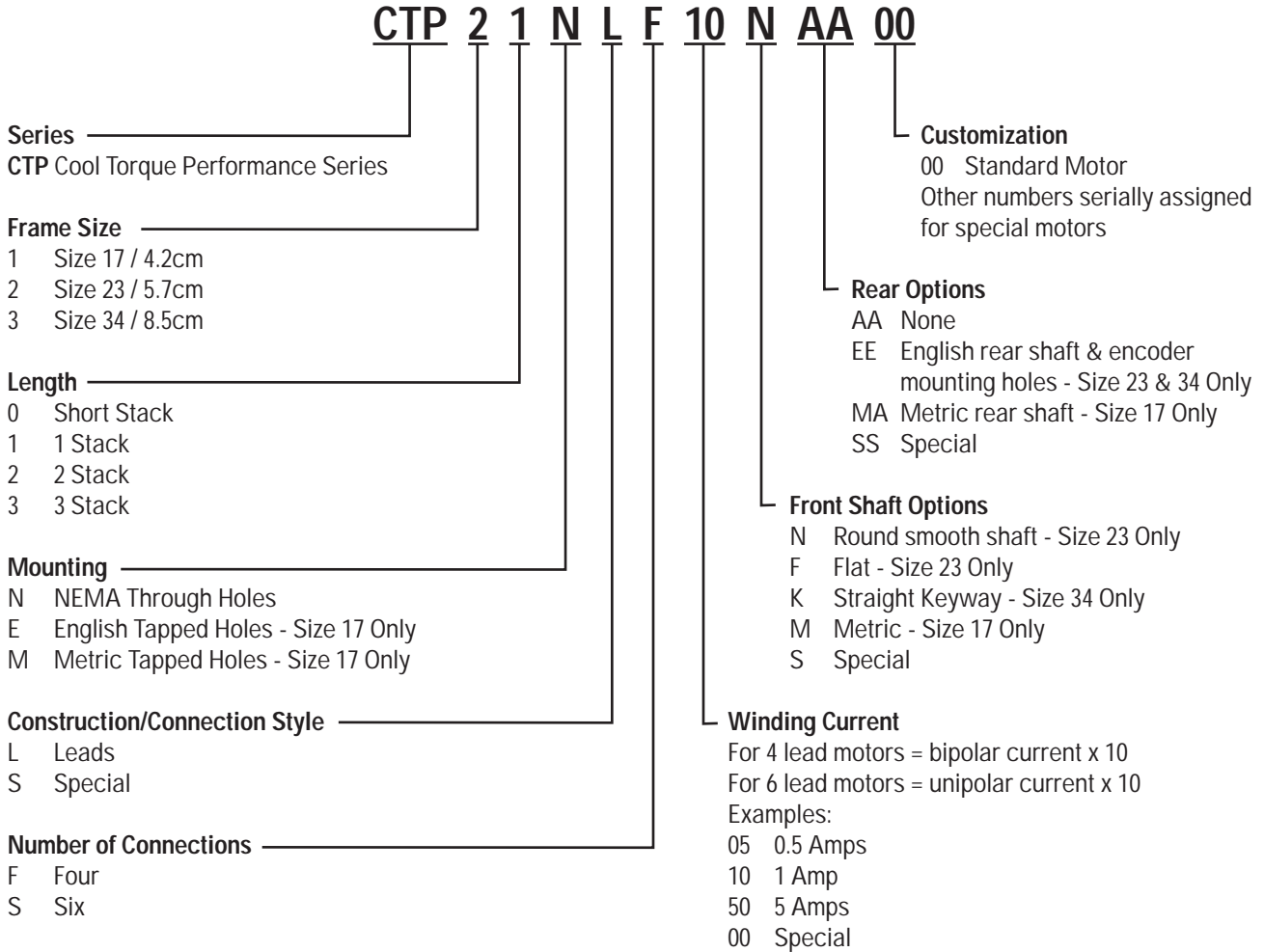

# CT Series Connection Diagrams & Switching Sequences

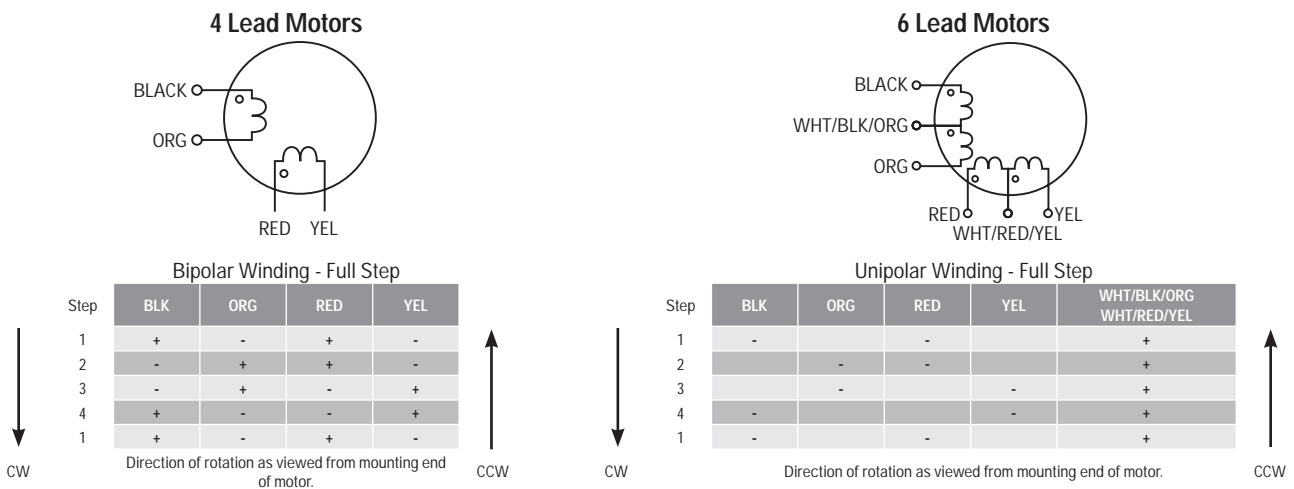

## CTP1-Size 17

- High torque
- Inch or metric mounting
- RoHS Compliant
- Custom Motors

Phases	2
Full Steps per Revolution	200
Step Angle	1.8°
Step Accuracy	±5%
Operating Temperature	-20°C to +40°C
Insulation Class	Class B, 130°C
Insulation Voltage Rating	100 VDC
Insulation Resistance	100 Megohms
Shaft Load	(20,000 hrs at 1,500 rpm)
Radial	15 lbs (6.8 kg) at shaft center
Axial	6 lbs (2.7 kg) push 15 lbs (6.8) pull

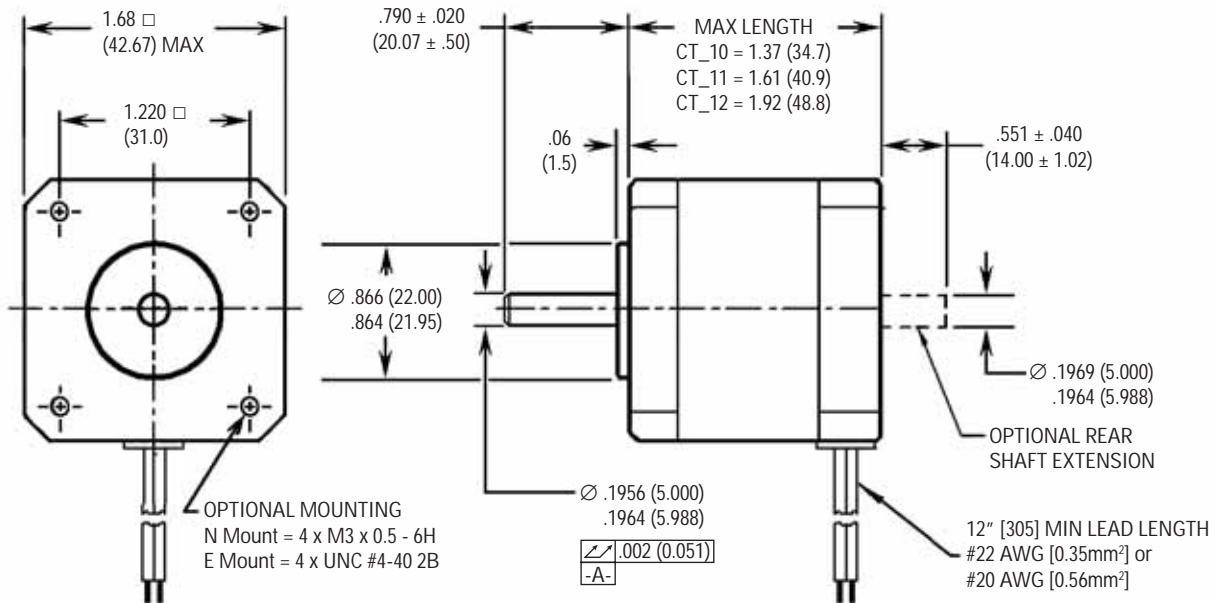

Series	Motor Torque Motor Mounted				Detent Torque		Thermal Resistance Mounted °C/watt	Rotor Inertia		Net Weight	
	Bipolar		Unipolar		Typical			oz-in-S <sup>2</sup>	kg-cm <sup>2</sup>	lbs	kg
	oz-in	N-m	oz-in	N-m	oz-in	N-m					
CTP10	43	0.30	33	0.23	2	0.014	6.21	0.00051	0.04	0.45	0.20
CTP11	62	0.44	49	0.35	2.5	0.018	5.44	0.00075	0.05	0.57	0.26
CTP12	80	0.56	62	0.44	3	0.021	4.71	0.00106	0.07	0.76	0.34



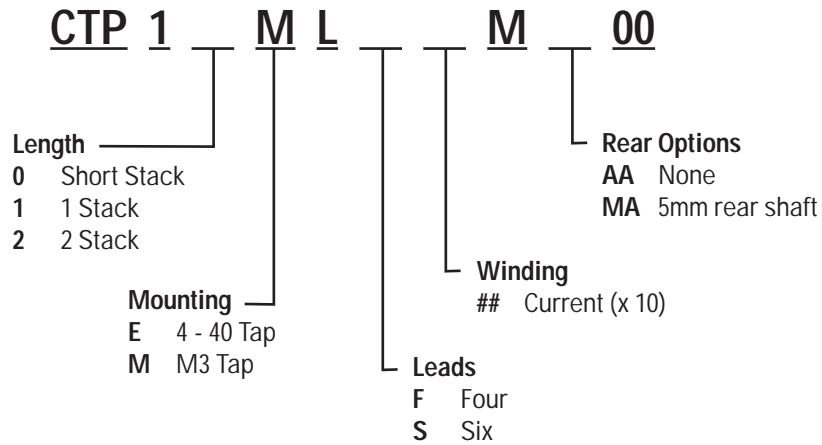

**4 Lead Motors - Bipolar Ratings**

Size 17	Model Number (basic English mount)	Current amps DC	Voltage VDC	Resistance ohms ±10%	Inductance mH Typical
Short Stack	CTP10ELF16MAA00	1.6	3.4	2.15	3.0
	CTP10ELF10MAA00	1.0	5.2	5.25	7.7
	CTP10ELF06MAA00	0.63	8.1	12.8	18
	CTP10ELF04MAA00	0.40	12.5	30.5	42
1 Stack	CTP11ELF17MAA00	1.7	3.6	2.12	4.2
	CTP11ELF11MAA00	1.1	5.5	5.19	11
	CTP11ELF07MAA00	0.68	8.5	12.5	26
	CTP11ELF04MAA00	0.44	13.4	30.4	60
2 Stack	CTP12ELF26MAA00	2.6	2.8	1.09	1.9
	CTP12ELF16MAA00	1.6	4.3	2.65	4.9
	CTP12ELF10MAA00	1.0	6.6	6.51	12
	CTP12ELF07MAA00	0.65	10.2	15.7	30

**6 Lead Motors - Unipolar Ratings**

Size 17	Model Number (basic English mount)	Current amps DC	Voltage VDC	Resistance ohms ±10%	Inductance mH Typical
Short Stack	CTP10ELS12MAA00	1.2	4.2	3.38	2.40
	CTP10ELS08MAA00	0.80	6.4	8.04	5.5
	CTP10ELS05MAA00	0.50	9.9	19.4	13
	CTP10ELS03MAA00	0.33	15.6	47.1	31
1 Stack	CTP11ELS13MAA00	1.3	4.4	3.31	3.4
	CTP11ELS09MAA00	0.85	6.8	8.02	8.0
	CTP11ELS06MAA00	0.55	10.4	18.9	18
	CTP11ELS03MAA00	0.35	16.8	48.1	47
2 Stack	CTP12ELS20MAA00	2.0	3.5	1.70	1.6
	CTP12ELS13MAA00	1.3	5.3	4.13	3.9
	CTP12ELS08MAA00	0.82	8.2	10.1	9.2
	CTP12ELS05MAA00	0.53	12.6	23.8	21

Rated current is per phase, with the motor mounted, and winding temperature rise  $\Delta T = 90^{\circ}\text{C}$ . Resistance is with winding at  $20^{\circ}\text{C}$ .

## CTP2-Size 23

- High torque
- Heavy duty bearings - excellent for use with leadscrews
- High voltage insulation system
- RoHS Compliant
- Custom Motors

Phases	2
Full Steps per Revolution	200
Step Angle	1.8°
Step Accuracy	±3%
Operating Temperature	-20°C to +40°C
Insulation Class	Class B, 130°C
Insulation Voltage Rating	340 VDC
Insulation Resistance	100 Megohms
Shaft Load	(20,000 hrs at 1,500 rpm)
Radial	20 lbs. (9 kg) at shaft center
Axial	50 lbs. (23 kg) both directions

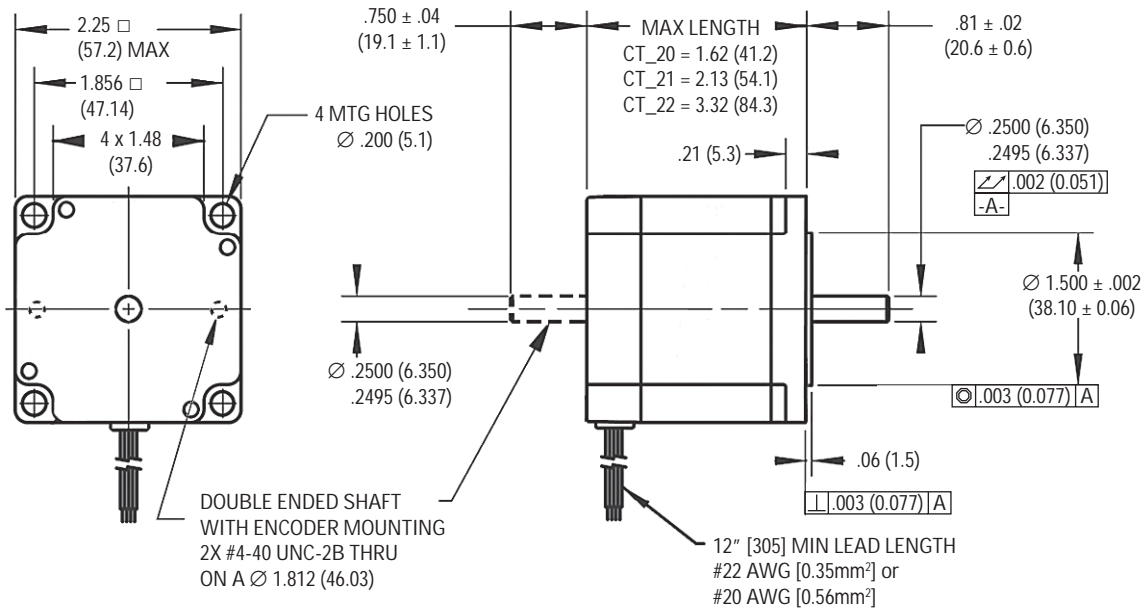

Series	Motor Torque Motor Mounted				Detent Torque		Thermal Resistance Mounted °C/watt	Rotor Inertia		Net Weight	
	Bipolar		Unipolar		Typical			oz-in-S <sup>2</sup>	kg-cm <sup>2</sup>	lbs	kg
	oz-in	N-m	oz-in	N-m	oz-in	N-m					
CTP20	100	0.71	75	0.53	4	0.03	3.99	0.0026	0.19	1.0	0.45
CTP21	200	1.41	160	1.13	7	0.05	3.57	0.0035	0.24	1.4	0.65
CTP22	360	2.54	285	2.01	10	0.07	2.62	0.0068	0.48	2.4	1.10

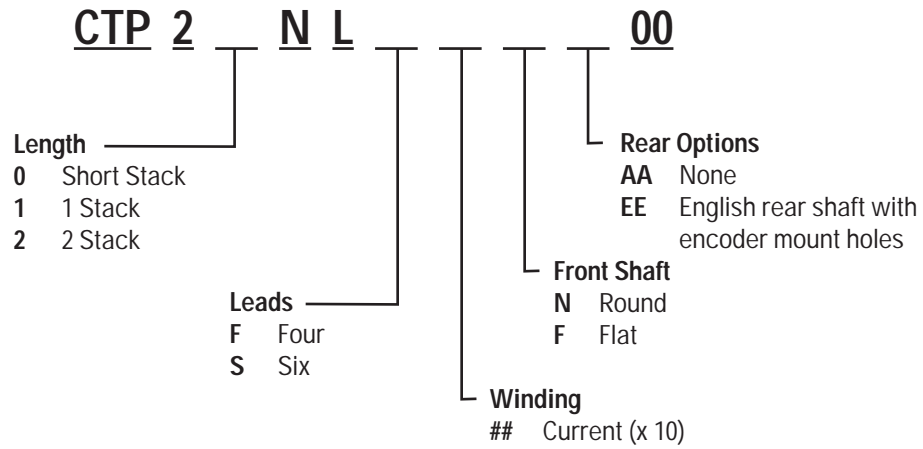

**4 Lead Motors - Bipolar Ratings**

Size 23	Model Number (base motor)	Current amps DC	Voltage VDC	Resistance ohms ±10%	Inductance mH Typical
Short Stack	CTP20NLF27NAA00	2.7	3.0	1.11	2.5
	CTP20NLF17NAA00	1.7	4.8	2.87	7.1
	CTP20NLF11NAA00	1.1	7.4	6.98	17
	CTP20NLF07NAA00	0.68	11.6	17.1	41
	CTP20NLF04NAA00	0.45	17.8	40.6	89
1 Stack	CTP21NLF39NAA00	3.9	2.4	0.60	2.2
	CTP21NLF25NAA00	2.5	3.7	1.48	5.8
	CTP21NLF15NAA00	1.5	5.9	3.86	16
	CTP21NLF10NAA00	1.0	9.1	9.40	38
	CTP21NLF04NAA00	0.45	19.8	44.0	170
2 Stack	CTP22NLF50NAA00	5.0	2.6	0.52	2.2
	CTP22NLF31NAA00	3.1	4.0	1.31	6.1
	CTP22NLF19NAA00	1.9	6.3	3.25	16
	CTP22NLF12NAA00	1.2	10.1	8.40	41
	CTP22NLF06NAA00	0.6	19.6	32.2	150

**6 Lead Motors - Unipolar Ratings**

Size 23	Model Number (base motor)	Current amps DC	Voltage VDC	Resistance ohms ±10%	Inductance mH Typical
Short Stack	CTP20NLS34NAA00	3.4	2.5	0.73	0.83
	CTP20NLS21NAA00	2.1	3.8	1.83	2.2
	CTP20NLS13NAA00	1.3	5.9	4.39	5.2
	CTP20NLS09NAA00	0.87	9.1	10.5	12
1 Stack	CTP21NLS48NAA00	4.8	2.0	0.41	0.74
	CTP21NLS31NAA00	3.1	3.0	0.97	1.9
	CTP21NLS19NAA00	1.9	4.7	2.44	5.0
	CTP21NLS12NAA00	1.2	7.2	5.89	12
2 Stack	CTP22NLS49NAA00	4.9	2.6	0.53	1.2
	CTP22NLS31NAA00	3.1	4.0	1.30	3.0
	CTP22NLS19NAA00	1.9	6.4	3.39	8.3
	CTP22NLS12NAA00	1.2	10.0	8.26	20

Rated current is per phase, with the motor mounted, and winding temperature rise  $\Delta T = 90^{\circ}C$ . Resistance is with winding at  $20^{\circ}C$ .

## CTP3-Size 34

- High torque
- Captured front bearing - excellent for use with leadscrews
- High voltage insulation system
- RoHS Compliant
- Custom Motors

Phases	2
Full Steps per Revolution	200
Step Angle	1.8°
Step Accuracy	±3%
Operating Temperature	-20°C to ±40°C
Insulation Class	Class B, 130°C
Insulation Voltage Rating	340 VDC
Insulation Resistance	100 Megohms
Shaft Load	(20,000 hrs at 1,500 rpm)
Radial	65 lbs. (29 kg) at shaft center
Axial	100 lbs. (45 kg) both directions

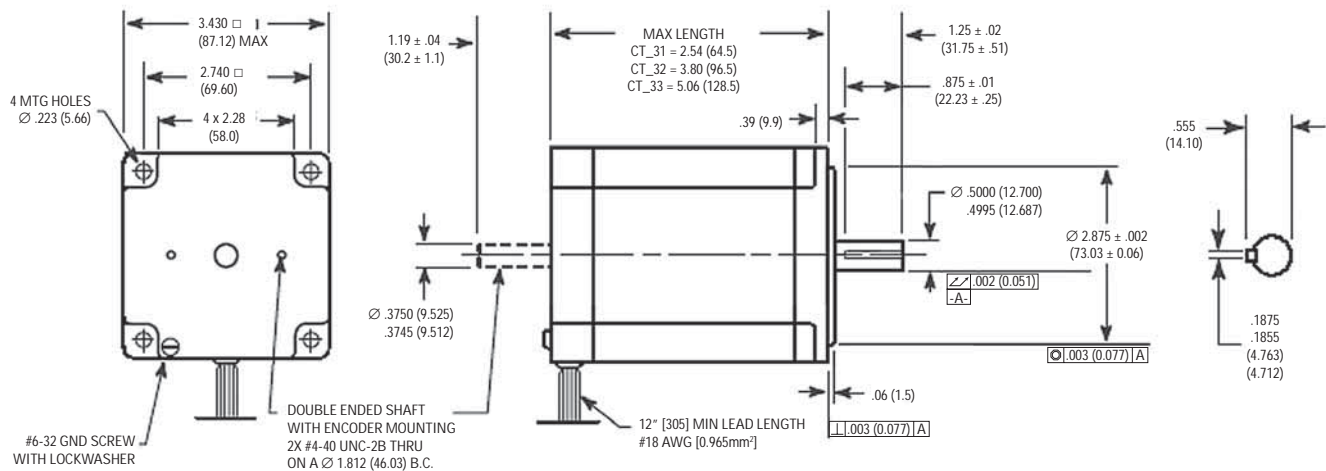
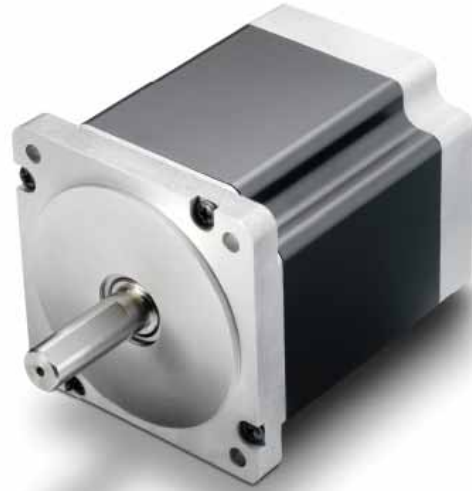

Series	Motor Torque Motor Mounted				Detent Torque		Thermal Resistance Mounted °C/watt	Rotor Inertia		Net Weight	
	Bipolar		Unipolar		Typical			oz-in-S <sup>2</sup>	kg-cm <sup>2</sup>	lbs	kg
	oz-in	N-m	oz-in	N-m	oz-in	N-m					
CTP31	565	4.0	460	3.3	22	0.16	2.02	0.0185	1.31	4.0	1.8
CTP32	1100	7.8	890	6.3	30	0.21	1.55	0.0370	2.61	6.5	3.0
CTP33	1570	11	1250	8.8	38	0.27	1.36	0.0555	3.92	9.1	4.1

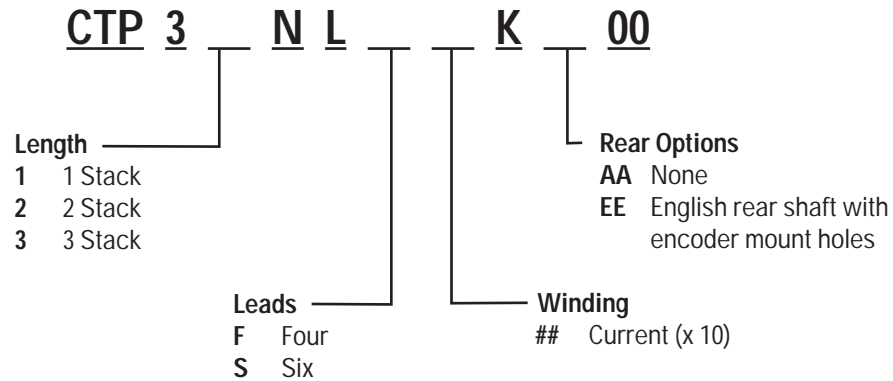

**4 Lead Motors - Bipolar Ratings**

Size 34	Model Number (base motor)	Current amps DC	Voltage VDC	Resistance ohms ±10%	Inductance mH Typical
1 Stack	CTP31NLF72KAA00	7.2	2.4	0.34	2.3
	CTP31NLF45KAA00	4.5	3.6	0.79	5.8
	CTP31NLF28KAA00	2.8	5.7	2.02	16
	CTP31NLF09KAA00	0.9	17.3	19.5	150
2 Stack	CTP32NLF73KAA00	7.3	3.0	0.41	3.4
	CTP32NLF46KAA00	4.6	4.6	1.01	9.1
	CTP32NLF28KAA00	2.8	7.2	2.53	24
	CTP32NLF11KAA00	1.1	18.0	16.1	150
3 Stack	CTP33NLF75KAA00	7.5	3.4	0.45	4.0
	CTP33NLF47KAA00	4.7	5.1	1.08	10
	CTP33NLF29KAA00	2.9	8.0	2.73	27
	CTP33NLF13KAA00	1.3	17.8	13.8	140

**6 Lead Motors - Unipolar Ratings**

Size 34	Model Number (base motor)	Current amps DC	Voltage VDC	Resistance ohms ±10%	Inductance mH Typical
1 Stack	CTP31NLS56KAA00	5.6	3.0	0.53	1.9
	CTP31NLS35KAA00	3.5	4.5	1.29	4.9
	CTP31NLS22KAA00	2.2	7.1	3.21	13
2 Stack	CTP32NLS58KAA00	5.8	3.7	0.65	2.8
	CTP32NLS36KAA00	3.6	5.8	1.63	7.6
	CTP32NLS23KAA00	2.3	9.0	4.00	19
3 Stack	CTP33NLS59KAA00	5.9	4.1	0.70	3.2
	CTP33NLS37KAA00	3.7	6.4	1.74	8.4
	CTP33NLS23KAA00	2.3	10.0	4.31	21

Rated current is per phase, with the motor mounted, and winding temperature rise  $\Delta T = 90^{\circ}\text{C}$ . Resistance is with winding at  $20^{\circ}\text{C}$ .

## Conversion Factors

### Length

A \ B	mm	cm	m	inch	feet
mm	---	0.1	0.001	0.03937	0.003281
cm	10	---	0.01	0.3937	0.03281
m	1000	100	---	39.37	3.281
inch	25.4	2.54	0.0254	---	0.08333
feet	304.8	30.48	0.3048	12	---

Multiply units of "A" by indicated factor to obtain units of "B"

### Force

A \ B	g	kg	oz	lb	Newton
g	---	0.001	0.03527	0.002205	0.0098
kg	1000	---	35.27	2.205	9.807
oz	28.35	0.02835	---	0.0625	0.278
lb	453.6	0.4536	16	---	4.448
Newton	102	0.102	3.597	0.2248	---

Multiply units of "A" by indicated factor to obtain units of "B"

### Inertia

A \ B	kgm <sup>2</sup>	kgcm <sup>2</sup>	gcm <sup>2</sup>	oz-in <sup>2</sup>	oz-in-sec <sup>2</sup>	lb-in <sup>2</sup>	lb-in-sec <sup>2</sup>	lb-ft <sup>2</sup>	lb-ft-sec <sup>2</sup> (slug ft <sup>2</sup> )
kgm <sup>2</sup>	---	10,000	1 x 10 <sup>7</sup>	54,670	141.6	3,418	8.851	23.73	0.7376
kgcm <sup>2</sup>	0.0001	---	1,000	5.457	0.01416	0.3418	0.000885	0.002373	7.376 x 10 <sup>-5</sup>
gcm <sup>2</sup>	1.00 x 10 <sup>-7</sup>	0.001	---	0.005467	1.416 x 10 <sup>-5</sup>	0.000342	8.851 x 10 <sup>-7</sup>	2.373 x 10 <sup>-6</sup>	7.376
oz-in <sup>2</sup>	1.829 x 10 <sup>-5</sup>	0.1829	182.9	---	0.00259	0.0625	0.000162	0.000434	1.349 x 10 <sup>-5</sup>
oz-in-sec <sup>2</sup>	0.00706	70.61	70,610	386.1	---	24.13	0.0625	0.1676	0.00521
lb-in <sup>2</sup>	0.000293	2.926	2,926	0.16	0.04144	---	0.00259	0.006944	0.000216
lb-in-sec <sup>2</sup>	0.113	1,130	1.13 x 10 <sup>6</sup>	6,177	16	386.1	---	2.681	0.0833
lb-ft <sup>2</sup>	0.04214	421.4	4.214 x 10 <sup>5</sup>	2,304	5.968	144	0.373	---	0.0318
lb-ft-sec <sup>2</sup> (slug ft <sup>2</sup> )	1.356	13,560	1.356 x 10 <sup>7</sup>	74,130	192	4.633 x 10 <sup>5</sup>	12	32.17	---

Multiply units of "A" by indicated factor to obtain units of "B"

### Torque

A \ B	Nm	Ncm	dyn cm	kgm <sup>(1)</sup>	kgcm <sup>(1)</sup>	gcm <sup>(1)</sup>	oz-in	lb-ft	lb-in
Nm	---	100	1 x 10 <sup>7</sup>	0.102	10.20	10,200	141.6	0.7376	8.851
Ncm	0.01	---	1 x 10 <sup>5</sup>	0.00102	0.102	102	1.416	0.007376	0.08851
dyn cm	1 x 10 <sup>-7</sup>	1 x 10 <sup>-5</sup>	---	1.02 x 10 <sup>-8</sup>	1.02 x 10 <sup>-6</sup>	0.00102	1.416 x 10 <sup>-5</sup>	7.376 x 10 <sup>-8</sup>	8.851 x 10 <sup>-7</sup>
kgm <sup>(1)</sup>	9.807	980.7	9.807 x 10 <sup>7</sup>	---	100	1 x 10 <sup>5</sup>	1,389	7.233	86.8
kgcm <sup>(1)</sup>	0.09807	9.807	9.807 x 10 <sup>5</sup>	0.01	---	1,000	13.89	0.07233	0.868
gcm <sup>(1)</sup>	9.807 x 10 <sup>-5</sup>	0.009807	980.7	0.00001	0.001	---	0.01389	7.233 x 10 <sup>-5</sup>	0.000868
oz-in	0.00706	0.7062	70,620	0.000720	0.07201	72.01	---	0.005283	0.0625
lb-ft	1.356	135.6	1.356 x 10 <sup>7</sup>	0.1383	13.83	13,830	192	---	12
lb-in	0.113	11.30	1.130 x 10 <sup>6</sup>	0.01152	1.152	1,152	16	0.0833	---

Multiply units of "A" by indicated factor to obtain units of "B"

(1) Sometimes written as kpm, kpcm, and pcm, respectively, to denote the force equivalent to the kg and g mass



## USA, CANADA or MEXICO

Danaher Motion  
203A West Rock Road  
Radford, VA 24141 USA  
Phone: 1-540-633-3400  
Fax: 1-540-639-4162  
Email: DMAC@danahermotion.com  
Literature: LitRequest@danahermotion.com

## ASIA

### China

Danaher Motion  
Rm 2205, Scitech Tower  
22 Jianguomen Wai Street  
Beijing, China, 100004  
Phone: +86 10 6515 0260  
Fax: +86 10 6515 0263  
Email: chinainfo@danahermotion.com.cn

### Japan

Danaher Motion Japan  
2F, Sigma Hatchobori Bldg,  
2-7-1 Hatchobori Chuo-ku,  
Tokyo 104-0032 Japan  
Phone: +81-3-6222-1051  
Fax: +81-3-6222-1055  
Email: info@danahermotion.com

## EUROPE

### France

Danaher Motion  
C.P. 80018  
12, Rue Antoine Becquerel - Z.I. Sud  
F-72026 Le Mans Cedex 2  
France  
Phone: +33 (0) 243 50 03 30  
Fax: +33 (0) 243 50 03 39  
Email: sales.france@tollo.com

### Germany

Danaher Motion GmbH  
Wacholderstr. 40-42  
D-40489 Düsseldorf  
Germany  
Phone: +49 (0) 203 9979-0  
Fax: +49 (0) 203 9979-155  
Email: info@danahermotion.net

### Italy

Danaher Motion srl  
Largo Brughetti ZI  
20030 Bovisio Masciago (MI)  
Italy  
Phone: +39 0362 59 42 60  
Fax: +39 0362 59 42 63  
Email: info@danahermotion.it

### Sweden

Danaher Motion  
Box 9053  
SE-29109 Kristianstad  
Sweden  
Phone: +46 (0) 44 24 67 00  
Fax: +46 (0) 44 24 40 85  
Email: helpdesk@tollo.com

### UK

Danaher Motion  
Chartmoor Road,  
Chartwell Business Park  
Leighton Buzzard, Bedfordshire  
LU7 4WG. United Kingdom  
Phone: +44 (0) 1525 243 243  
Fax: +44 (0) 1525 243 244  
Email: uksales@danahermotion.com