



Step Motor Selection Guide

CT Series Step Motors

CTM Maximum Series

CTP Performance Series



Helping you build a better machine, faster.



*Helping you build a better machine, **faster.***

Danaher Motion - Helping you build a better machine, faster

Danaher Corporation combined over 30 industry-leading brands such as Kollmorgen, Thomson, Dover, Pacific Scientific, Portescap, Neff, Seidel and Bautz to establish a customer-focused motion control manufacturing company called Danaher Motion. We offer this powerful set of integrated motion control technologies under the Danaher Motion and Thomson brand names. We are a \$1B+ global motion control leader, unique in our ability to marshal decades of application experience and technical innovation to help you build better machines, faster.

Danaher Motion defines high standards of quality, innovation and technology. We enable improved machine performance and reliability while controlling costs. Our global manufacturing footprint, rapid customization and prototyping capabilities drive quick lead times. Unmatched application experience and design expertise empowers you to commission machines faster.

Consider your options in today's market for a motion control partner. Select Danaher Motion and join a team with 6100 employees, over 60 years of application experience and 2000+ distributor locations around the globe. Danaher Motion serves industries as diverse as semiconductor, aerospace and defense, electric vehicle systems, packaging, printing, medical and robotics. We offer an unparalleled depth and breadth of motion control product solutions through a worldwide service and support infrastructure, field service engineers and support teams available when and where you need them.

The Danaher Business System - Building sustainable competitive advantage into your business

The Danaher Business System (DBS) was established to increase the value we bring to customers. It is a mature and successful set of tools we use daily to continually improve manufacturing operations and product development processes. DBS is based on the principles of Kaizen which continuously and aggressively eliminate waste in every aspect of our business. DBS focuses the entire organization on achieving breakthrough results that create competitive advantages in quality, delivery and performance – advantages that are passed on to you. Through these advantages Danaher Motion is able to provide you faster times to market as well as unsurpassed product selection, service, reliability and productivity.

Local Support Around the Globe



Table of Contents

Introduction.....	4
Construction.....	5
Basic Step Motor Operation.....	6
Model Numbers.....	7
Connection Diagrams & Switching Sequences.....	7
CTP1 - Size 17 Step Motors.....	8 - 9
CTM2/CTP2 - Size 23 Step Motors.....	10 - 11
CTM3/CTP3 - Size 34 Step Motors.....	12 - 13
Motor/Drive System Performance.....	14
24 Volt Speed Torque Curves.....	14
36 Volt Speed Torque Curves.....	15
72 Volt Speed Torque Curves.....	16
340 Volt Speed Torque Curves.....	17
Conversion Factors.....	18

Danaher Motion has combined high performance step motor designs with world wide manufacturing capabilities to create the new CT Series Step Motors.

All CT Series Step Motors incorporate innovative cooling technology (patent pending), high torque magnetic designs, rugged bearings, and high voltage insulation systems. These features provide high torque motors, which support large mechanical loads, and can be used with all drives. In addition, CTM Maximum Series Step Motors use patented enhancing technology to increase efficiency and provide even more torque at all speeds.

Outstanding performance is only part of the CT story. CT Series motors are available in the most popular sizes (17, 23, and 34), and are available in a variety of lengths, windings and shafts.

Custom Motors

Danaher Motion routinely provides motors with many types of modifications. Please contact us with your specific requirements.

Shaft Modifications

A variety of motor output shaft modifications can be supplied. These include special flats and keyways, lengths, diameters, through holes and similar changes which may be needed to allow mounting of leadscrews, timing belts, pulleys or gears.

Electrical Modifications

Motors can be supplied with a number of electrical modifications, including: nonstandard lead lengths, electrical connectors and special windings.



CT Series Step Motors . . . run cooler, produce more torque, and support higher shaft loads than any other step motor.

CTM Series motors incorporate patented enhancing magnets in the stator to provide 25% more torque at all speeds. The increased power output comes from higher efficiency. This allows the use of smaller drives and power supplies. Available in size 23 and size 34 motors.

All CT motors utilize high torque magnetic designs that feature a large rotor diameter, small air gap, high energy rotor magnets and computer controlled windings. This provides maximum torque in the smallest package.

- Lower Energy Usage
- Faster Machines
- Lower System Cost
- More Compact Machines

High Voltage Insulation

Inset molded insulation system encases the stator, eliminating joints and gaps that can fail. Reliability and voltage ratings are increased. CT Series motors can be used with all standard drives, as well as high voltage high performance drives.

- Faster design cycles knowing CT Series motors work with all drives.
- Higher reliability

Cooling Shell (patent pending)

Aluminum shell and aluminum end-caps quickly remove heat from the motor. This allows for higher current and torque ratings, especially when the motor is mounted. CT motors produce the same torque at lower temperatures for longer life.

- Faster, higher throughput machines
- Reduced size
- Longer life

Large Bearing System

To accommodate high thrust loads and high side loading, CT Series motors feature large bearings.

Size 23 & 34 motors have the front bearing retained with a snap ring. And, the rear bearing is mounted in an O-ring to prevent spinout and minimize motor noise.

- Lower machine costs. Loads can be directly mounted on motor shaft eliminating couplings and load support bearings.
- Excellent for leadscrew applications
- Longer life

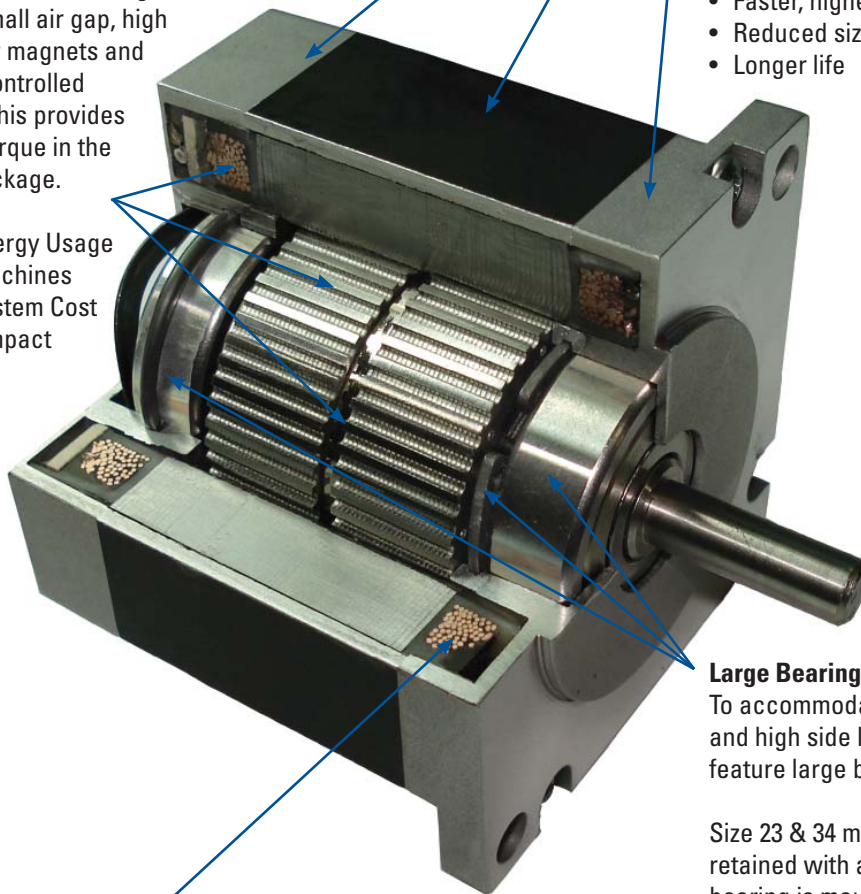

Basic Step Motor Operation

CT Series step motors have two windings (two phases) that are energized with DC current. When the current in one winding is reversed, the motor shaft moves one step, or 1.8°. By reversing the current in each winding the position and speed of the motor is easily and precisely controlled, making these motors extremely useful for many different motion control applications.

For even finer resolution and smoother operation, micro-stepping drives divide each step into many increments by controlling the magnitude of the current in each winding.

The performance of hybrid step motors is highly dependent on the current and voltage supplied by a drive. CT Series step motors are available with a variety of windings so they can be used with drives that have a broad range of voltage and current ratings. Performance curves are included in this catalog for many common motor drive combinations.

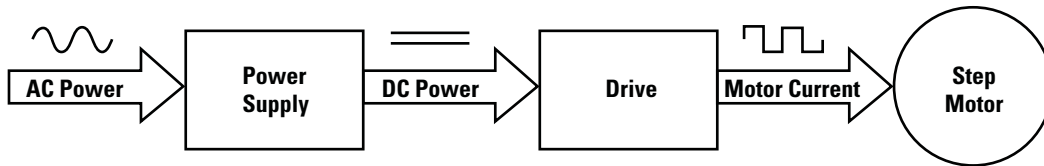

Holding Torque

Because motor performance at speed varies greatly with the drive, holding torque is used to rate hybrid step motors. Holding torque specifies the maximum torque that can be applied to a motor shaft and not cause the shaft to rotate. It is measured with the motor at standstill and energized with rated DC current. Since the motor is energized with pure DC current, holding torque is not dependent on specific drive characteristics.

CTM Enhancing Technology

- Smaller drives = Lower system cost
- More torque = Smaller, faster machines
- Higher efficiency = Lower operating costs

Through the use of enhancing technology, CTM step motors provide the maximum performance available. This patented technology boosts torque an additional 25% across the entire speed range and allows machines to be designed that are smaller and move faster.

Initial system costs are often less with enhanced motors because the additional torque is produced without the need for larger drives or power supplies. The additional output power is produced through higher efficiency. The higher efficiency reduces energy usage by 25% and lowers operating costs.

Enhanced CTM motors use additional magnets inserted between each stator tooth. These magnets block the magnet fields from flowing around the stator teeth. This forces more of the magnetic field to flow through each tooth where it produces torque.

Standard Step Motor

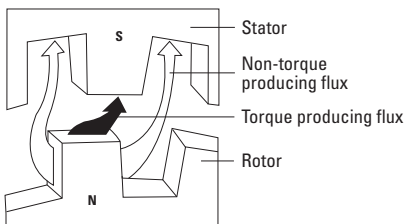

Typical paths of flux transfer in an energized conventional hybrid step motor. Some flux leakage occurs in normal operation.

Enhanced Step Motor

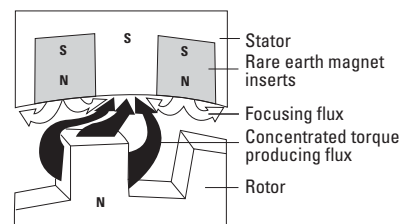

Patented enhancing technology redirects magnetic flux to inhibit leakage and optimize torque production.

CT Series Model Numbers

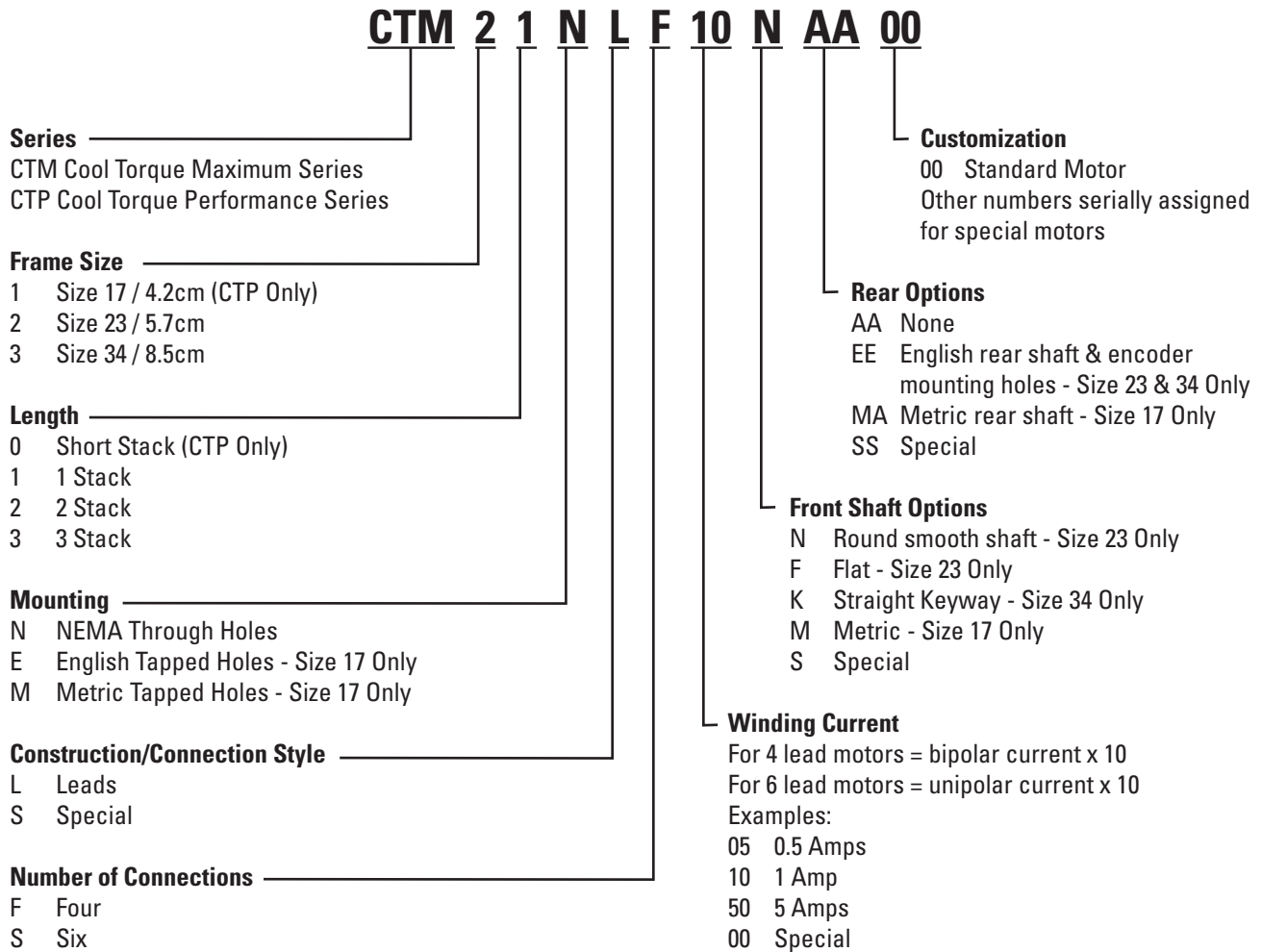

CT Series Connection Diagrams & Switching Sequences

4 Lead Motors

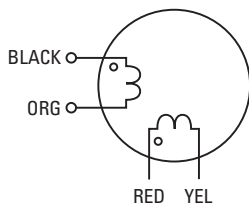

Bipolar Winding - Full Step

Step	BLK	ORG	RED	YEL
1	+	-	+	-
2	-	+	+	-
3	-	+	-	+
4	+	-	-	+
1	+	-	+	-

Direction of rotation as viewed from mounting end of motor.

CW (downward arrow) CCW (upward arrow)

6 Lead Motors

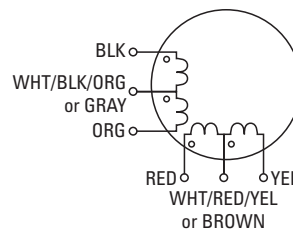

Unipolar Winding - Full Step

Step	BLK	ORG	RED	YEL	WHT/BLK/ORG WHT/RED/YEL
1	-	-	-	-	+
2	-	-	-	-	+
3	-	-	-	-	+
4	-	-	-	-	+
1	-	-	-	-	+

Direction of rotation as viewed from mounting end of motor.

CW (downward arrow) CCW (upward arrow)

CTP1-Size 17

- High torque
- Inch or metric mounting
- RoHS Compliant
- Custom Motors

Phases	2
Full Steps per Revolution	200
Step Angle	1.8°
Step Accuracy	±5%
Operating Temperature	-20°C to +40°C
Insulation Class	Class B, 130°C
Insulation Voltage Rating	80 VDC
Insulation Resistance	100 Megohms
Shaft Load	(20,000 hrs at 1,500 rpm)
Radial	15 lbs (6.8 kg) at shaft center
Axial	6 lbs (2.7 kg) push 15 lbs (6.8) pull

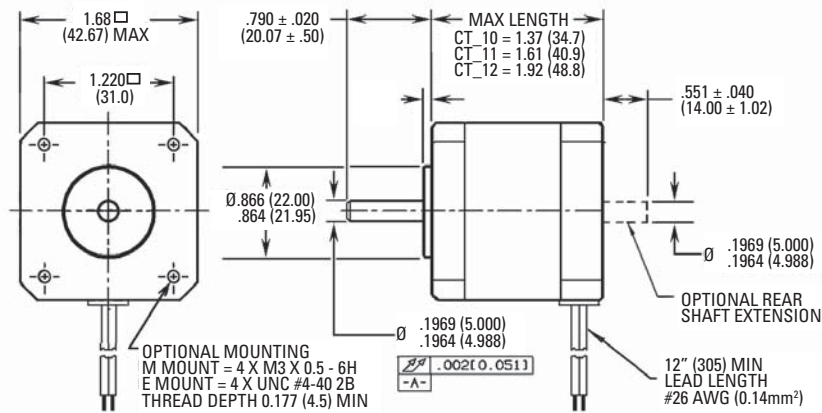

Series	Motor Torque Motor Mounted				Detent Torque		Thermal Resistance Mounted °C/watt	Rotor Inertia		Net Weight	
	Bipolar		Unipolar		Typical			oz-in-S ²	kg-cm ²	lbs	kg
	oz-in	N-m	oz-in	N-m	oz-in	N-m					
CTP10	43	0.30	33	0.23	2	0.014	6.21	0.00051	0.04	0.45	0.20
CTP11	62	0.44	49	0.35	2.5	0.018	5.44	0.00075	0.05	0.57	0.26
CTP12	80	0.56	62	0.44	3	0.021	4.71	0.00106	0.07	0.76	0.34

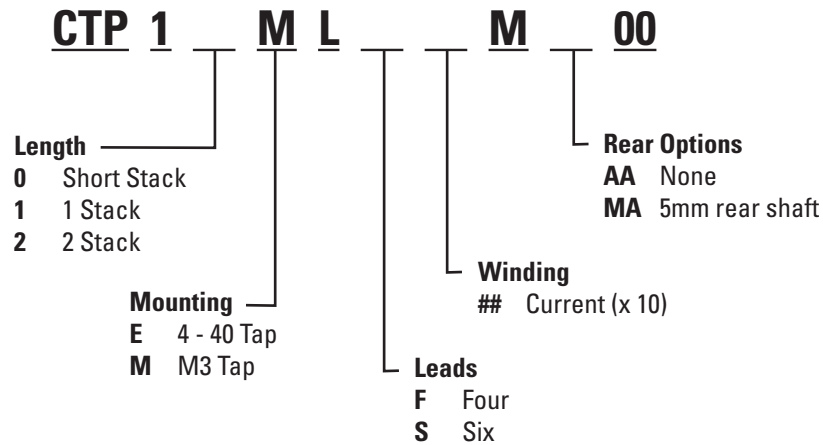

4 Lead Motors - Bipolar Ratings

Size 17	Model Number (basic English mount)	Current amps DC	Voltage VDC	Resistance ohms ±10%	Inductance mH Typical
Short Stack	CTP10ELF16MAA00	1.6	3.4	2.15	3.0
	CTP10ELF10MAA00	1.0	5.2	5.25	7.7
	CTP10ELF06MAA00	0.63	8.1	12.8	18
	CTP10ELF04MAA00	0.40	12.5	30.5	42
1 Stack	CTP11ELF17MAA00	1.7	3.6	2.12	4.2
	CTP11ELF11MAA00	1.1	5.5	5.19	11
	CTP11ELF07MAA00	0.68	8.5	12.5	26
	CTP11ELF04MAA00	0.44	13.4	30.4	60
2 Stack	CTP12ELF26MAA00	2.6	2.8	1.09	1.9
	CTP12ELF16MAA00	1.6	4.3	2.65	4.9
	CTP12ELF10MAA00	1.0	6.6	6.51	12
	CTP12ELF07MAA00	0.65	10.2	15.7	30

6 Lead Motors - Unipolar Ratings

Size 17	Model Number (basic English mount)	Current amps DC	Voltage VDC	Resistance ohms ±10%	Inductance mH Typical
Short Stack	CTP10ELS12MAA00	1.2	4.2	3.38	2.40
	CTP10ELS08MAA00	0.80	6.4	8.04	5.5
	CTP10ELS05MAA00	0.50	9.9	19.4	13
	CTP10ELS03MAA00	0.33	15.6	47.1	31
1 Stack	CTP11ELS13MAA00	1.3	4.4	3.31	3.4
	CTP11ELS09MAA00	0.85	6.8	8.02	8.0
	CTP11ELS06MAA00	0.55	10.4	18.9	18
	CTP11ELS03MAA00	0.35	16.8	48.1	47
2 Stack	CTP12ELS20MAA00	2.0	3.5	1.70	1.6
	CTP12ELS13MAA00	1.3	5.3	4.13	3.9
	CTP12ELS08MAA00	0.82	8.2	10.1	9.2
	CTP12ELS05MAA00	0.53	12.6	23.8	21

Rated current is per phase, with the motor mounted, and winding temperature rise $\Delta T = 90^{\circ}\text{C}$. Resistance is with winding at 20°C .

CTM2/CTP2-Size 23

- CTM Enhanced Series – Maximum Torque and Efficiency
- CTP High Torque Performance Series
- Heavy duty bearings – excellent for use with leadscrews
- High voltage insulation system
- RoHS Compliant
- Custom Motors



Phases	2
Full Steps per Revolution	200
Step Angle	1.8°
Step Accuracy	±3%
Operating Temperature	-20°C to +40°C
Insulation Class	Class B, 130°C
Insulation Voltage Rating	340 VDC
Insulation Resistance	100 Megohms
Shaft Load	(20,000 hrs at 1,500 rpm)
Radial	20 lbs. (9 kg) at shaft center
Axial	50 lbs. (23 kg) both directions

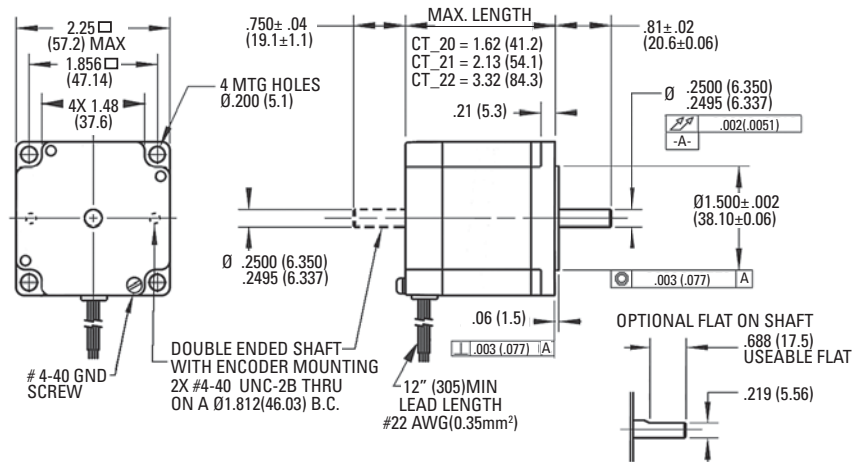

Series	Motor Torque Motor Mounted				Detent Torque		Thermal Resistance Mounted °C/watt	Rotor Inertia		Net Weight	
	Bipolar		Unipolar		Typical			oz-in-S ²	kg-cm ²	lbs	kg
	oz-in	N-m	oz-in	N-m	oz-in	N-m					
CTM21	260	1.84	200	1.41	13	0.09	3.57	0.0035	0.24	1.5	0.68
CTM22	470	3.32	360	2.54	22	0.16	2.62	0.0068	0.48	2.5	1.13
CTP20	100	0.71	75	0.53	5	0.04	3.99	0.0026	0.19	1.0	0.45
CTP21	200	1.41	160	1.13	8	0.06	3.57	0.0035	0.24	1.4	0.65
CTP22	360	2.54	285	2.01	12	0.08	2.62	0.0068	0.48	2.4	1.10

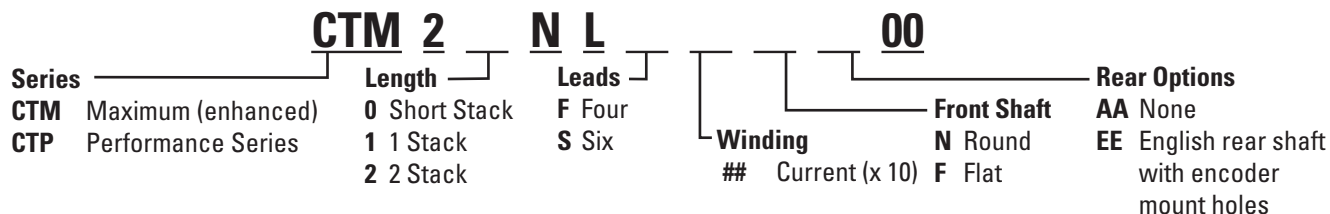

4 Lead Motors - Bipolar Ratings

Size 23	Max Torque Series		Performance Series		Current amps DC	Resistance ohms ±10%
	Model Number (base motor)	Inductance mH Typical	Model Number (base motor)	Inductance mH Typical		
Short Stack			CTP20NLF38NAA00	1.3	3.8	0.58
			CTP20NLF27NAA00	2.5	2.7	1.11
			CTP20NLF17NAA00	7.1	1.7	2.87
			CTP20NLF11NAA00	17	1.1	6.98
			CTP20NLF07NAA00	41	0.68	17.1
			CTP20NLF04NAA00	89	0.45	40.6
1 Stack	CTM21NLF56NAA00	0.78	CTP21NLF56NAA00	1.1	5.6	0.31
	CTM21NLF39NAA00	1.6	CTP21NLF39NAA00	2.2	3.9	0.60
	CTM21NLF25NAA00	4.2	CTP21NLF25NAA00	5.8	2.5	1.48
	CTM21NLF15NAA00	12	CTP21NLF15NAA00	16	1.5	3.86
	CTM21NLF10NAA00	28	CTP21NLF10NAA00	38	1.0	9.40
	CTM21NLF04NAA00	123	CTP21NLF04NAA00	170	0.45	44.0
2 Stack	CTM22NLF69NAA00	0.81	CTP22NLF69NAA00	1.2	6.9	0.28
	CTM22NLF50NAA00	1.6	CTP22NLF50NAA00	2.2	5.0	0.52
	CTM22NLF31NAA00	4.3	CTP22NLF31NAA00	6.1	3.1	1.31
	CTM22NLF19NAA00	11	CTP22NLF19NAA00	16	1.9	3.25
	CTM22NLF12NAA00	29	CTP22NLF12NAA00	41	1.2	8.40
	CTM22NLF06NAA00	108	CTP22NLF06NAA00	150	0.6	32.2

6 Lead Motors - Unipolar Ratings

Size 23	Max Torque Series		Performance Series		Current amps DC	Resistance ohms ±10%
	Model Number (base motor)	Inductance mH Typical	Model Number (base motor)	Inductance mH Typical		
Short Stack			CTP20NLS34NAA00	0.83	3.4	0.73
			CTP20NLS21NAA00	2.2	2.1	1.83
			CTP20NLS13NAA00	5.2	1.3	4.39
			CTP20NLS09NAA00	12	0.87	10.5
1 Stack	CTM21NLS48NAA00	0.54	CTP21NLS48NAA00	0.74	4.8	0.41
	CTM21NLS31NAA00	1.4	CTP21NLS31NAA00	1.9	3.1	0.97
	CTM21NLS19NAA00	3.7	CTP21NLS19NAA00	5.0	1.9	2.44
	CTM21NLS12NAA00	8.6	CTP21NLS12NAA00	12	1.2	5.89
2 Stack	CTM22NLS49NAA00	0.81	CTP22NLS49NAA00	1.2	4.9	0.53
	CTM22NLS31NAA00	2.1	CTP22NLS31NAA00	3.0	3.1	1.30
	CTM22NLS19NAA00	5.9	CTP22NLS19NAA00	8.3	1.9	3.39
	CTM22NLS12NAA00	14	CTP22NLS12NAA00	20	1.2	8.26

Rated current is per phase, with the motor mounted, and winding temperature rise $\Delta T = 90^{\circ}\text{C}$. Resistance is with winding at 20°C .

CTM3/CTP3-Size 34

- CTM Enhanced Series – Maximum Torque and Efficiency
- CTP High Torque Performance Series
- Captured front bearing – excellent for use with leadscrews
- High voltage insulation system
- RoHS Compliant
- Custom Motors

Phases	2
Full Steps per Revolution	200
Step Angle	1.8°
Step Accuracy	±3%
Operating Temperature	-20°C to ±40°C
Insulation Class	Class B, 130°C
Insulation Voltage Rating	340 VDC
Insulation Resistance	100 Megohms
Shaft Load	(20,000 hrs at 1,500 rpm)
Radial	65 lbs. (29 kg) at shaft center
Axial	100 lbs. (45 kg) both directions

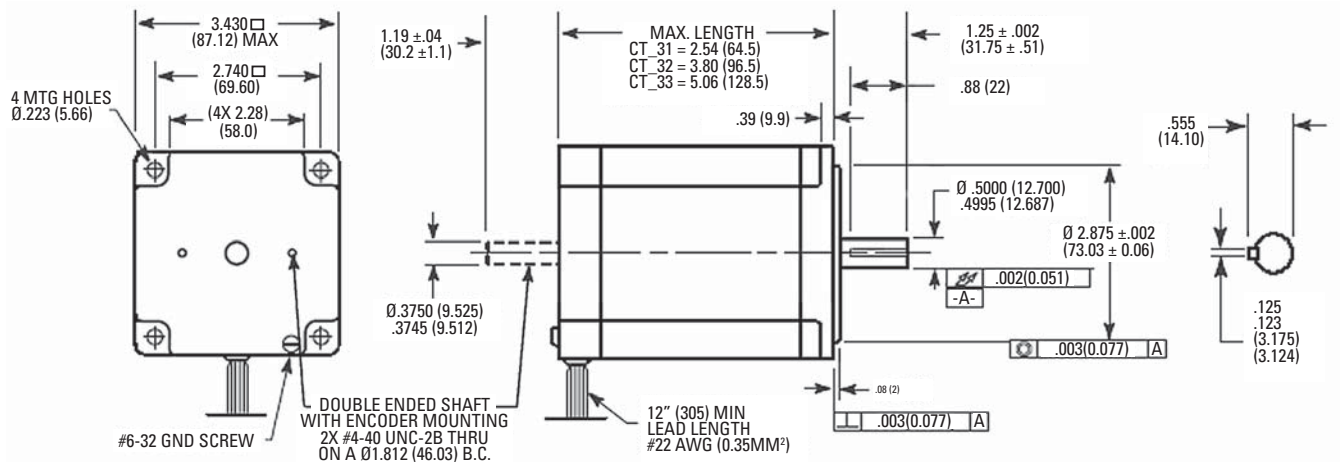

Series	Motor Torque Motor Mounted				Detent Torque		Thermal Resistance Mounted °C/watt	Rotor Inertia		Net Weight	
	Bipolar		Unipolar		Typical			oz-in-S ²	kg-cm ²	lbs	kg
	oz-in	N-m	oz-in	N-m	oz-in	N-m					
CTM31	690	4.9	550	3.9	30	0.21	2.02	0.0185	1.31	4.1	1.9
CTM32	1350	9.5	1070	7.6	41	0.29	1.55	0.0370	2.61	6.6	3.0
CTM33	1930	13.6	1500	10.6	52	0.37	1.36	0.0555	3.92	9.3	4.2
CTP31	565	4.0	460	3.3	22	0.16	2.02	0.0185	1.31	4.0	1.8
CTP32	1100	7.8	890	6.3	30	0.21	1.55	0.0370	2.61	6.5	3.0
CTP33	1570	11	1250	8.8	38	0.27	1.36	0.0555	3.92	9.1	4.1

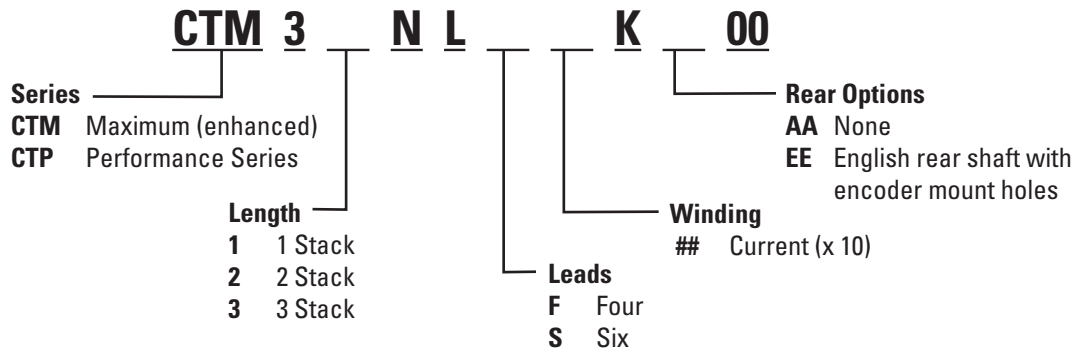

4 Lead Motors - Bipolar Ratings

Size 34	Max Torque Series		Performance Series		Current amps DC	Resistance ohms ±10%
	Model Number (base motor)	Inductance mH Typical	Model Number (base motor)	Inductance mH Typical		
Short Stack	CTM31NLF99KAA00	0.87	CTP31NLF99KAA00	1.2	9.90	0.19
	CTM31NLF72KAA00	1.7	CTP31NLF72KAA00	2.3	7.2	0.34
	CTM31NLF45KAA00	4.3	CTP31NLF45KAA00	5.8	4.5	0.79
	CTM31NLF28KAA00	12	CTP31NLF28KAA00	16	2.8	2.02
	CTM31NLF09KAA00	112	CTP31NLF09KAA00	150	0.9	19.5
1 Stack	CTM32NLF99KAA00	1.4	CTP32NLF99KAA00	1.8	9.9	0.23
	CTM32NLF73KAA00	2.7	CTP32NLF73KAA00	3.4	7.3	0.41
	CTM32NLF46KAA00	7.1	CTP32NLF46KAA00	9.1	4.6	1.01
	CTM32NLF28KAA00	19	CTP32NLF28KAA00	24	2.8	2.53
	CTM32NLF11KAA00	120	CTP32NLF11KAA00	150	1.1	16.1
2 Stack	CTM33NLF99KAA00	1.6	CTP33NLF99KAA00	2.0	9.9	0.24
	CTM33NLF75KAA00	3.2	CTP33NLF75KAA00	4.0	7.5	0.45
	CTM33NLF47KAA00	8.2	CTP33NLF47KAA00	10	4.7	1.08
	CTM33NLF29KAA00	22	CTP33NLF29KAA00	27	2.9	2.73
	CTM33NLF13KAA00	111	CTP33NLF13KAA00	140	1.3	13.8

6 Lead Motors - Unipolar Ratings

Size 34	Max Torque Series		Performance Series		Current amps DC	Resistance ohms ±10%
	Model Number (base motor)	Inductance mH Typical	Model Number (base motor)	Inductance mH Typical		
Short Stack	CTM31NLS56KAA00	1.4	CTP31NLS56KAA00	1.9	5.6	0.53
	CTM31NLS35KAA00	3.7	CTP31NLS35KAA00	4.9	3.5	1.29
	CTM31NLS22KAA00	9.4	CTP31NLS22KAA00	13	2.2	3.21
1 Stack	CTM32NLS58KAA00	2.2	CTP32NLS58KAA00	2.8	5.8	0.65
	CTM32NLS36KAA00	6.0	CTP32NLS36KAA00	7.6	3.6	1.63
	CTM32NLS23KAA00	15	CTP32NLS23KAA00	19	2.3	4.00
2 Stack	CTM33NLS59KAA00	2.6	CTP33NLS59KAA00	3.2	5.9	0.70
	CTM33NLS37KAA00	6.7	CTP33NLS37KAA00	8.4	3.7	1.74
	CTM33NLS23KAA00	17	CTP33NLS23KAA00	21	2.3	4.31

Rated current is per phase, with the motor mounted, and winding temperature rise $\Delta T = 90^{\circ}\text{C}$. Resistance is with winding at 20°C .

Motor/Drive System Performance

As the applied voltage and/or current to the motor is changed, motor performance is altered. Caution must be exercised when increasing drive current or supply voltage as both will result in increased motor heating.

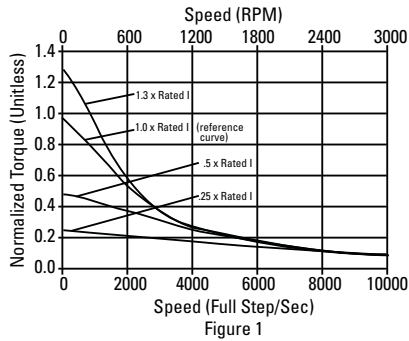

Figure 1 shows the performance of a motor with different drive current settings and the same supply voltage. Note that low speed running torque varies considerably with changes in drive current setting, but high speed performance is not appreciably affected.

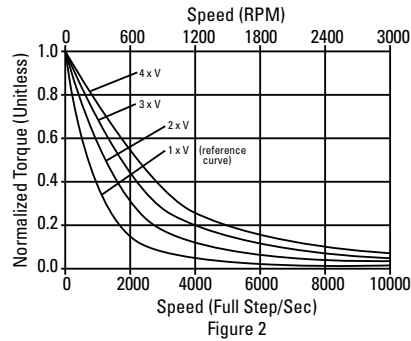
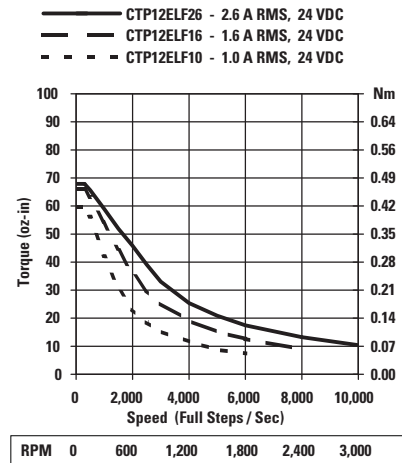
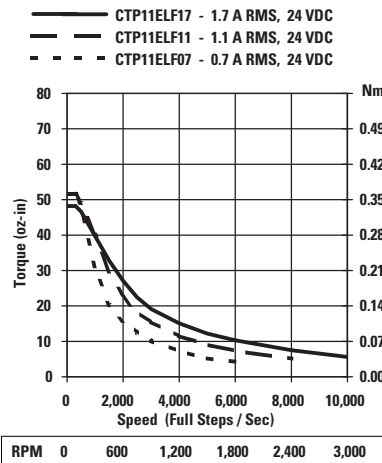
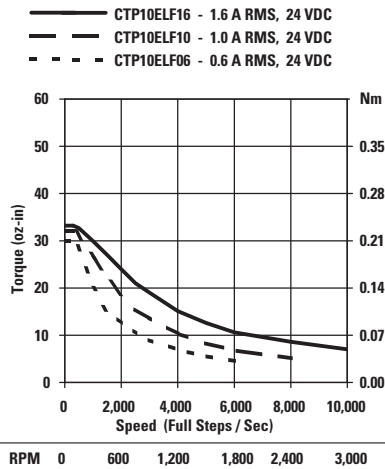

Figure 2 shows the performance of a motor with different supply voltages and the same drive current setting. Note that low speed running torque is not appreciably affected by supply voltage differences, but high speed performance varies considerably with changes in supply voltage.

CT Motor Performance with 24 VDC Bipolar Drives

Size 17 Motors



Size 23 Motors

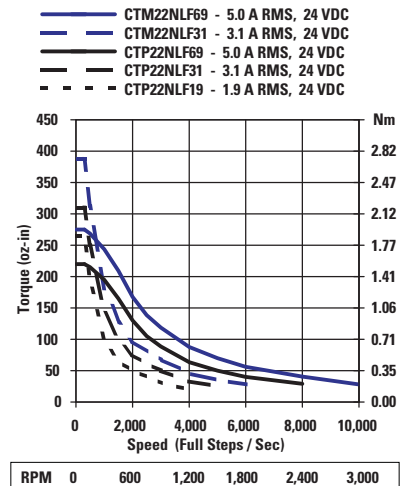
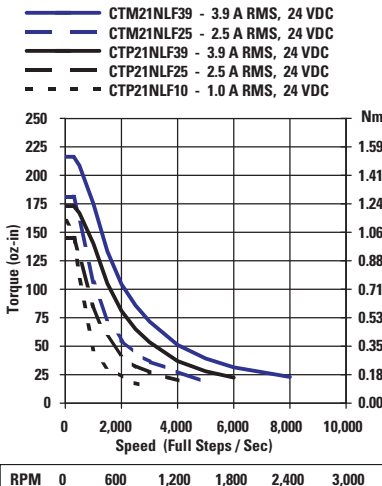
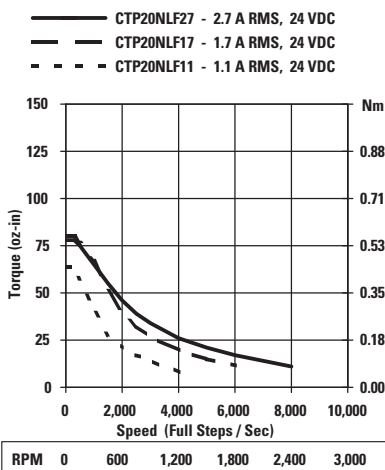

CT Motor Performance with 36 VDC Bipolar Drives

Size 17 Motors

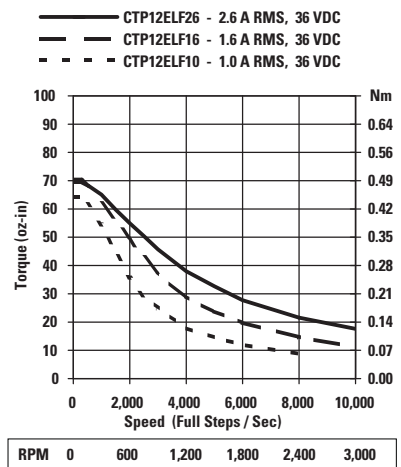
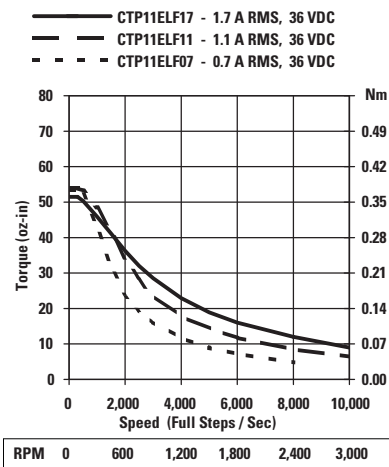
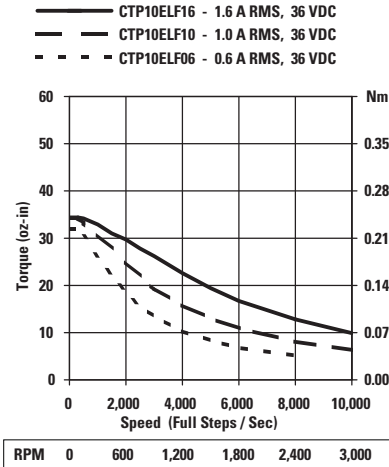

Size 23 Motors

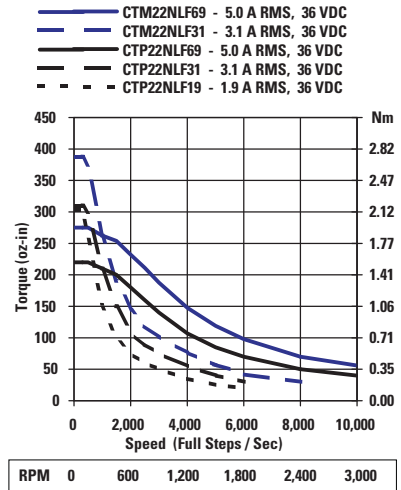
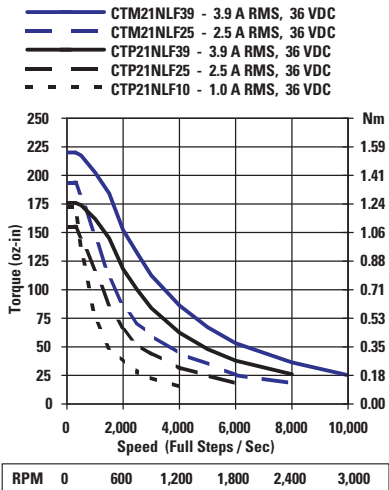
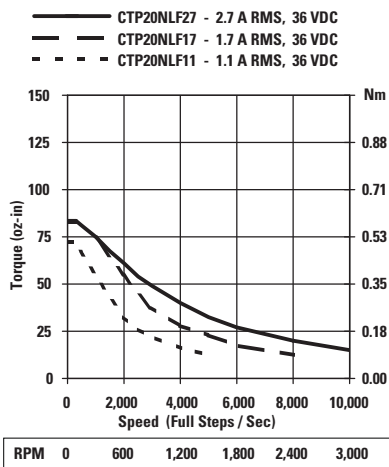

Size 34 Motors

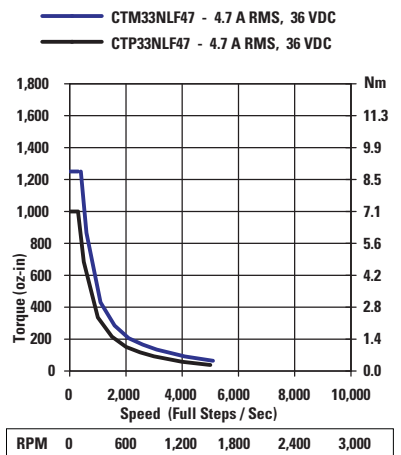
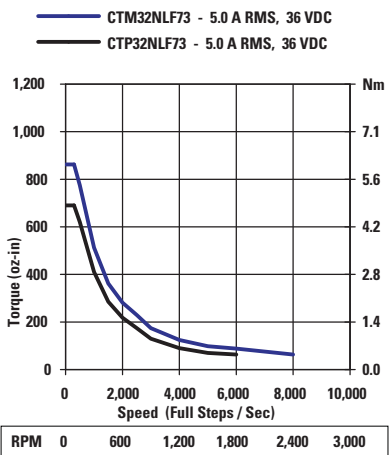
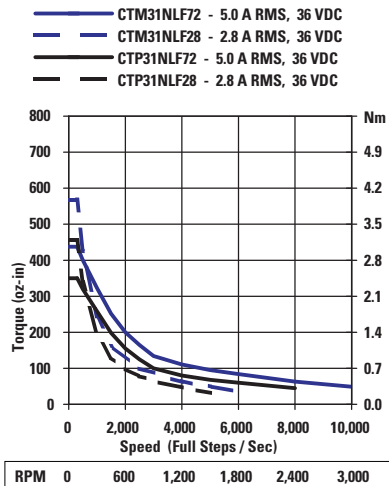

P7000 DC Modular Step Motor Drive

P70530-SDN Step & Direction Version
P70530-PNN Programmable Version

- Open Loop Stall Detection
- Smooth Performance with Advanced Current Control
- Input voltages from 20 to 75 VDC
- Continuous Current to 5 Amps RMS - Bipolar
- Compact: 1.14 inch (29mm) wide, 4.4 inch (111mm) tall



CT Motor Performance with 72 VDC Bipolar Drives

Size 23 Motors

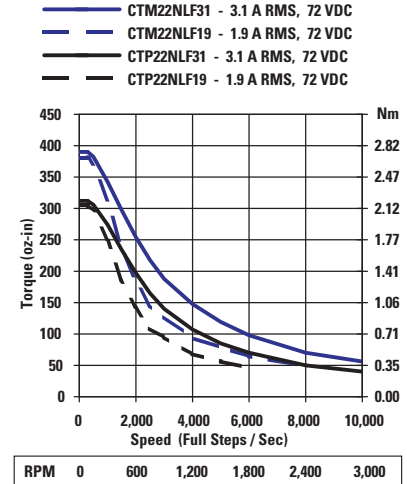
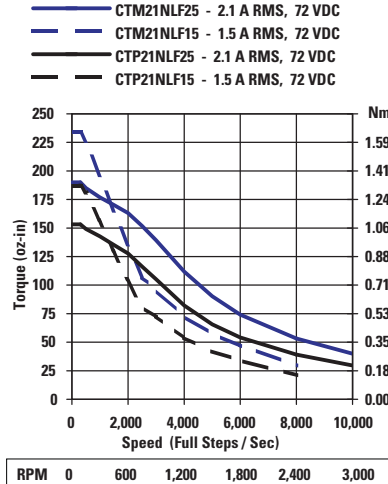
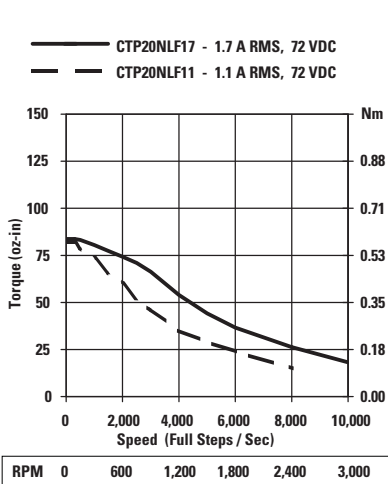

Size 34 Motors

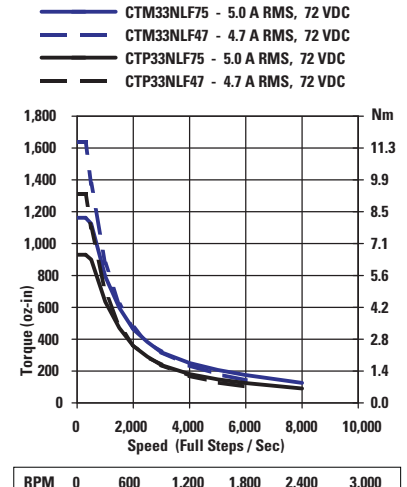
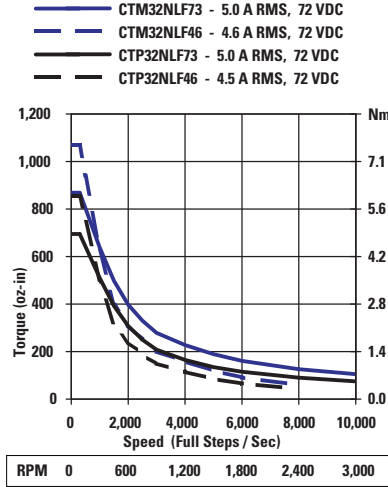
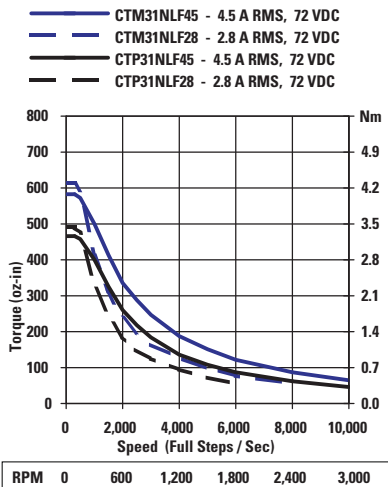

P7000 AC Packaged Step Motor Drive

P70360-SDN Step & Direction Version
P70360-PNN Programmable Version

- Integral Power Supply Accepts 120 or 240 VAC Input
- Open Loop Stall Detection
- Smooth Operation with Advanced Current Control
- Maximum Performance from 320 VDC BUS
- Continuous Current to 2.5 Amps RMS - Bipolar
- Compact: 2.06 inch (52mm) wide, 5.2 inch (132mm) tall



CT Motor Performance with P7000AC Drives (320 VDC)

Size 23 Motors

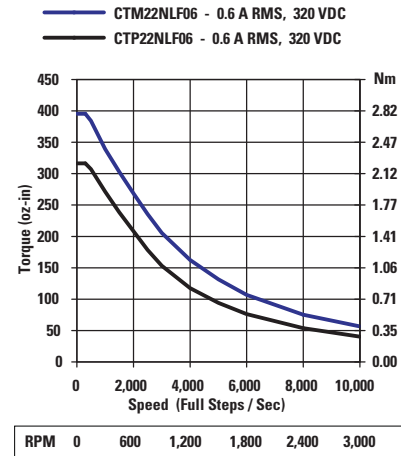
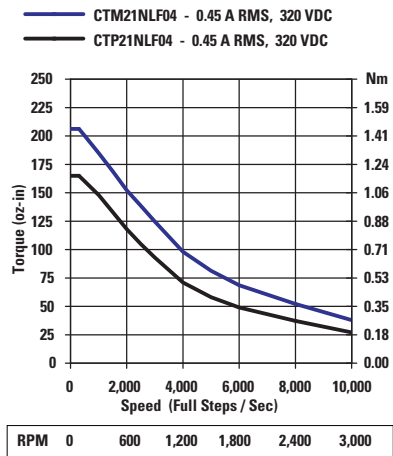

Size 34 Motors

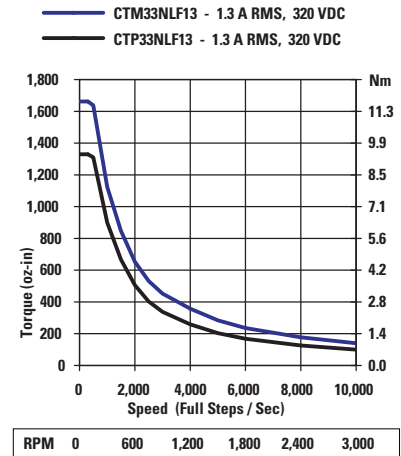
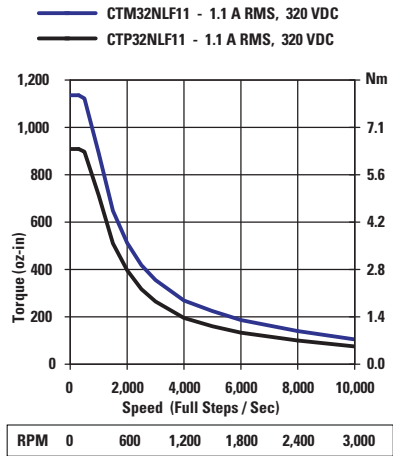
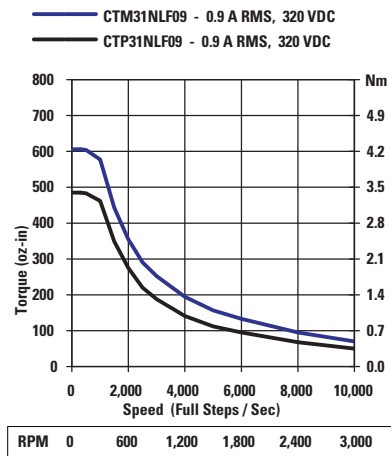

Conversion Factors

Length

A \ B	mm	cm	m	inch	feet
mm	---	0.1	0.001	0.03937	0.003281
cm	10	---	0.01	0.3937	0.03281
m	1000	100	---	39.37	3.281
inch	25.4	2.54	0.0254	---	0.08333
feet	304.8	30.48	0.3048	12	---

Multiply units of "A" by indicated factor to obtain units of "B"

Force

A \ B	g	kg	oz	lb	Newton
g	---	0.001	0.03527	0.002205	0.0098
kg	1000	---	35.27	2.205	9.807
oz	28.35	0.02835	---	0.0625	0.278
lb	453.6	0.4536	16	---	4.448
Newton	102	0.102	3.597	0.2248	---

Multiply units of "A" by indicated factor to obtain units of "B"

Inertia

A \ B	kgm ²	kgcm ²	gcm ²	oz-in ²	oz-in-sec ²	lb-in ²	lb-in-sec ²	lb-ft ²	lb-ft-sec ² (slug ft ²)
kgm ²	---	10,000	1 x 10 ⁷	54,670	141.6	3,418	8.851	23.73	0.7376
kgcm ²	0.0001	---	1,000	5.457	0.01416	0.3418	0.000885	0.002373	7.376 x 10 ⁻⁵
gcm ²	1.00 x 10 ⁻⁷	0.001	---	0.005467	1.416 x 10 ⁻⁵	0.000342	8.851 x 10 ⁻⁷	2.373 x 10 ⁻⁶	7.376
oz-in ²	1.829 x 10 ⁻⁵	0.1829	182.9	---	0.00259	0.0625	0.000162	0.000434	1.349 x 10 ⁻⁵
oz-in-sec ²	0.00706	70.61	70,610	386.1	---	24.13	0.0625	0.1676	0.00521
lb-in ²	0.000293	2.926	2,926	0.16	0.04144	---	0.00259	0.006944	0.000216
lb-in-sec ²	0.113	1,130	1.13 x 10 ⁶	6,177	16	386.1	---	2.681	0.0833
lb-ft ²	0.04214	421.4	4.214 x 10 ⁵	2,304	5.968	144	0.373	---	0.0318
lb-ft-sec ² (slug ft ²)	1.356	13,560	1.356 x 10 ⁷	74,130	192	4.633 x 10 ⁵	12	32.17	---

Multiply units of "A" by indicated factor to obtain units of "B"

Torque

A \ B	Nm	Ncm	dyn cm	kgm ⁽¹⁾	kgcm ⁽¹⁾	gcm ⁽¹⁾	oz-in	lb-ft	lb-in
Nm	---	100	1 x 10 ⁷	0.102	10.20	10,200	141.6	0.7376	8.851
Ncm	0.01	---	1 x 10 ⁵	0.00102	0.102	102	1.416	0.007376	0.08851
dyn cm	1 x 10 ⁻⁷	1 x 10 ⁻⁵	---	1.02 x 10 ⁻⁸	1.02 x 10 ⁻⁶	0.00102	1.416 x 10 ⁻⁵	7.376 x 10 ⁻⁸	8.851 x 10 ⁻⁷
kgm ⁽¹⁾	9.807	980.7	9.807 x 10 ⁷	---	100	1 x 10 ⁵	1,389	7.233	86.8
kgcm ⁽¹⁾	0.09807	9.807	9.807 x 10 ⁵	0.01	---	1,000	13.89	0.07233	0.868
gcm ⁽¹⁾	9.807 x 10 ⁻⁵	0.009807	980.7	0.00001	0.001	---	0.01389	7.233 x 10 ⁻⁵	0.000868
oz-in	0.00706	0.7062	70,620	0.000720	0.07201	72.01	---	0.005283	0.0625
lb-ft	1.356	135.6	1.356 x 10 ⁷	0.1383	13.83	13,830	192	---	12
lb-in	0.113	11.30	1.130 x 10 ⁶	0.01152	1.152	1,152	16	0.0833	---

Multiply units of "A" by indicated factor to obtain units of "B"

(1) Sometimes written as kpm, kpcm, and pcm, respectively, to denote the force equivalent to the kg and g mass

USA, Canada and Mexico

Danaher Motion
203A West Rock Road
Radford, VA 24141 USA
Phone: 1-540-633-3400
Fax: 1-540-639-4162
E-mail: DMAC@danahermotion.com

United Kingdom

Danaher Motion
Chartmoor Road, Chartwell Business Park
Leighton Buzzard, Bedfordshire
LU7 4WG; United Kingdom
Phone: +44 (0)1525 243 243
Fax: +44 (0)1525 243 244
E-mail: sales.uk@danahermotion.com

Germany

Danaher Motion GmbH
Sales Office North
Wacholderstr. 40-42
40489 Düsseldorf
Germany
Phone: +49 (0) 203 9979 214
Fax: +49 (0) 203 9979 3214
E-mail: iris.tolusch@danahermotion.com

Danaher Motion GmbH
Sales Office South West
Brückenfeldstraße 26/1
75015 Bretten
Germany
Phone: +49 (0) 7252 96462 10
Fax: +49 (0) 7252 96462 69
E-mail: kerstin.mueller@danahermotion.com

Danaher Motion GmbH
Sales Office South East
Kiesgräble 7
89129 Langenau
Germany
Phone: +49 (0) 7471 62 23 23
Fax: +49 (0) 7471 62 23 26
E-mail: ursula.koschak@danahermotion.com

France

Danaher Motion
C.P 80018
12, Rue Antoine Becquerel – Z.I. Sud
72026 Le Mans Cedex 2
France
Phone: +33 (0) 243 50 03 30
Fax: +33 (0) 243 50 03 39
E-mail: sales.france@danahermotion.com

Italy

Danaher Motion srl
Largo Brughetti
20030 Bovisio Masciago
Italy
Phone: +39 0362 594260
Fax: +39 0362 594263
E-mail: info@danahermotion.it

Sweden

Danaher Motion
Box 9053
291 09 Kristianstad
Sweden
Phone: +46 (0) 44-24 67 00
Fax: +46 (0) 44-24 40 85
E-mail: sales.scandinavia@danahermotion.com

Switzerland

Danaher Motion SA
La Pierreire 2
1029 Villars-Ste-Croix
Switzerland
Phone: +41 (0) 21 631 33 33
Fax: +41 (0) 21 636 05 09
E-mail: info@danaher-motion.ch

China

Danaher Motion
Rm 2205, Scitech Tower
22 Jianguomen Wai Street
Beijing, China, 100004
Phone: +86 10 6515 0260
Fax: +86 10 6515 0263
E-mail: chinainfo@danahermotion.com.cn

Japan

Danaher Motion Japan
2F, Tokyu Reit Hatchobori Bldg,
2-7-1 Hatchobori Chuo-ku,
Tokyo 104-0032 Japan
Phone: +81-3-6222-1051
Fax: +81-3-6222-1055
E-mail: info@danahermotion.co.jp

Asia Pacific

Danaher Motion (HK) Ltd
Unit A, 16 Floor, 169 Electric Road
Manulife Tower, North Point
Hong Kong
Phone: +852 2503 6581
Fax: +852 2571 8585
E-mail: victor.lim@danahermotion.com