



YOUR PARTNER  
IN BLOWER  
TECHNOLOGY



index\_indice\_índice

[fpz.com](http://fpz.com)

The Company - <i>L'azienda</i> - La sociedad	04
Applications - <i>Applicazioni</i> - Aplicaciones	05
Operating Principle - <i>Principio Operativo</i> - Principio operativo	06
Blower and Motor mountings - <i>Soffiante e montaggio motore</i> - Soplantes y Montaje Motor	07
Configurations - <i>Configurazioni</i> - Configuraciones	08
FPZ Green	10
<i>SIDE CHANNEL BLOWERS</i>	
Technical characteristics - <i>Caratteristiche tecniche</i> - Características Técnicas	14
Compression - <i>Compressione</i> - Compresión 50 Hz	16
Suction - <i>Aspirazione</i> - Aspiración 50 Hz	18
Compression - <i>Compressione</i> - Compresión 60 Hz	20
Suction - <i>Aspirazione</i> - Aspiración 60 Hz	22
Overall dimensions - <i>Ingombri</i> - Dimensiones	26
Accessories - <i>Accessori</i> - Accesorios	32
Reversing valves - <i>Valvole di inversione</i> - Válvulas de inversión	44
Special machines - <i>Macchine speciali</i> - Máquinas especiales	46
ATEX Accessories - <i>Accessori ATEX</i> - Accesorios ATEX	52
Certificates - <i>Certificati</i> - Certificados	55



## The Company

FPZ SpA is an Italian multinational company that manufactures **Side Channel Blowers** to move air, technical gases, methane and biogas in compression and aspiration systems. The company operates on the international market with 8 subsidiaries around the world and a global network of agents and distributors in more than 70 countries. FPZ's mission is to offer a wide range of blowers and accessories that can be used in several industrial sectors and to ensure excellent standards of reliability and on-time deliveries. The two key concepts at FPZ are **customer service and customisation of products**. The company combines a before and after-sales service that is customer-centred and a flexible manufacturing process that meets the needs of the different markets. The goal of FPZ can be summarised in the expression "**Blower Technology**": to develop and guarantee technically advanced machines by applying the lean manufacturing method, which ensures defect-free, top-quality products and punctual services.



## La empresa

FPZ Spa es una multinacional italiana productora de **Soplantes de canal lateral** para el tratamiento sea en compresión que en vacío de aire, gases técnicos, metano y biogás. La empresa está presente en el mercado internacional con 8 filiales en todo el mundo y una red de agentes y distribuidores en más de 70 países. FPZ produce y comercializa una amplia gama de soplantes y accesorios destinados a una gran variedad de sectores industriales, garantizando los máximos estándares de calidad y fiabilidad aún en los plazos de entrega. Los dos conceptos en los que se basa FPZ son: **servicio al cliente y personalización del producto**.

La empresa combina un servicio de atención al cliente antes y post venta y una flexibilidad de producción capaz de satisfacer en detalle las necesidades funcionales del cliente. La tecnología de los soplantes de FPZ Spa permite desarrollar máquinas técnicamente avanzadas producidas con el método "Lean Manufacturing" (producción sin desperdicios) que garantiza la ausencia de defectos, una mejorada calidad del producto y puntualidad de entrega.



## L'azienda

FPZ Spa è una multinazionale italiana produttrice di **Soffianti a Canale Laterale** per il trattamento in compressione e aspirazione di aria, gas tecnici, metano e biogas. L'azienda è presente sul mercato internazionale con 8 filiali nel mondo ed una rete globale di agenti e distributori in più di 70 paesi. La missione di FPZ è quella di offrire una vasta gamma di soffianti e accessori correlati, applicabili ai più differenti settori industriali garantendo un livello di eccellenza in termini di affidabilità e rispetto dei tempi di consegna. I due concetti chiave nelle attività di FPZ sono: **assistenza al cliente e personalizzazione di prodotto**. L'azienda abbina un servizio di assistenza al cliente prima e dopo la vendita ed una flessibilità produttiva in grado di rispondere alle esigenze dei mercati applicativi. L'obiettivo di FPZ Spa è racchiuso nel pay-off "**Blower Technology**": sviluppare e garantire macchine tecnicamente avanzate prodotte secondo il metodo di "Lean Manufacturing" che assicura assenza di difetti, qualità di prodotto e puntualità nel servizio offerto.

## Applications

Side Channel Blowers have many **applications**: from heavy industry to chemical and environmental sectors. Side channel blowers are used in operations such as packaging and packing, material lifting and handling, dust and fume extraction, water purification and treatment, subsurface remediation.

This is possible thanks to the special technical features of these blowers:

- Maintenance-free
- No contact among parts
- Low noise level
- Quiet in use
- No pulsation and no fluid contamination
- Compact in size

A side channel blower can be used in the following sectors:

- Tiles
- Cleaning
- Energy
- Glass
- Medical
- Packaging
- Textile
- Wood
- Chemical-Pharmaceutical
- Electronic
- Food and Beverages
- Graphics
- Metal and Foundry
- Plastics
- Water and Environment



## Applicazioni

Molti i **campi applicativi** che si servono di Soffianti a Canale Laterale: dall'industria pesante al settore chimico ed ambientale. Le soffianti a canale laterale vengono utilizzate in operazioni quali: imballaggio e confezionamento, sollevamento e movimentazione materiali, aspirazione polveri e fumi, depurazione e trattamento delle acque, bonifica del sottosuolo.

Questo è possibile, grazie alle sue peculiari caratteristiche tecniche quali:

- Nessuna manutenzione
- Assenza di contatto tra le parti
- Ridotta rumorosità
- Funzionamento silenzioso
- Nessuna pulsazione e contaminazione del fluido
- Ingombri ridotti

La soffiante a canale laterale trova impiego nei seguenti settori applicativi:

- Ceramica
- Pulizie
- Energetico
- Vetro
- Medico
- Imballaggio
- Tessile
- Legno
- Chimico-Farmaceutico
- Elettronico
- Alimentari e bevande
- Grafica
- Metallurgica e fonderie
- Plastica
- Idrico & Ambientale

## Aplicaciones

Los Soplantes de Canal Lateral se utilizan en muchos **sectores industriales**: desde la industria pesada al sector químico y ambiental. Los Soplantes de Canal Lateral se utilizan en operaciones tales como el envasado y el embalaje, manipulación de cargas, aspiración de polvos y humos, purificación y tratamiento de aguas, remediación del subsuelo, etc.

Esto es posible, gracias a características técnicas particulares, tales como:

- Escaso mantenimiento
- Ausencia de contacto entre las partes
- Bajo nivel de ruido
- Funcionamiento silencioso
- Sin pulsaciones y sin contaminación de fluidos (no lubricantes)
- Dimensiones reducidas

Los Soplantes de Canal Lateral se utilizan principalmente en los siguientes sectores:

- Cerámica
- Limpieza
- Energía
- Vidrio
- Médico
- Embalaje
- Textil
- Maderero
- Químico - Farmacéutico
- Electrónico
- Alimenticio (comidas y bebidas)
- Gráfico
- Metalúrgico
- Plásticos
- Agua y Medio Ambiente

# SIDE CHANNEL BLOWERS

## Operating principle

A Side Channel Blower is a device used to move air and increase pressure thanks to a rotating impeller within a toroidal channel, so there is a progressive increase of energy.

The term "**side channel**" comes from the peripheral position of the toroidal channel compared to the impeller shaft.

## Principio operativo

La Soffiante a Canale Laterale è un dispositivo utilizzato per muovere l'aria ed aumentarne la pressione grazie ad una girante posta in rotazione all'interno di un canale toroidale, con un conseguente e progressivo incremento di energia.

Il termine "**canale laterale**" deriva dalla posizione periferica del canale toroidale rispetto all'asse della girante.

## Principio de funcionamiento

Un Soplante de Canal Lateral es un dispositivo que se utiliza para mover el aire y aumentar la presión gracias a un impulsor rotativo situado dentro de un canal toroidal, que genera un aumento progresivo de la energía.

El término "**canal lateral**" deriva de la posición periférica del canal toroidal respecto al eje del impulsor.

## Design

A Side Channel Blower consists of an impeller with blades and a housing with a peripheral toroidal channel.

When used, the impeller rotates without touching the surrounding parts, and so wear-and-tear is avoided and lubrication is no longer needed.

The flow is channelled inward and outward by means of suitable silencers specially designed to reduce blower noise. All Side Channel Blowers manufactured by FPZ are covered by a **36-month warranty**.

## Design

La struttura della Soffiante a Canale Laterale è composta da una girante dalla quale si irradiano delle palette e da un alloggiamento nel quale viene ospitato un canale toroidale periferico.

Durante l'uso, la girante opera senza contatto con le parti circostanti, eliminando usura e necessità di lubrificazione. Il flusso è canalizzato, sia in entrata che in uscita, tramite opportuni silenziatori studiati appositamente per diminuire le emissioni acustiche della soffiante. Tutte le Soffianti a Canale Laterale prodotte da FPZ godono di una **garanzia di 36 mesi**.

## Diseño

La estructura de un Soplante de Canal Lateral se compone de un impulsor del cual irradian paletas y una carcasa en la que está alojado un canal toroidal periférico.

Durante su funcionamiento, el impulsor rota sin hacer contacto con las partes circundantes, eliminando desgastes y la necesidad de lubricación. El flujo, tanto entrante como saliente, se canaliza a través de silenciadores diseñados específicamente para reducir el ruido del soplante.

Todos los Soplantes de Canal Lateral producidos por FPZ están cubiertos por una **garantía de 36 meses**.

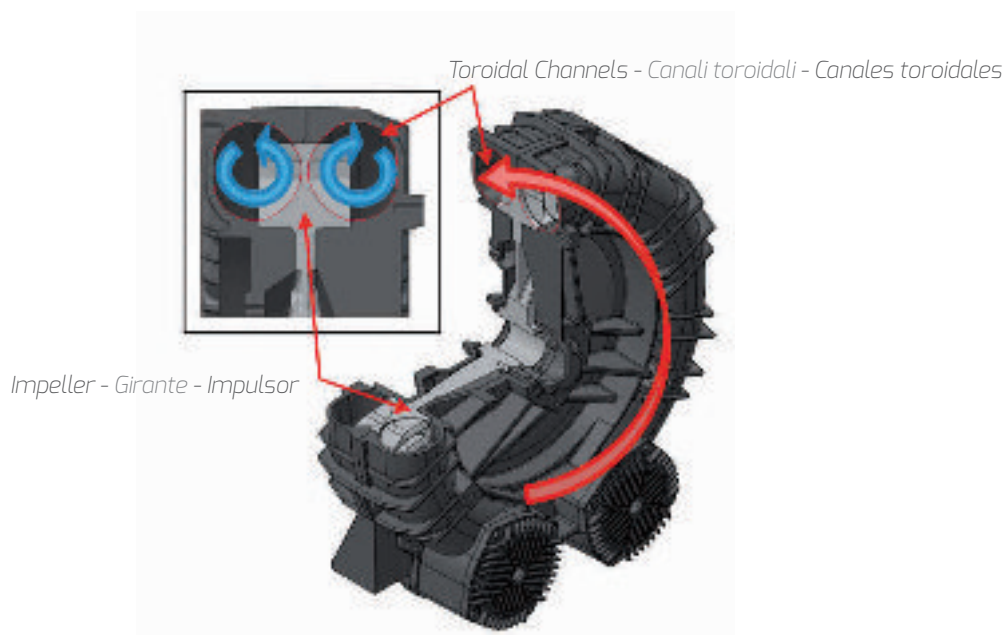

### Manufacture

Depending on the type of motor-blower connection, FPZ distinguishes the following types:

- **MOR**: the electric motor is directly connected to the impeller
- **GOR**: the electric motor is connected via a flexible coupling, horizontal installation
- **GVR**: the electric motor is connected via a flexible coupling, vertical installation

**Versatility and flexibility:** two concepts that are reflected in our special versions:

- Motors in different versions:
  - Eex(d)
  - IE2
  - NEMA PREMIUM
  - IE3
  - cURus
  - NEMA
  - ATEX
- TMS: decreases loss due to metal porosity
- TMD: for conveying hazardous fluids such as methane, biogas and technical gases
- ST-S with bare shaft

Also available:

- Impregnations
- Sealing, anodising with stainless steel bolts and screws and special protections for aggressive gases.

### Esecuzioni

In base al tipo di collegamento tra motore e soffiante, FPZ distingue i seguenti tipi di "esecuzione":

- **MOR**: il motore elettrico è direttamente collegato alla girante
- **GOR**: il motore elettrico è collegato tramite giunto elastico, assetto orizzontale
- **GVR**: il motore elettrico è collegato tramite giunto elastico, assetto verticale

**Versatilità e flessibilità:** due concetti che si rispecchiano nelle nostre versioni speciali.

- Motori in versione:
  - Eex(d)
  - IE2
  - NEMA PREMIUM
  - IE3
  - cURus
  - NEMA
  - ATEX
- TMS: permette un minor livello di perdita del fluido convogliato
- TMD: per il convogliamento di fluidi pericolosi tipo metano, biogas e gas tecnici
- ST-S: Ad albero nudo

Sono altresì disponibili:

- Impregnazioni
- Sigillature, anodizzazioni con viteria inox e protezioni speciali per gas aggressivi.

MOR

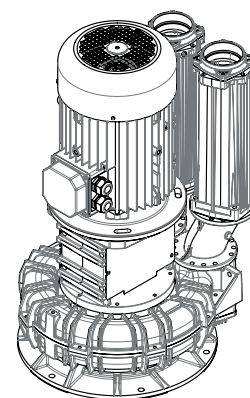
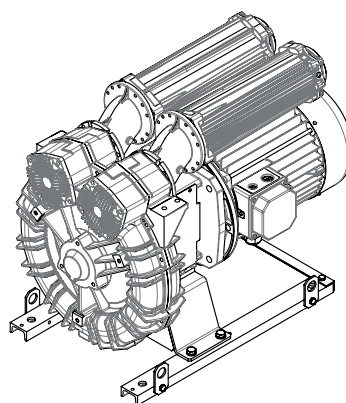
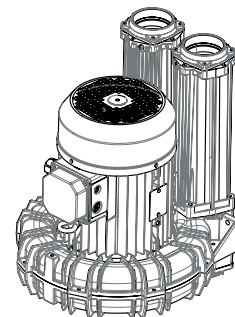
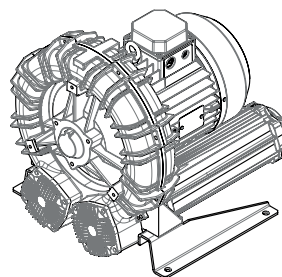

GOR

GVR

### Modelos

Dependiendo del tipo de conexión entre el motor y el soplante, FPZ produce con tres configuraciones:

- **MOR**: el motor eléctrico está conectado directamente al impulsor
- **GOR**: el motor eléctrico está conectado a través de un acoplamiento elástico, alineación horizontal
- **GVR**: el motor eléctrico está conectado a través de un acoplamiento elástico, alineación vertical

**Versatibilidad y flexibilidad:** dos conceptos que se reflejan en nuestras versiones especiales.

- Motores:
  - Eex(d)
  - IE2
  - NEMA PREMIUM
  - IE3
  - cURus
  - NEMA
  - ATEX

- TMS: permite un menor nivel de pérdida del fluido transportado
- TMD: para transportar fluidos peligrosos como metano, biogás o gases técnicos
- ST-S: con eje libre

También están disponibles:

- Tratamientos superficiales
- Sellado, anodizado, con tornillos de acero inoxidable y protecciones especiales para gases agresivos.

# SIDE CHANNEL BLOWERS

## Model arrangements

A Side Channel Blower can cover a wide range of flow/pressure combinations. The maximum flow rate that can be treated is 2400 m<sup>3</sup>/h while the relative pressure range goes from -450 mbar (vacuum) to +650 mbar (pressure). Thanks to the blower's modular features, this performance is achieved by combining the blower in different settings.

- MS: two channels arranged parallel to each other
  - MD: two channels arranged sequentially
- The acronyms MS and MD mean that the blower has one impeller (**M - mono**) and the compression is obtained through one (**S - single**) or two (**D - double**) transitions via the base module (single channel).

There are two double-impeller models available:

- TS: two MS blowers arranged parallel to each other
  - TD: two MS blowers arranged sequentially
- The acronyms TS and TD mean that the blower has two impellers (**T - twin**) and the compression is obtained through a (**S - single**) or two (**D - double**) transitions via the base module (MS). The diagram below summarises the configurations available.

## Installation

- For the machine to operate properly, it must have an intake filter and a vacuum/pressure relief valve
- Other accessories are available upon request (see page 34)
- Room and suction fluid temperature from -15°C to + 40°C

## Configurazioni

La Soffiante a Canale Laterale è in grado di coprire una vasta gamma di combinazioni di portata di flusso/pressione. La portata massima trattabile di flusso è 2400 m<sup>3</sup>/h mentre la gamma di pressione relativa va da -450 mbar (vuoto) a +650 mbar (pressione). Grazie alle sue caratteristiche modulari, queste prestazioni si ottengono combinando la soffiante in diversi assetti.

Su una singola girante sono disponibili due varianti:

- MS: due canali disposti in parallelo
- MD: due canali disposti in serie

Gli acronimi MS e MD significano che la soffiante è dotata di una girante (**M - mono**) e che la compressione è ottenuta attraverso una (**S - singola**) o due (**D - doppia**) transizioni tramite il modulo di base (canale singolo).

Su una doppia girante sono disponibili altre due varianti:

- TS: due soffianti MS disposte in parallelo
- TD: due soffianti MS disposte in serie

Gli acronimi TS e TD significano che la soffiante è dotata di due giranti (**T - coppia**) e che la compressione è ottenuta attraverso una (**S - singola**) o due (**D - doppia**) transizioni tramite il modulo di base (MS). Lo schema seguente riassume le configurazioni disponibili.

## Installazione

- Per un corretto funzionamento della macchina la stessa deve essere corredata di un filtro in aspirazione e di una valvola di limitazione del vuoto/pressione
- Altri accessori sono disponibili su richiesta (vedi da pag 34)
- Temperatura ambiente e del fluido in aspirazione da -15°C to +40°C

## MS

Single impeller single stage  
Mono girante singolo stadio  
Impulsor mono etapa

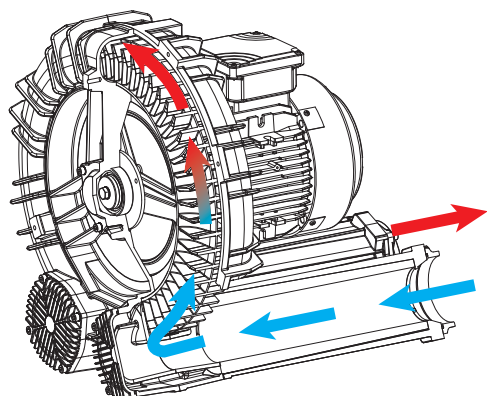

## TS

Twin impeller single stage  
Doppia girante singolo stadio  
Doble impulsor mono etapa

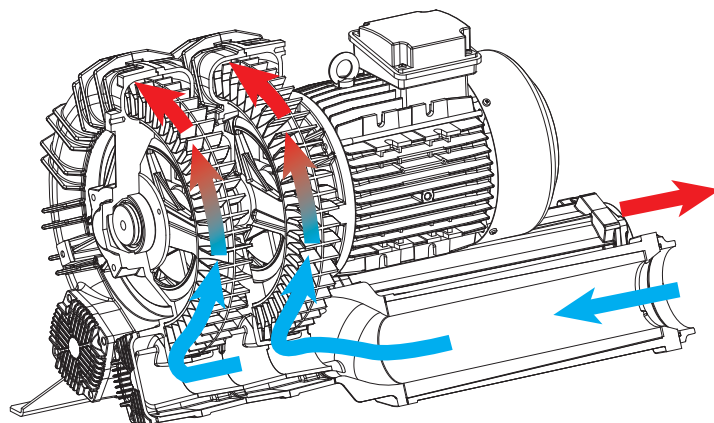



### Configuraciones

Los Soplantes de Canal Lateral cubren una amplia gama de combinaciones según el caudal de flujo y presión. El caudal de flujo máximo es de 2.400 m<sup>3</sup>/h, mientras que el intervalo de presión relativa es de -450 mbar (vacío) a +650 mbar (presión). Gracias a sus características modulares, el rendimiento requerido se consigue combinando el soplante en sus diferentes configuraciones.

Cada impulsor puede operar en dos variantes:

- MS: dos canales paralelos
- MD: dos canales en serie

Las siglas MS y MD se refieren a que el soplante posee un solo impulsor (**M - mono**) y que la compresión se obtiene a través de una (**S - única**) o dos (**D - doble**) etapas a través del módulo de base (un solo canal).

Los soplantes de dos impulsores poseen dos variantes:

- TS: Dos impulsores MS paralelos
- TD: Dos impulsores MS en serie

Las siglas TS y TD se refieren a que el soplante está equipado con dos impulsores (**T - pareja**) y que la compresión se obtiene a través de una (**S - única**) o dos (**D - doble**) etapas a través del módulo de base (MS). El siguiente diagrama resume las configuraciones disponibles.

### Instalación

- Para un correcto funcionamiento de la máquina la misma debe estar equipada con un filtro en la aspiración y una válvula de alivio vacío/presión.
- Otros accesorios están disponibles por pedido (véase página 34)
- El intervalo de temperatura de funcionamiento para el flujo en entrada es de -15 °C a +40 °C

## MD

Single impeller double stage  
 Mono girante doppio stadio  
 Impulsor doble etapa

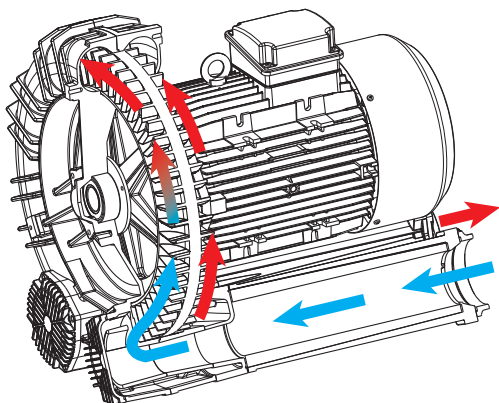

## TD

Twin impeller double stage  
 Doppia girante doppio stadio  
 Doble impulsor doble etapa

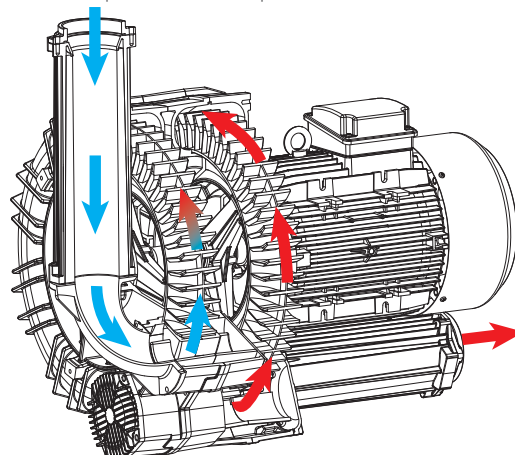



## FPZ Green

La gamma di prodotti FPZ è ora completa di soluzioni per garantire un miglior rendimento, efficienza ed affidabilità; questo è quanto di meglio si possa avere per conseguire un notevole risparmio energetico.

### **Efficienza Energetica dei Motori Elettrici**

Il consumo di energia elettrica negli ultimi anni nei paesi industrializzati è aumentato notevolmente. FPZ è da sempre attenta all'evoluzione tecnologica ed al rispetto dell'ambiente e per queste motivazioni risponde come standard con il suo prodotto Monoblocco dai requisiti di alta efficienza quali:

- IE 2 / IE 3: Alta Efficienza per potenze maggiori di 0,37 kW
- IE 3 Nema Premium: per motori elettrici destinati al mercato Canadese ed USA

## FPZ Green

FPZ's product range now offers solutions that ensure better performance, efficiency and reliability. This is the best you can have in order to achieve significant energy saving.

### **Energy Efficiency of Electric Motors**

In recent years the consumption of electricity in developed countries has increased significantly. FPZ is always on the cutting edge of technological innovation and environmental protection, and for these reasons, its Monobloc product features, as standard, high efficiency requirements such as:

- IE 2 / IE 3: High efficiency for power above 0.37 kW
- IE 3 Nema Premium: for electric motors intended for the Canadian and US markets

## FPZ Green

Los productos de FPZ forman una gama completa de soluciones que garantizan el mejor rendimiento, eficiencia y fiabilidad con gran atención al ahorro energético.

### **Eficiencia Energética de los Motores Eléctricos**

El consumo de electricidad en los últimos años en los países industrializados ha aumentado significativamente. FPZ siempre ha estado atento a la evolución tecnológica y al respeto del medio ambiente y por estas razones ha desarrollado soluciones como el Monobloque que obedece a los más rigurosos requisitos de eficiencia:

- IE 2 / IE 3: Alta eficiencia para potencias > 0,37 Kw
- IE 3 Nema Premium: para motores eléctricos destinados a los mercados de Canadá y EE.UU.

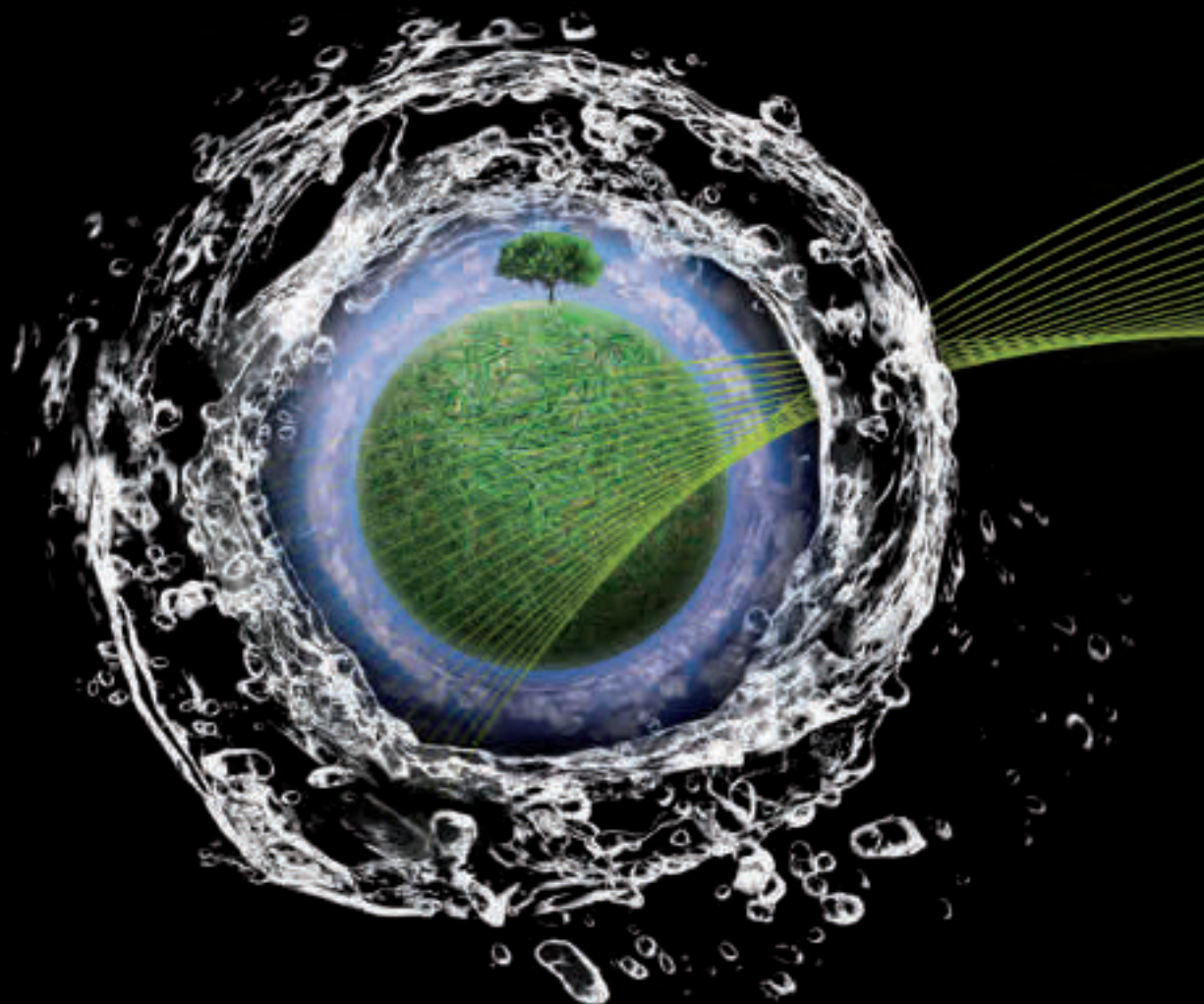

## IE3 Wide Range

### IE3 Wide Range - cURus

All FPZ blowers come equipped with IE2 or IE3 motors, designed and manufactured according to the directive Ecodesign 2009/125/CE (CE n.640/2009 and UE n.4/2014) and according to (including future variants) EN 60034-30-1, EN 60034-2-1. These motors are also designed to perform safely under a wide range of voltages (**Wide Range**). The IE3 motors also comply to the cURus standard of certification for the Canadian and USA market, according to the electric rotating machinery safety norms. UL 1004-1 & C22.2 N.100-04



### IE3 Wide Range - cURus

Tutte le soffianti FPZ sono equipaggiate con motori elettrici marcati IE2 o IE3, progettati e costruiti in conformità alla Direttiva Ecodesign 2009/125/CE (Regolamento CE n.640/2009 e Regolamento UE n.4/2014) e alle norme (e successive varianti) EN 60034-30-1, EN 60034-2-1. Tali motori sono adeguatamente dimensionati per poter funzionare in sicurezza all'interno di un range allargato di tensioni (**Wide Range**). I motori sono inoltre marcati cURus, certificati per il mercato USA e Canada in conformità alle norme generali di sicurezza per macchine elettriche rotanti. UL 1004-1 e C22.2 N.100-04

### IE3 Wide Range - cURus

Todas las soplantes FPZ están equipadas con motores eléctricos marcados IE2 o IE3 diseñados y construidos conforme a la directiva Ecodesign 2009/125/CE (Reglamento CE N640/2009 y reglamento UE n.4/2014) y a las normas (y sucesivas variantes) EN 60034-30-1, EN 60034-2-1. Tales motores están adecuadamente dimensionados para poder trabajar con seguridad al interior de un amplio rango de voltajes (**Wide Range**). Los motores, además, están marcados con la enseña cURus certificados para el mercado USA y Canadá y conformes a las normas generales de seguridad para máquinas eléctricas rotantes. UL 1004-1 & C22.2 N.100-04.



## IE3 NEMA Premium

Electric motors (both closed or open to be used on machinery) for sale on the Canadian or USA market, produced after 1 June 2016, are required to be certified for energy efficiency IE3 Nema Premium (**Rated power between 1 HP and 500 HP**). (Federal Register/Vol. 79, No.103 / Thursday, May 29, 2014/Rules and Regulations (page 31010 et seq) © U.S. Government publishing office)



I motori elettrici (sia chiusi che aperti ed utilizzati in macchine) destinati al mercato Canadese ed USA prodotti dopo il 1 Giugno 2016 devono essere certificati NEMA Premium (**Potenza nominale compresa tra 1HP e 500HP**).

(Federal Register / Vol. 79, No. 103 / Thursday, May 29, 2014 / Rules and Regulations (pag 31010 e seguenti) © U.S. Government publishing office1

Los motores eléctricos (ambos cerrados y abiertos y aquellos utilizados en las máquinas) destinados al mercado canadiense y estadounidense deben estar certificados NEMA Premium (**potencial nominal entre 1 HP y 500 HP**) a partir del 1 de Junio 2016. (Federal Register / Vol. 79, No. 103 / Thursday, May 29, 2014 / Rules and Regulations (pág. 31010 y siguientes) © U.S. Government publishing office1



Single impeller - Single stage  
Mono girante - Singolo stadio  
Mono impulsor - Mono etapa

# SIDE CHANNEL BLOWERS

# MS

*Intake compression features*

*Caratteristiche in compressione ed aspirazione*

*Características en compresión y aspiración*

fpz.com



TS

*Twin impeller - Single stage  
Doppia girante - Singolo stadio  
Doble impulsor - Mono etapa*

MD

*Single impeller - Double stage  
Mono girante - Doppio stadio  
Mono impulsor - Doble etapa*

TD

*Twin impeller - Double stage  
Doppia girante - Doppio stadio  
Doble impulsor - Doble etapa*

# SIDE CHANNEL BLOWERS

## Technical specifications

- Aluminium alloy construction
- Low noise level
- Maintenance-free
- Maximum flow: 2400 m<sup>3</sup>/h @ 60 Hz
- Maximum pressure: 650 mbar
- Maximum Vacuum: -450 mbar (rel)

## Electric Motor

- High efficiency: IE3
- Power: 0.2 - 37.0 kW
- IP 55 Motors
- Insulation class F, suitable for inverters
- PTO thermal protector as standard
- Extended range of supply voltages

## Options

- Single phase motors (up to 2.2 kW)
- Special voltages (IEC 60038)
- Surface protection treatments
- Enhanced sealing version

## Caratteristiche tecniche

- Costruzione in lega d'alluminio
- Funzionamento silenzioso
- Nessuna necessità di manutenzione
- Portata massima: 2400 m<sup>3</sup>/h @ 60 Hz
- Pressione massima: 650 mbar
- Vuoto massimo: -450 mbar (rel)

## Motore Elettrico

- Alta efficienza: IE3
- Potenza: 0.2 - 37.0 kW
- Motori con grado IP 55
- Classe di isolamento F, idoneo per inverter
- Protettore termico PTO di serie
- Range esteso di Tensioni di alimentazione

## Opzioni

- Motori Monofase (sino a 2.2 kW)
- Tensioni speciali (IEC 60038)
- Trattamenti protettivi delle superfici
- Versione a tenuta aumentata

## Especificaciones técnicas

- Cuerpo de aleación de aluminio
- Funcionamiento silencioso
- Libre de mantenimiento
- Caudal de flujo máximo: 2.400 m<sup>3</sup>/h @ 60 Hz
- Presión máxima: 650 mbar
- Vacío máximo: -450 mbar (REL)

## Motor Eléctrico

- Alto rendimiento: IE3
- Potencias: 0.2 - 37,0 kW
- Motores con protección IP 55
- Clase de aislamiento F, idóneo para inverter
- Protector térmico PTO en todos los modelos
- Amplia gama de voltajes de alimentación

## Opcional

- Motores monofásicos (hasta 2,2 Kw)
- Voltajes especiales (IEC 60038)
- Tratamientos superficiales específicos
- Versiones con mayor nivel de sellado

Tolerance for the fixed voltage value  $\pm 10\%$ , for the range  $\pm 5\%$ .

Tolleranza sul valore fisso di tensione  $\pm 10\%$ , sul range  $\pm 5\%$ .

Tolerancia respecto al voltaje  $\pm 10\%$ , al intervalo  $\pm 5\%$ .

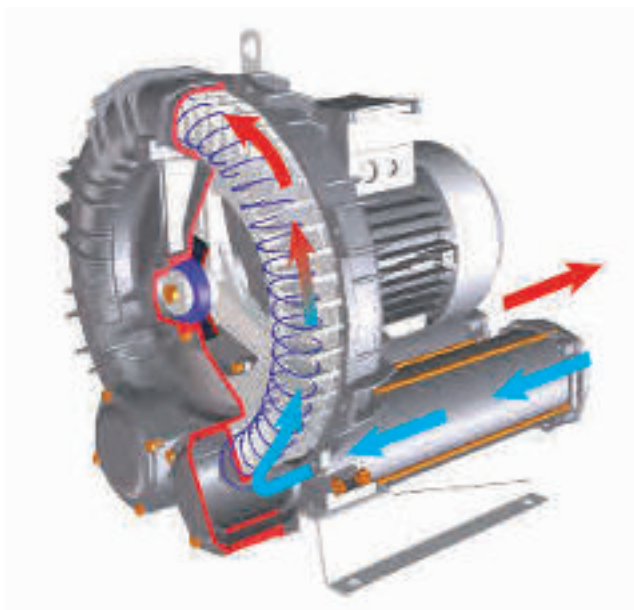

Table nr. 1 – Wide Range

Tabella nr. 1 – Wide Range

Tabla n.ro 1 - Amplio Rango

Voltage range Range di Tensione Rango de voltaje	Tolerance Tolleranza Tolerancia	Frequency Frequenza Frecuencia
200 / 240 – 345 – 415	± 5 %	50 Hz
345 – 415 / 600 – 720		
220 – 280 / 380 – 480	± 5 %	60 Hz
380 – 480 / 660 – 830		

#### IE3 Wide Range - cURus

All FPZ blowers come equipped with IE2 or IE3 motors, designed and manufactured according to the directive Ecodesign 2009/125/CE (CE n.640/2009 and UE n.4/2014) and according to (including future variants) EN 60034-30-1, EN 60034-2-1. These motors are also designed to perform safely under a wide range of voltages (**Wide Range**). The IE3 motors also comply to the cURus standard of certification for the Canadian and USA market, according to the electric rotating machinery safety norms. UL 1004-1 & C22.2 N.100-04.

#### IE3 Wide Range - cURus

Tutte le soffianti FPZ sono equipaggiate con motori elettrici marcati IE2 o IE3, progettati e costruiti in conformità alla Direttiva Ecodesign 2009/125/CE (Regolamento CE n.640/2009 e Regolamento UE n.4/2014) e alle norme (e successive varianti) EN 60034-30-1, EN 60034-2-1. Tali motori sono adeguatamente dimensionati per poter funzionare in sicurezza all'interno di un range allargato di tensioni (**Wide Range**). I motori sono inoltre marcati cURus, certificati per il mercato USA e Canada in conformità alle norme generali di sicurezza per macchine elettriche rotanti. UL 1004-1 e C22.2 N.100-04.

#### IE3 Wide Range - cURus

Todas las soplantes FPZ están equipadas con motores eléctricos marcados IE2 o IE3 diseñados y construidos conforme a la directiva Ecodesign 2009/125/CE (Reglamento CE N640/2009 y reglamento UE n.4/2014) y a las normas (y sucesivas variantes) EN 60034-30-1, EN 60034-2-1. Tales motores están adecuadamente dimensionados para poder trabajar con seguridad al interior de un amplio rango de voltajes (**Wide Range**). Los motores, además, están marcados con la enseña cURus certificados para el mercado USA y Canadá y conformes a las normas generales de seguridad para máquinas eléctricas rotantes. UL 1004-1 & C22.2 N.100-04.

Table nr. 2 – cURus

Tabella nr. 2- cURus

Tabla n.ro 2 – cURus

Voltage range Range di Tensione Rango de voltaje	Frequency Frequenza Frecuencia	Power Potenza Potencia	S.F. S.F. S.F.
(~1) 115/230	60 Hz	<= 4 HP	
(~3) 208 - 230/460	60 Hz	1/3HP – 30HP	1.15
230/400	50 Hz		

#### IE3 Nema Premium

Electric motors (both closed or open to be used on machinery) for sale on the **Canadian or USA market**, produced after 1 June 2016, are required to be certified for energy efficiency IE3 Nema Premium (Rated power between 1 HP and 500 HP) (Federal Register / Vol. 79, No.103 / Thursday, May 29, 2014 / Rules and Regulations (page 31010 et seq) © U.S. Government publishing office)

#### IE3 Nema Premium

I motori elettrici destinati al mercato Canadese ed USA prodotti dopo il 1 Giugno 2016 devono essere certificati NEMA Premium (Potenza nominale compresa tra 1HP e 500HP) (Federal Register / Vol. 79, No. 103 / Thursday, May 29, 2014 / Rules and Regulations (pag 31010 e seguenti) © U.S. Government publishing office1, indicato in tabella 2. (per ulteriori informazioni contattateci su [www.fpz.com](http://www.fpz.com))

#### IE3 Nema Premium

Los motores eléctricos destinados al mercado canadiense y estadounidenses deben poseer certificación NEMA Premium (potencia nominal entre 1 HP y 500 HP) desde el 1 de junio, el año 2016 (Federal Register / Vol. 79, No. 103 / Thursday, May 29, 2014 / Rules and Regulations (pág. 31010 y siguientes) © U.S. Government publishing office1, indicado en la tabla 2. (para más información póngase en contacto a través de [www.fpz.com](http://www.fpz.com))

# SIDE CHANNEL BLOWERS

## MS TS

Compression - Compressione - Compresión **50Hz**

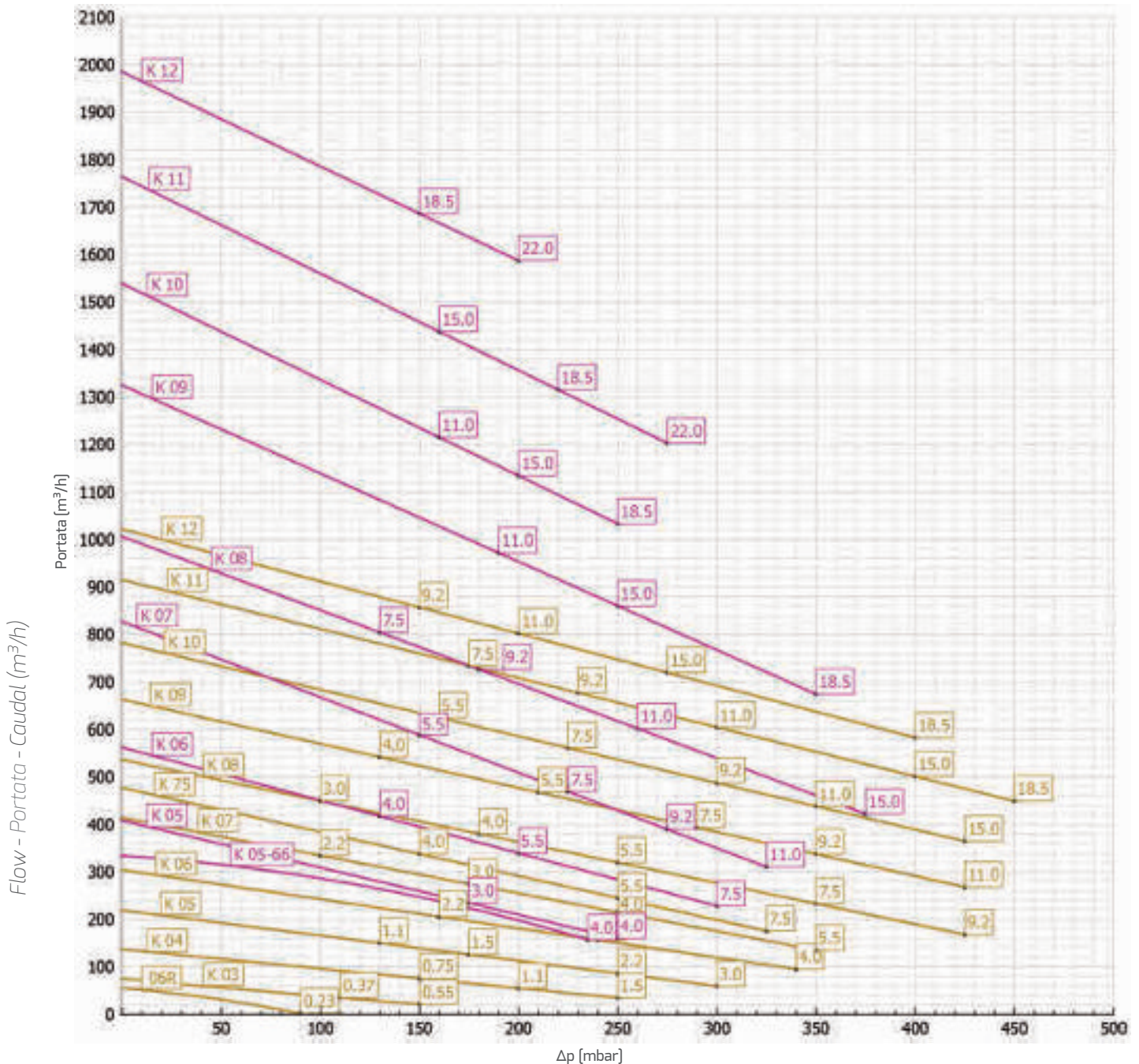

Static differential pressure - *Pressione differenziale statica*  
 Presión diferencial estática hPa (mbar)

Tolerance on indicated values +/- 10%. Specifications subject to change without notice.

Curves refer to air at 20°C and 1013 mbar (abs) atmospheric pressure.

*Tolleranza sui valori indicati +/- 10%. Dati soggetti a variazione senza obbligo di preavviso.*

*Curve riferite ad aria ad una temperatura di 20°C e a pressione atmosferica di 1013 mbar (abs)*

La tolerancia en los valores indicados es de +/-10%. Información está sujeta a cambios sin previo aviso.

Las curvas se refieren a aire a una temperatura de 20 °C y presión atmosférica de 1013 mbar (abs).



# MD TD

Compression - Compressione - Compresión **50Hz**

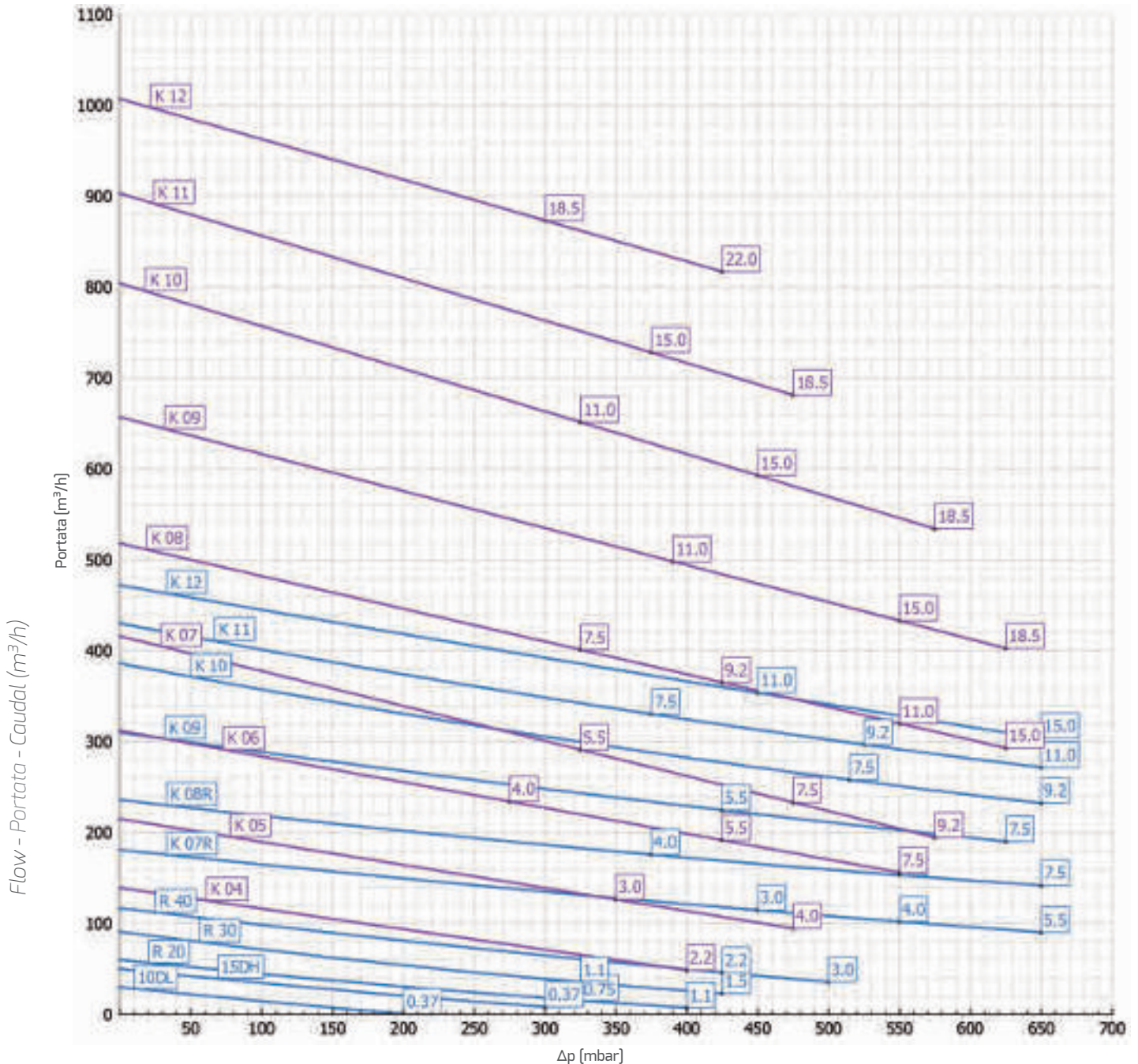

Static differential pressure - Pressione differenziale statica  
Presión diferencial estática hPa (mbar)

Tolerance on indicated values +/- 10%. Specifications subject to change without notice.

Curves refer to air at 20°C and 1013 mbar (abs) atmospheric pressure.

Tolleranza sui valori indicati +/- 10%. Dati soggetti a variazione senza obbligo di preavviso.

Curve riferite ad aria ad una temperatura di 20°C e a pressione atmosferica di 1013 mbar (abs)

La tolerancia en los valores indicados es de +/-10%. Información está sujeta a cambios sin previo aviso.

Las curvas se refieren a aire a una temperatura de 20 °C y presión atmosférica de 1013 mbar (abs).

# SIDE CHANNEL BLOWERS

## MS TS

Suction - Aspirazione - Aspiración **50Hz**

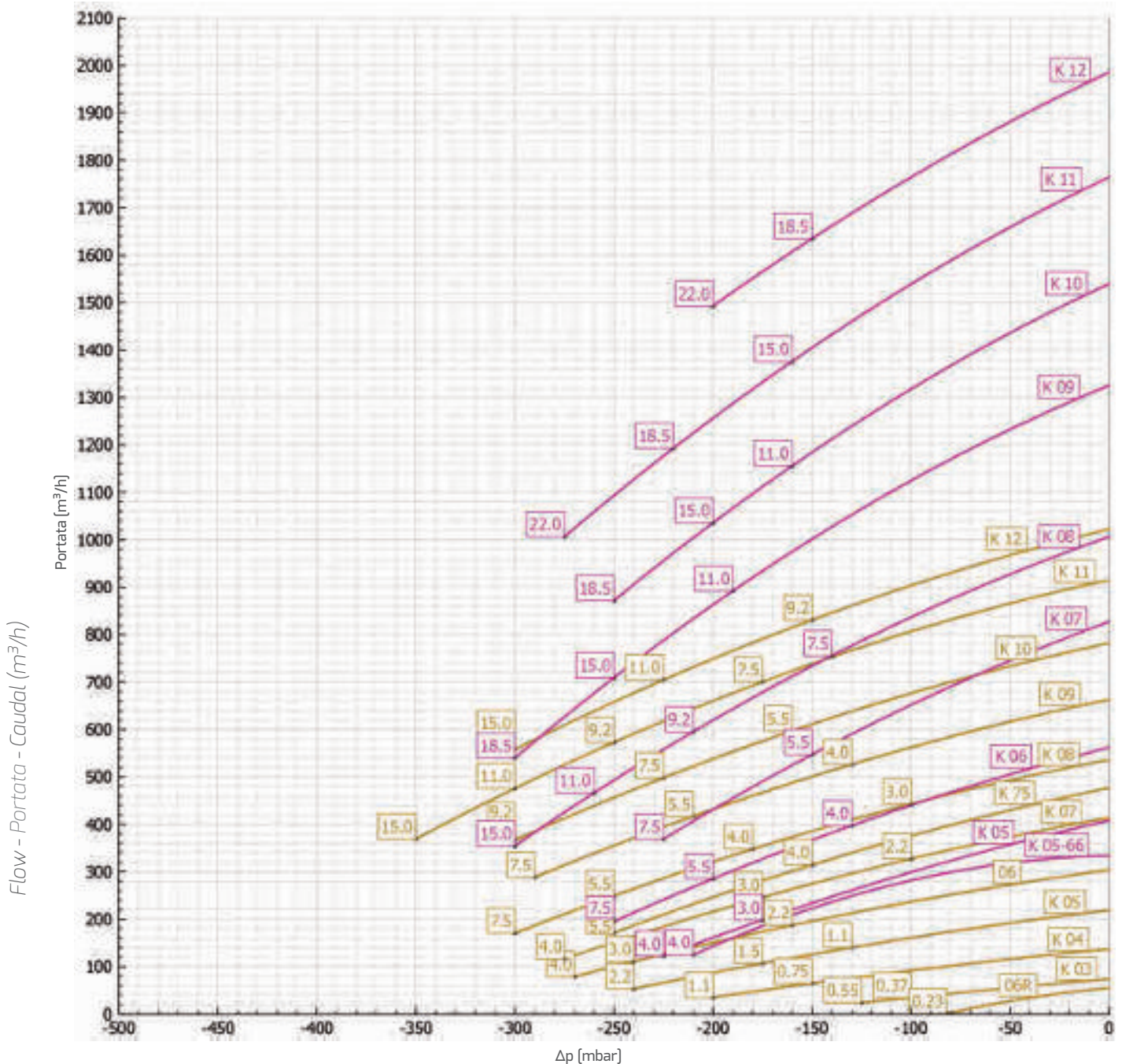

Flow - Portata - Caudal ( $m^3/h$ )

Static differential pressure - Pressione differenziale statica  
Presión diferencial estática hPa (mbar)

Tolerance on indicated values +/- 10%. Specifications subject to change without notice.

Curves refer to air at 20°C and 1013 mbar (abs) atmospheric pressure.

Tolleranza sui valori indicati +/- 10%. Dati soggetti a variazione senza obbligo di preavviso.

Curve riferite ad aria ad una temperatura di 20°C e a pressione atmosferica di 1013 mbar (abs)

La tolerancia en los valores indicados es de +/-10%. Información está sujeta a cambios sin previo aviso.

Las curvas se refieren a aire a una temperatura de 20 °C y presión atmosférica de 1013 mbar (abs).

# MD TD

Suction - Aspirazione - Aspiración **50Hz**

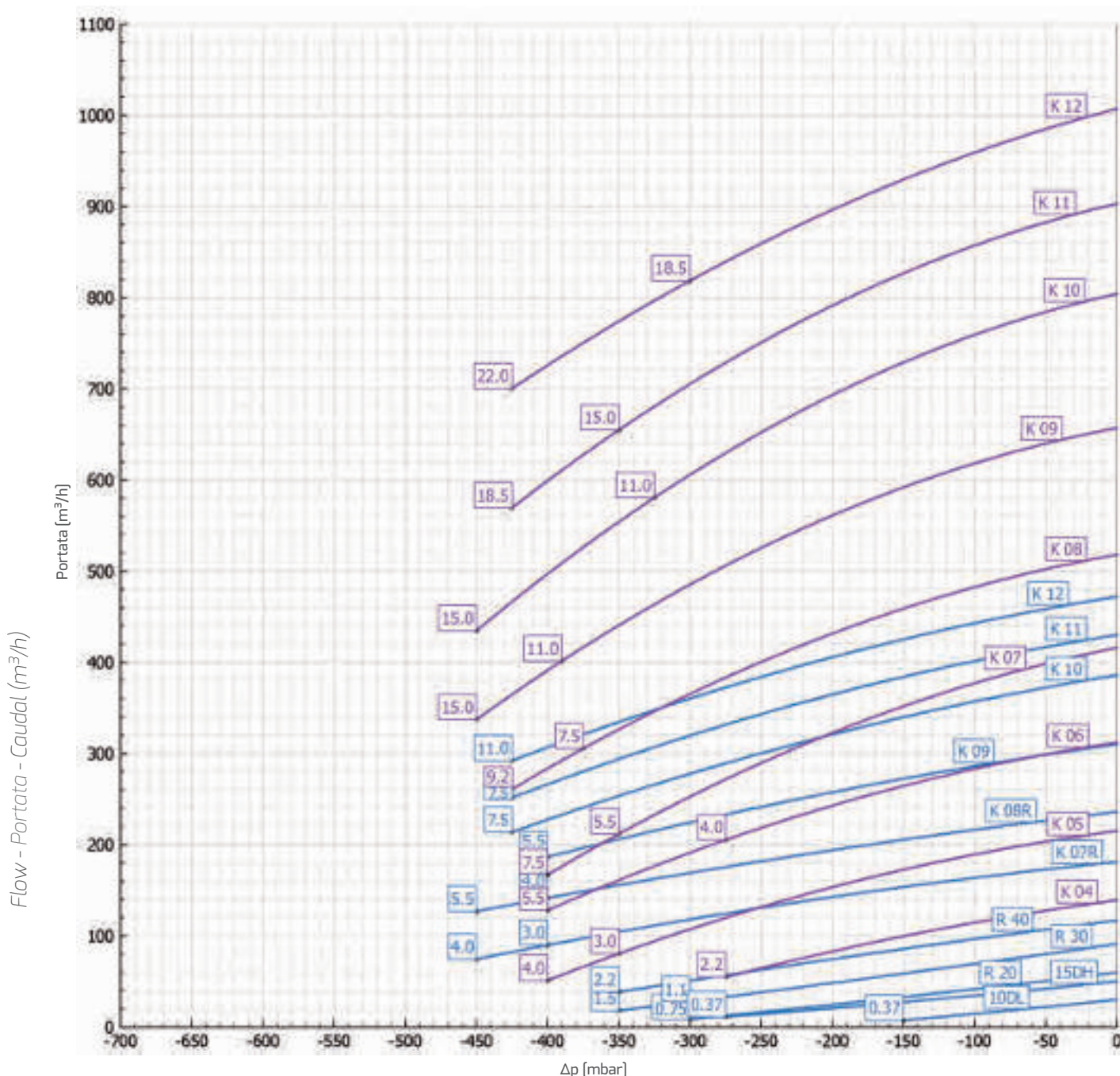

Static differential pressure - Pressione differenziale statica  
Presión diferencial estática hPa (mbar)

Tolerance on indicated values +/- 10%. Specifications subject to change without notice.

Curves refer to air at 20°C and 1013 mbar (abs) atmospheric pressure.

Tolleranza sui valori indicati +/- 10%. Dati soggetti a variazione senza obbligo di preavviso.

Curve riferite ad aria ad una temperatura di 20°C e a pressione atmosferica di 1013 mbar (abs)

La tolerancia en los valores indicados es de +/-10%. Información está sujeta a cambios sin previo aviso.

Las curvas se refieren a aire a una temperatura de 20 °C y presión atmosférica de 1013 mbar (abs).

# SIDE CHANNEL BLOWERS

## MS TS

Compression - Compressione - Compresión **60Hz**

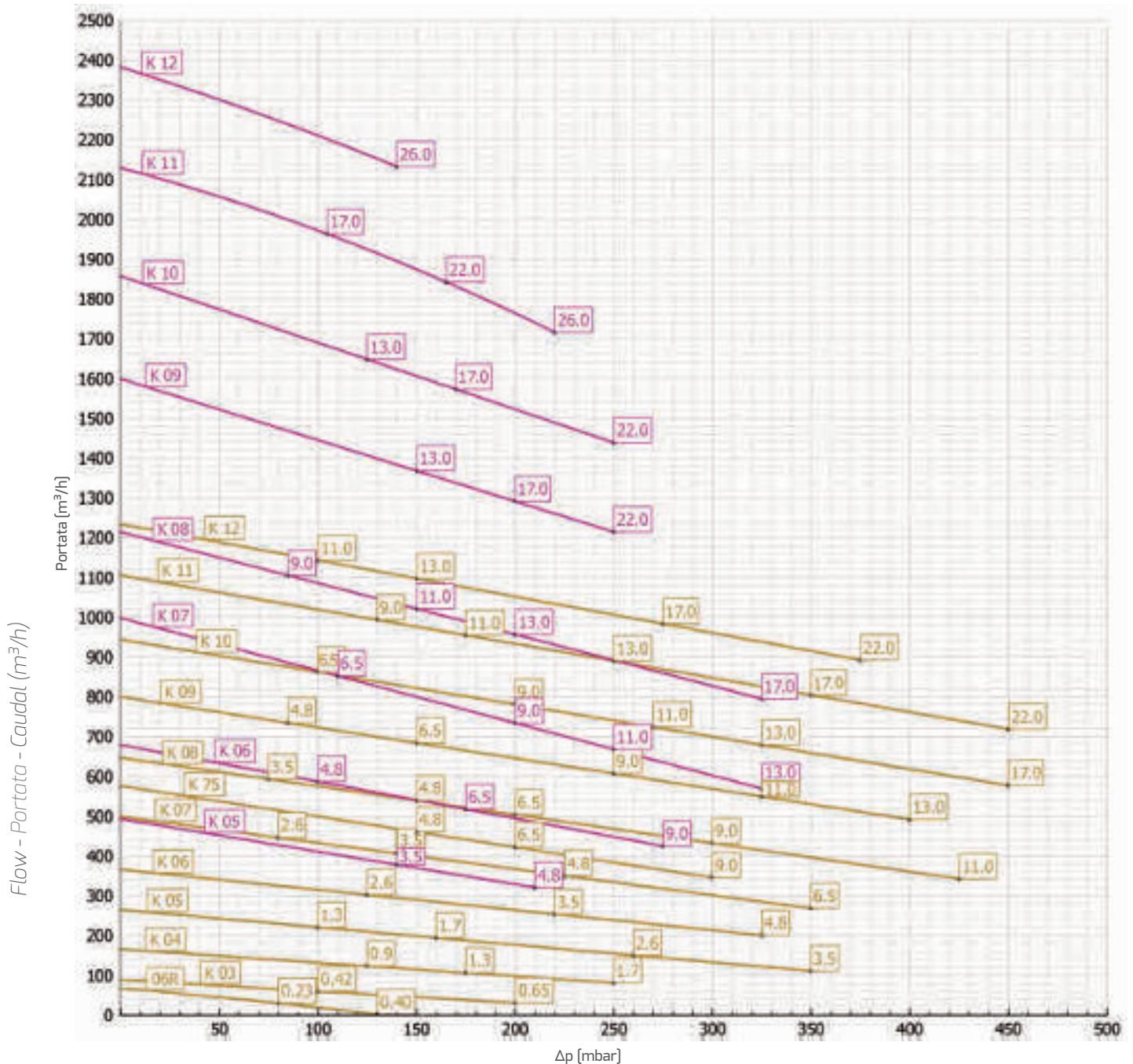

Static differential pressure - *Pressione differenziale statica*  
 Presión diferencial estática hPa (mbar)

Tolerance on indicated values +/- 10%. Specifications subject to change without notice.

Curves refer to air at 20°C and 1013 mbar (abs) atmospheric pressure.

*Tolleranza sui valori indicati +/- 10%. Dati soggetti a variazione senza obbligo di preavviso.*

*Curve riferite ad aria ad una temperatura di 20°C e a pressione atmosferica di 1013 mbar (abs)*

La tolerancia en los valores indicados es de +/-10%. Información está sujeta a cambios sin previo aviso.

Las curvas se refieren a aire a una temperatura de 20 °C y presión atmosférica de 1013 mbar (abs).

# MD TD

Compression - Compressione - Compresión **60Hz**

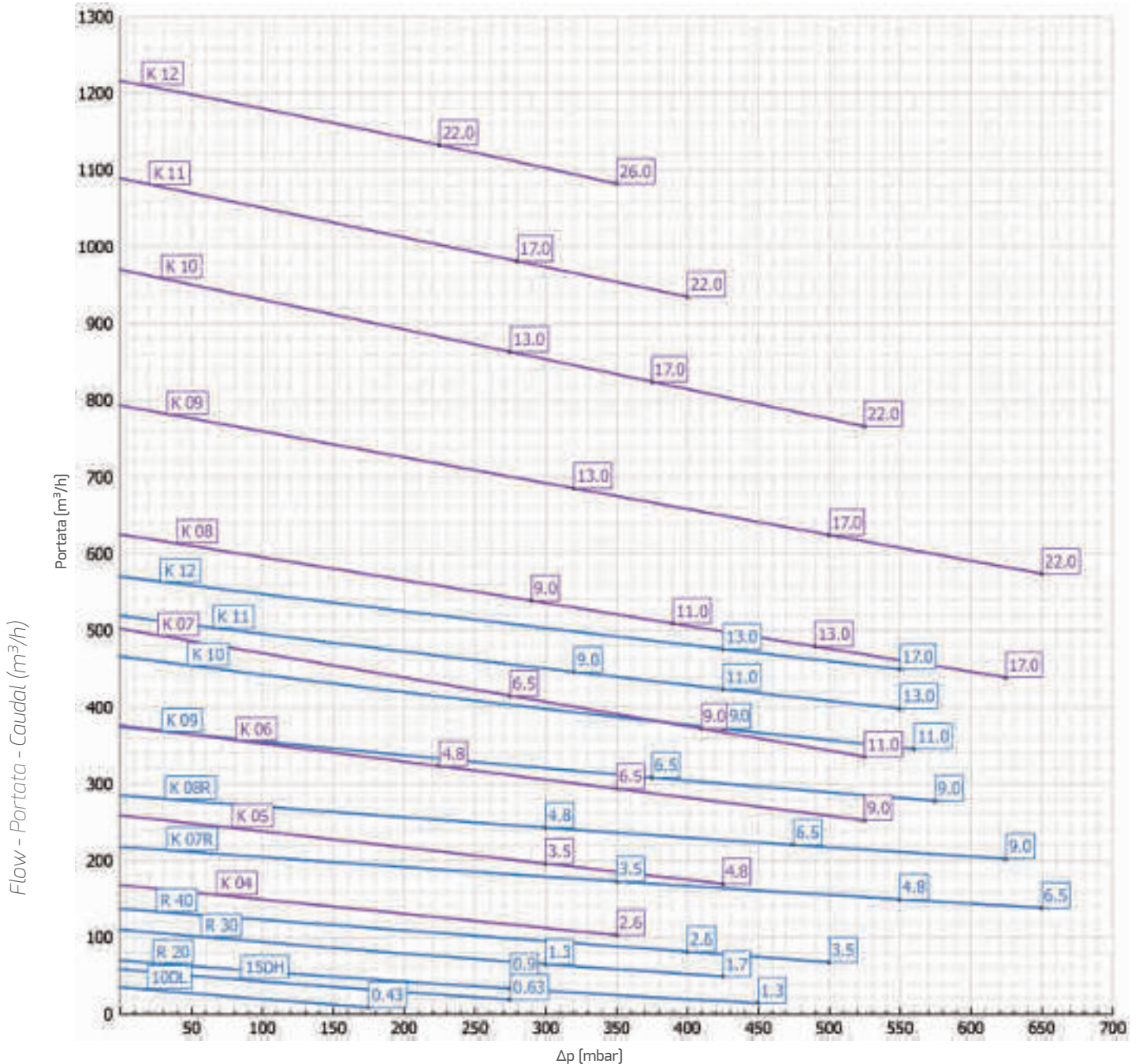

Static differential pressure - Pressione differenziale statica  
 Presión diferencial estática hPa (mbar)

Tolerance on indicated values +/- 10%. Specifications subject to change without notice.

Curves refer to air at 20°C and 1013 mbar (abs) atmospheric pressure.

Tolleranza sui valori indicati +/- 10%. Dati soggetti a variazione senza obbligo di preavviso.

Curve riferite ad aria ad una temperatura di 20°C e a pressione atmosferica di 1013 mbar (abs)

La tolerancia en los valores indicados es de +/-10%. Información está sujeta a cambios sin previo aviso.

Las curvas se refieren a aire a una temperatura de 20 °C y presión atmosférica de 1013 mbar (abs).

# SIDE CHANNEL BLOWERS

## MS TS

Suction - Aspirazione - Aspiración **60Hz**

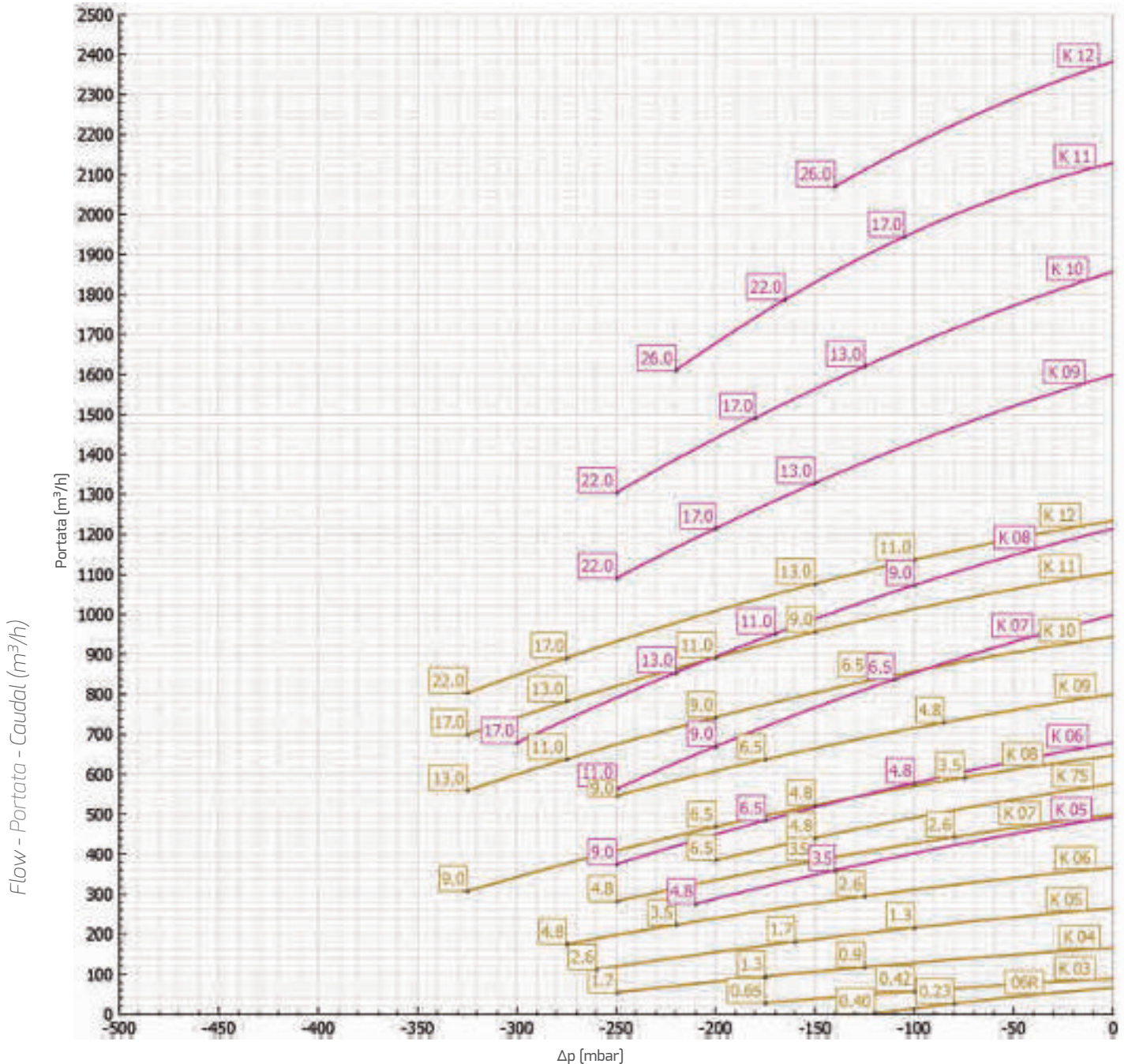

Static differential pressure - *Pressione differenziale statica*  
 Presión diferencial estática hPa (mbar)

Tolerance on indicated values +/- 10%. Specifications subject to change without notice.

Curves refer to air at 20°C and 1013 mbar (abs) atmospheric pressure.

*Tolleranza sui valori indicati +/- 10%. Dati soggetti a variazione senza obbligo di preavviso.*

*Curve riferite ad aria ad una temperatura di 20°C e a pressione atmosferica di 1013 mbar (abs)*

La tolerancia en los valores indicados es de +/-10%. Información está sujeta a cambios sin previo aviso.

Las curvas se refieren a aire a una temperatura de 20 °C y presión atmosférica de 1013 mbar (abs).

# MD TD

Suction - Aspirazione - Aspiración **60Hz**

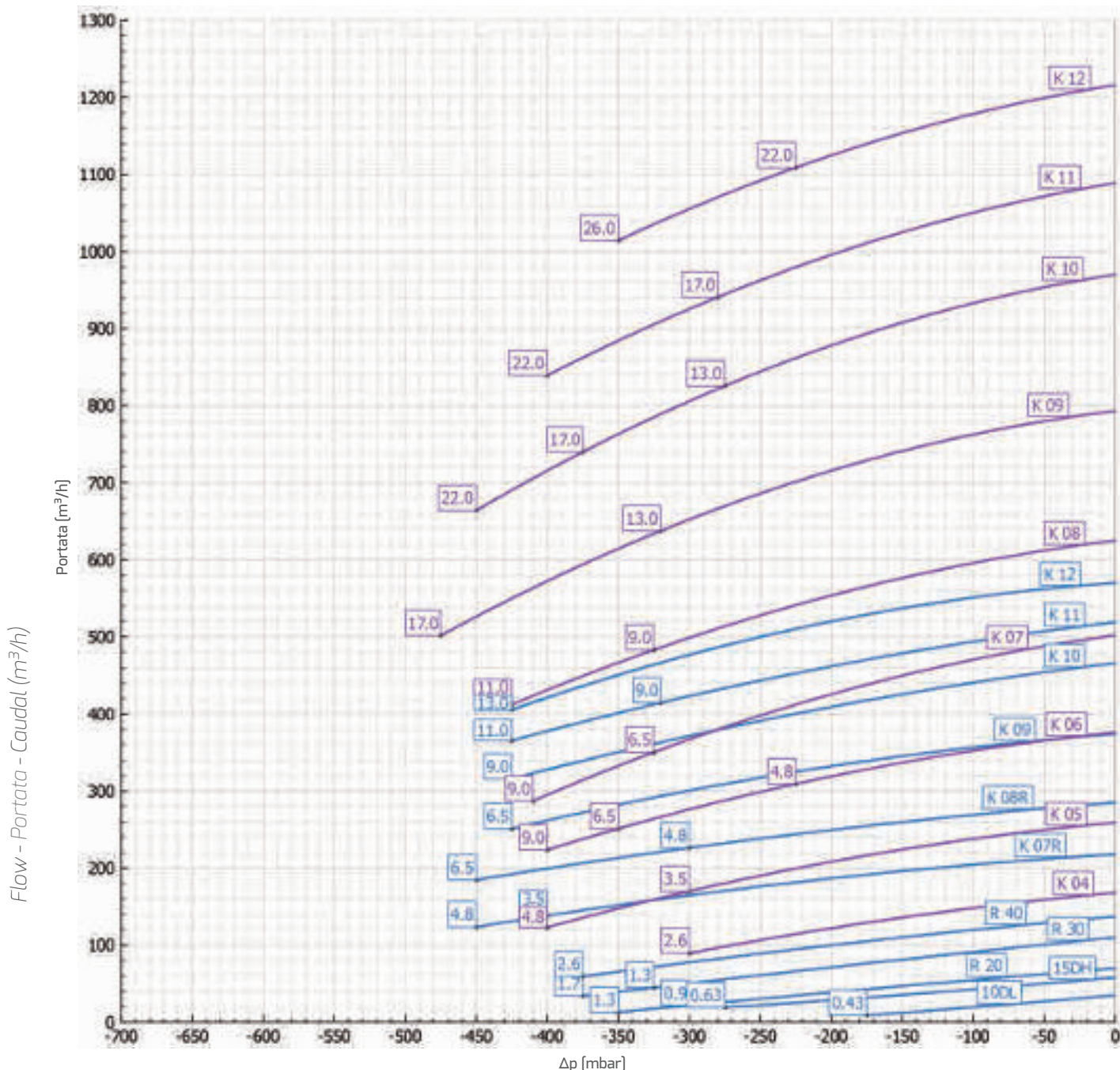

Static differential pressure - Pressione differenziale statica  
Presión diferencial estática hPa (mbar)

Tolerance on indicated values +/- 10%. Specifications subject to change without notice.

Curves refer to air at 20°C and 1013 mbar (abs) atmospheric pressure.

Tolleranza sui valori indicati +/- 10%. Dati soggetti a variazione senza obbligo di preavviso.

Curve riferite ad aria ad una temperatura di 20°C e a pressione atmosferica di 1013 mbar (abs)

La tolerancia en los valores indicados es de +/-10%. Información está sujeta a cambios sin previo aviso.

Las curvas se refieren a aire a una temperatura de 20 °C y presión atmosférica de 1013 mbar (abs).

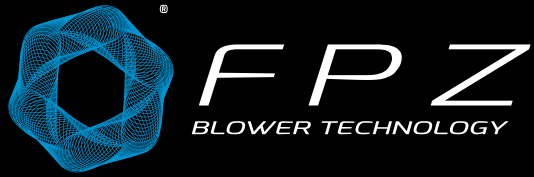

# *SIDE CHANNEL BLOWERS*

*Overall dimensions*

*Ingombri*

*Dimensiones*

[fpz.com](http://fpz.com)





# SIDE CHANNEL BLOWERS

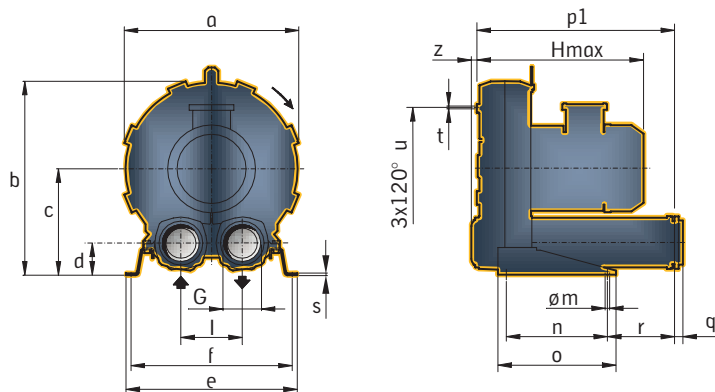

MS

K03 / K04 / K05 / K06 / K07 / K75  
K08 / K09 / K10 / K11 / K12

Mod	a	b	c	d	e	f	G	l	øm	n	o	p1	q	r	s	t	u	z	Hmax*
K03 MS	241	268	147	43	230	205	G 1" 1/4	86	10	83	142	205	18	75	4	M6	140	12	300
K04 MS	285	315	172	49	255	225	G 1" 1/2	102	12	95	171	222	18	70	4	M6	175	18	335
K05 MS	327	365	200	54	325	260	G 2"	120	15	115	265	320	18	98	4	M8	200	19	375
K06 MS	376	393	205	54	325	290	G 2"	125	15	140	265	334	18	85	4	M8	240	19	385
K07 MS	424	481	269	82	470	438	G 3"	155	13	300	350	512	25	137	5	M8	295	16	450
K75 MS	424	481	269	82	470	438	G 3"	155	13	300	350	512	25	137	5	M8	295	16	450
K08 MS	457	498	269	82	480	448	G 3"	155	13	300	350	512	25	137	5	M8	310	16	485
K09 MS	492	561	315	96	510	478	G 4"	182	13	300	350	586	25	199	5	M8	360	16	590
K10 MS	516	573	315	96	510	478	G 4"	182	13	300	350	586	25	199	5	M8	360	16	635
K11 MS	542	603	332	91	540	508	G 4"	200	13	300	350	596	25	204	5	M8	390	16	640
K12 MS	548	606	332	91	540	508	G 4"	200	13	300	350	599	25	204	5	M8	390	13	645

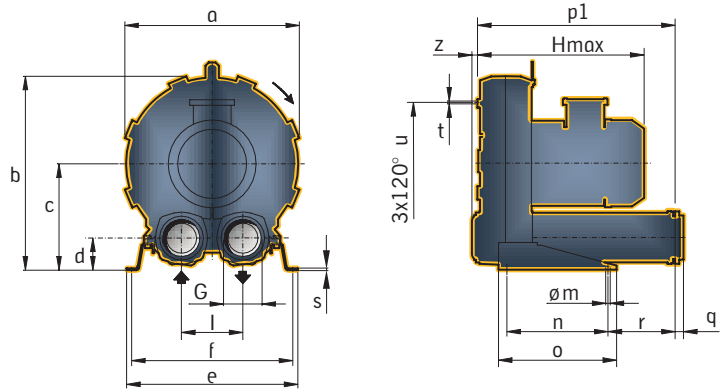

MD

K07R / K08R / K09 / K10 / K11 / K12  
R20 / R30 / R40

Mod	a	b	c	d	e	f	G	l	ø <sub>m</sub>	n	o	p1	q	r	s	t	u	z	Hmax*
K07R MD	424	481	269	82	470	438	G 2"	155	13	300	350	418	18	43	5	M8	295	16	450
K08R MD	457	498	269	82	480	448	G 2"	155	13	300	350	418	18	43	5	M8	310	16	485
K09MD	492	561	315	96	510	478	G 4"	182	13	300	350	644	25	257	5	M8	360	16	500
K10 MD	516	573	315	96	510	478	G 4"	182	13	300	350	644	25	257	5	M8	360	16	590
K11 MD	542	603	332	91	540	508	G 4"	200	13	300	350	654	25	262	5	M8	390	16	640
K12 MD	548	606	332	91	540	508	G 4"	200	13	300	350	657	25	262	5	M8	390	13	645
R20 MD	283	309	167	47	235	210	G 1" 1/4	90	10	150	200	345	18	45	22	M6	150	-	340
R30 MD	319	346	187	47	235	210	G 1" 1/4	90	10	150	200	354	18	45	22	M6	180	-	390
R40 MD	350	372	197	47	235	210	G 1" 1/4	90	10	150	200	364	18	45	22	M8	225	-	440

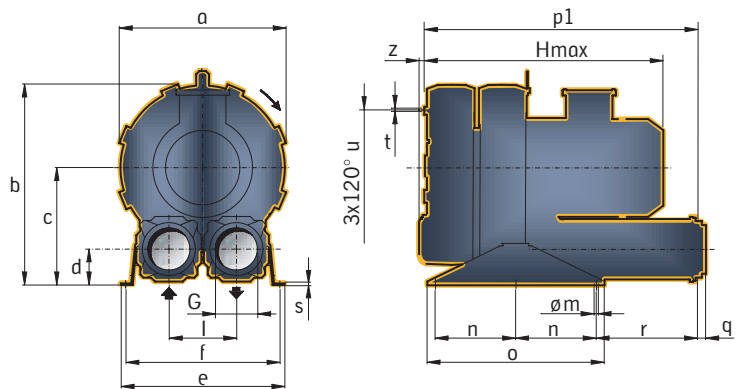

TS

K05 / K05-66 / K06 / K07  
K08 / K09 / K10 / K11 / K12

Mod	a	b	c	d	e	f	G	l	ø <sub>m</sub>	n	o	p1	q	r	s	t	u	z	Hmax*
K05 TS	327	422	258	77	404	374	G 3"	150	13	300	345	634	25	328	4	M8	200	19	500
K05-66 TS	327	365	200	54	325	290	G 2"	120	15	140	265	428	340	18	85	4	M8	200	495
K06 TS	376	455	267	75	404	374	G 3"	155	13	150	345	662	25	335	4	M8	240	19	585
K07 TS	424	531	319	98	470	438	G 4"	182	13	250	550	802	25	299	5	M8	295	16	620
K08 TS	457	548	319	98	480	448	G 4"	182	13	250	550	802	25	299	5	M8	310	16	620
K09 TS	492	610	365	112	510	478	G 5"	210	13	250	550	850	35	315	5	M8	360	16	790
K10 TS	516	623	365	112	510	478	G 5"	210	13	250	550	850	35	315	5	M8	360	16	790
K11 TS	542	650	380	106	540	508	G 5"	228	13	250	550	870	35	320	5	M8	390	16	805
K12 TS	548	653	380	106	540	508	G 5"	228	13	250	550	883	35	320	5	M8	390	13	820

# SIDE CHANNEL BLOWERS

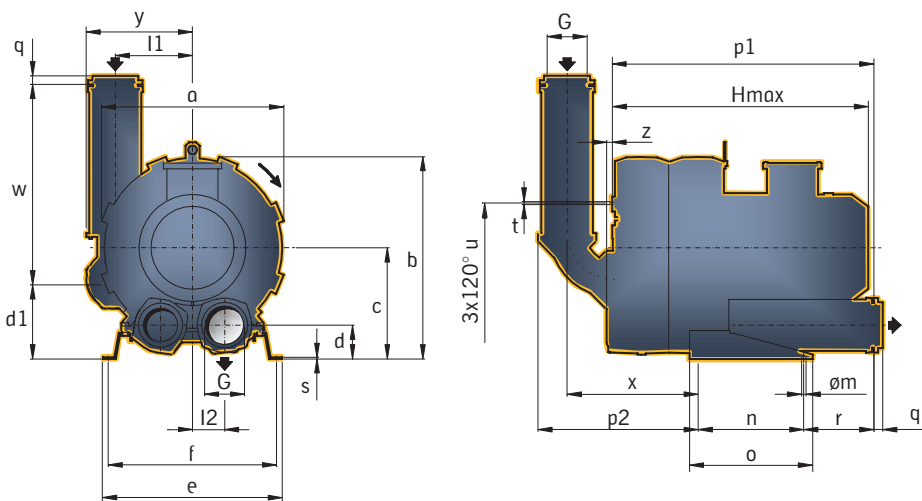

TD

K04 / K05 / K06 / K07 / K08 /  
K09 / K10 / K11 / K12

Mod	a	b	c	d	e	f	G	l1	l2	øm	n	o	p1	p2	q	r	s	t	u	w	x	y	z	Hmax*
K04-TD	285	315	172	49	255	225	G 1" 1/2	123	51	12	95	171	316	254	18	70	4	M6	175	188	214	173	18	440
K05-TD	327	365	200	54	325	260	G 2"	145	60	15	115	265	428	340	18	98	4	M8	200	285	293	206	19	500
K06-TD	376	420	232	59	325	290	G 2"	151	73	15	140	265	508	354	18	136	4	M8	240	285	308	210	19	585
K07-TD	424	481	269	82	470	438	G 3"	187	77.5	13	300	350	650	392	25	137	5	M8	295	481	319	260	16	620
K08-TD	457	498	269	82	480	448	G 3"	187	77.5	13	300	350	650	392	25	137	5	M8	310	481	319	260	16	620
K09-TD	492	561	315	96	510	478	G 4"	220	91	13	300	350	745	455	25	199	5	M8	360	556	372	302	16	790
K10-TD	516	573	315	96	510	478	G 4"	220	91	13	300	350	745	455	25	199	5	M8	360	556	372	302	16	790
K11-TD	542	603	332	91	540	508	G 4"	242	100	13	300	350	765	470	25	204	5	M8	390	556	387	324	16	805
K12-TD	548	606	332	91	540	508	G 4"	242	100	13	300	350	778	483	25	204	5	M8	390	556	400	324	13	820

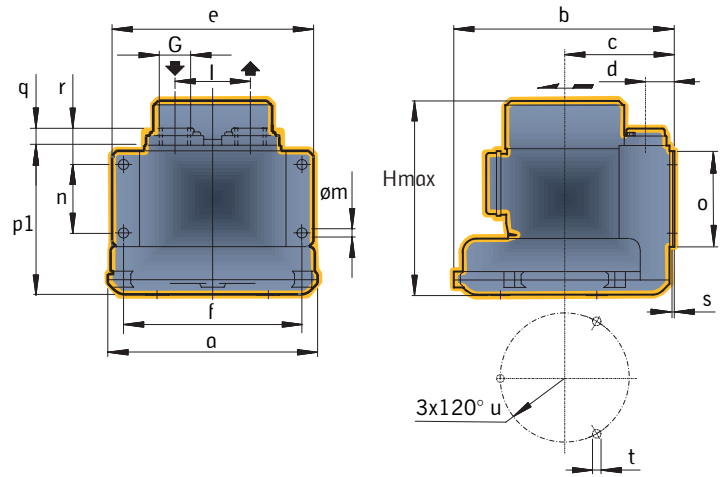

06-MS

Mod	a	b	c	d	e	f	G	l	ø <sub>m</sub>	n	o	p <sub>1</sub>	q	r	s	t	u	H <sub>max</sub>
06-MS	222	234	116	30	220	195	G 1"	80	11	75	105	160	15	35	2	M5	136	235

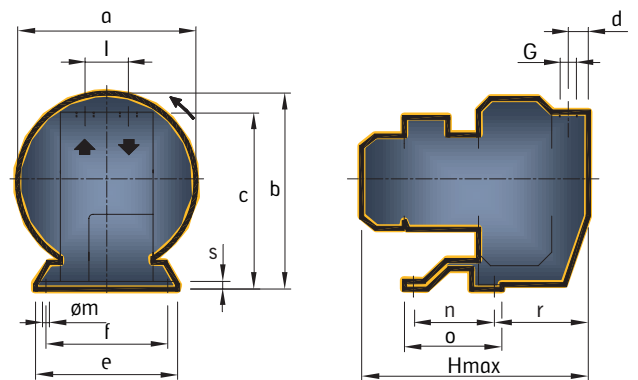

10DL-MD / 15DH-MD

Mod	a	b	c	d	e	f	G	l	ø <sub>m</sub>	n	o	r	s	H <sub>max</sub>
10 DL-MD	220	256	230	23	210	180	G 1/2"	58	9	120	144	90	2,5	300
15 DH-MD	250	286	258	30	210	180	G 3/4"	64	9	120	144	120	2,5	335

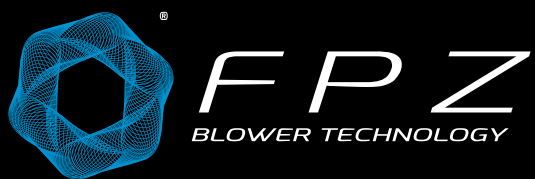

# *SIDE CHANNEL BLOWERS*

*Accessories*

*Accessori*

*Accesorios*

[fpz.com](http://fpz.com)



# SIDE CHANNEL BLOWERS

ACCESSORIES FOR COMPRESSION - ACCESSORI IN COMPRESSIONE - ACCESORIOS EN COMPRESIÓN

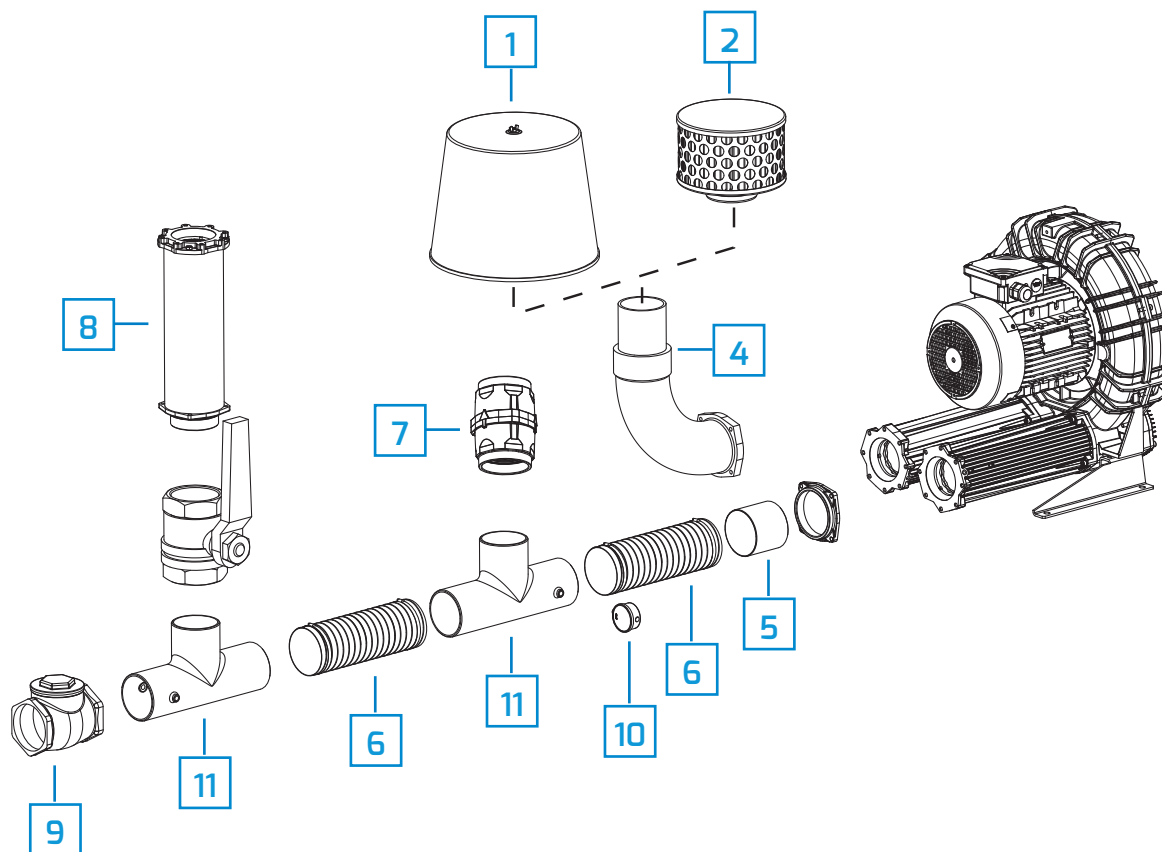

1 Cartridge filter - *Filtro a cartuccia* - Filtro Cartucho

2 Indoor intake filter - *Filtro di aspirazione per interni* - Filtro de aspiración para el interior

3 Cyclone filter - *Filtro a ciclone* - Filtro en línea

4 Filter manifold - *Collettore per filtri* - Colector

5 Hose sleeve - *Manicotto portagomma* - Bridas de unión

6 Flexible hose - *Manicotto flessibile* - Manguito flexible



ACCESSORIES FOR VACUUM - ACCESSORI IN ASPIRAZIONE - ACCESORIOS EN VACÍO

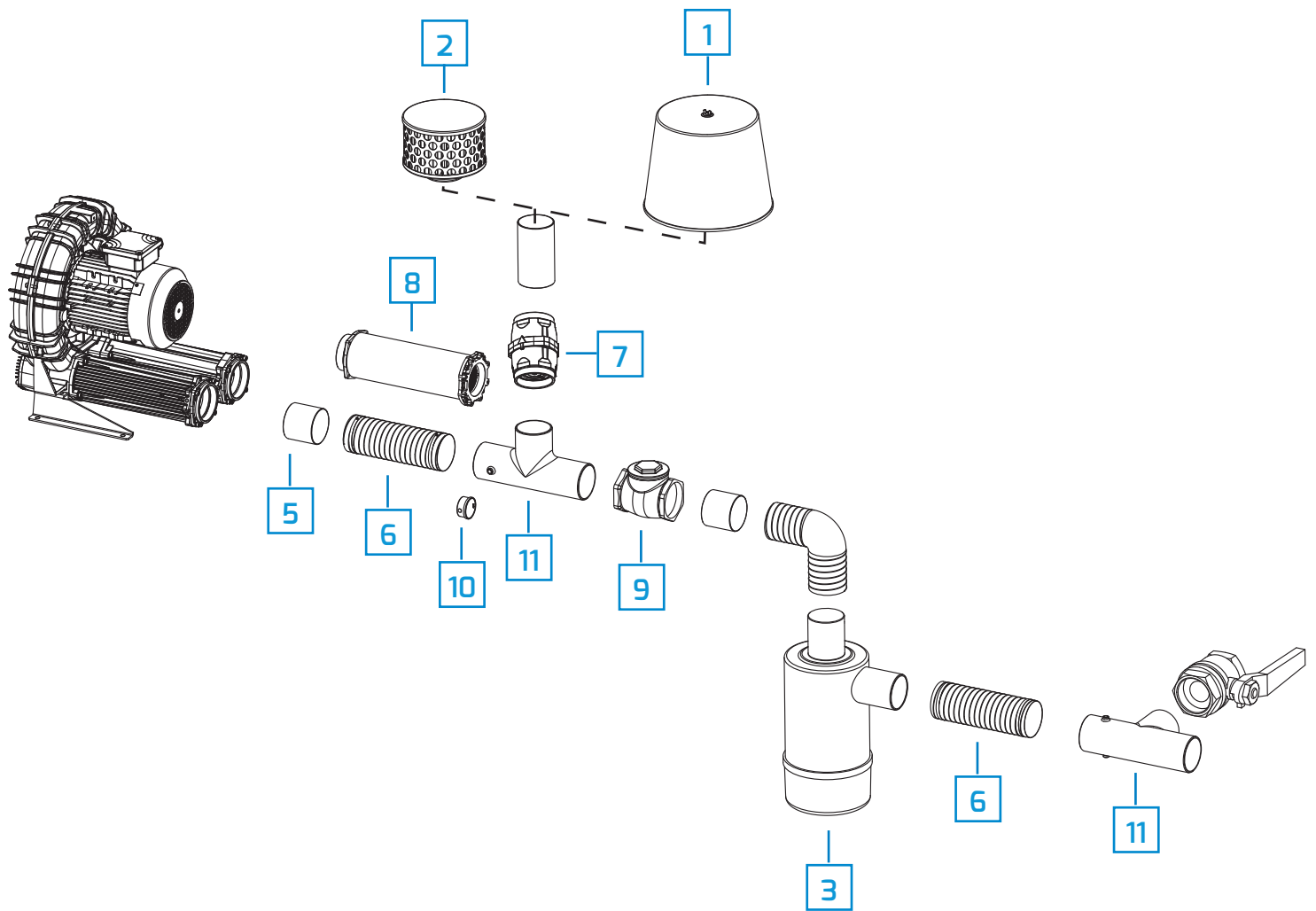

7 Vacuum/pressure relief valve - *Valvola limitatrice vuoto/pressione* - Válvula limitadora de vacío/presión

8 Additional silencer - *Silenziatore supplementare* - Silenciador adicional

9 Valve non return - *Valvola di non ritorno* - Válvula de retención

10 Pressure / Vacuum gauge - *Manometro / Vuotometro* - Manómetro / Vacuómetro

11 Relief valve/gauge holder - *Portavalvola VRL* - Porta Válvulas VRL

# SIDE CHANNEL BLOWERS

Indoor intake filter - *Filtro di aspirazione per interni* - Filtro de aspiración para el interior

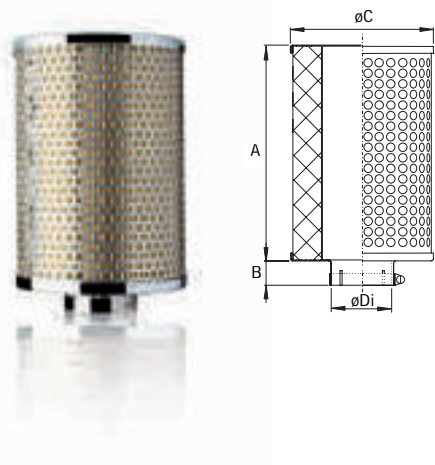

Mod	DN	A	B	øC	øDi	Flow Rate <i>Portata</i> Caudal [m <sup>3</sup> /h]	Weight <i>Peso</i> [kg]*
FA 4	32	126	23	126	43	100	0,63
FA 5	40	217	23	152	48.5	300	1,04
FA 6	50	217	23	152	61.5	400	1,00
FA 8	80	150	34	200	89.5	700	1,38
FA 9	100	160	38	257	115.5	1400	2,27
FA 10	125	160	38	257	141	2800	2,20

Filter Element Material <i>Materiale Elemento Filtrante</i> Material del elemento filtrante	Degree of Filtration - Nominal <i>Grado di Filtrazione Nominale</i> Grado de filtración nominal [µm]
Paper - <i>Carta</i> - Papel	25
Polyester - <i>Poliestere</i> - Poliéster	10
Stainless steel - INOX	60

\* Standard version filter/cartridge dimensions and characteristic data  
 \* *Ingombri e dati caratteristici del filtro/cartuccia in versione standard*  
 \* Dimensiones y datos característicos del filtro/cartucho en versión estándar

Inline filter - *Filtro in linea* - Filtro en línea



Mod	DN	A	øB	C	E	Gi	Ge	M	Flow Rate <i>Portata</i> Caudal [m <sup>3</sup> /h]	Weight <i>Peso</i> [kg]*
FV 5	40	196	176	100	112	G 1" 1/2	-	-	180	2,10
FV 6	50	255	200	115	131	G 2"	-	-	280	4,65
FV 8	80	270	200	125	142	G 3"	-	-	700	3,44
FV 9	100	336	310	166	202	G 4"	-	-	750	7,15
FV 10	125	690	470	265	495	-	G 5"	40	2450	54,00

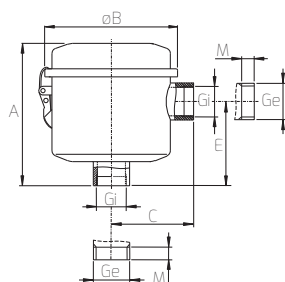

Mod	Filter / <i>Filtro</i> / Filtro	øe	h	Weight / <i>Peso</i> [kg]*
CV 5	FV 5	125	155	0,53
CV 6	FV 6 FV 8	150	215	0,87
CV 9	FV 9	234	276	0,50
CV 10	FV 10	250	240	1,60

Filter Element Material <i>Materiale Elemento Filtrante</i> Material del elemento filtrante	Degree of Filtration - Nominal <i>Grado di Filtrazione Nominale</i> Grado de filtración nominal [µm]
Paper - <i>Carta</i> - Papel	25
Polyester - <i>Poliestere</i> - Poliéster	10
Stainless steel - INOX	60

\* Standard version filter/cartridge dimensions and characteristic data  
 \* *Ingombri e dati caratteristici del filtro/cartuccia in versione standard*  
 \* Dimensiones y datos característicos del filtro/cartucho en versión estándar

Cartridge filter - Filtro a cartuccia - Filtro Cartucho

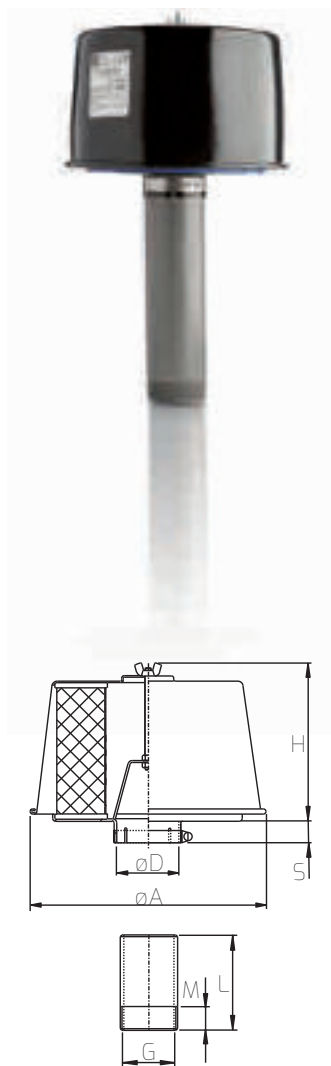

Mod	DN	øA	øD	H	S	G	L	M	Flow Rate Portata Caudal [m <sup>3</sup> /h]	Weight Peso [kg]*
FL 1	15	82	21,5	71	21	G ½"	100	15	25	0,20
FL 2	20	150	27	107	22	G ¾"	130	15	85	0,60
FL 3	25	150	34	107	16	G 1"	140	15	85	0,62
FL 4	32	150	43	107	17	G 1¼"	200	15	85	0,61
FL 5	40	203	48,5	153	14	G 1½"	200	15	250	1,32
FL 6	50	220	61,5	159	17	G 2"	200	15	400	1,56
FL 8	80	290	89,5	184	35	G 3"	200	20	700	2,60
FL 9	100	410	115,5	335	35	G 4"	200	20	1400	6,75
FL 10	125	410	141	335	35	G 5"	200	30	2800	6,70

Mod	Filter / Filtro / Filter	øe	øi	h	Weight / Peso [kg]*
CF 1	FL 1	55	25	54	0,05
	FL 2				
CF 4	FL 3	108	55	82	0,20
	FL 4				
CF 5	FL 5	147	80	135	0,43
CF 6	FL 6	176	80	135	0,60
CF 8	FL 8	225	100	155	1,00
CF 9	FL 9	300	215	303	1,90
	FL10				

Filter Element Material Materiale Elemento Filtrante Material del elemento filtrante	Degree of Filtration - Nominal Grado di Filtrazione Nominale Grado de filtración nominal [µm]
Paper - Carta - Papel	25
Polyester - Poliestere - Poliéster	10
Stainless steel - INOX	60

\* Standard version filter/cartridge dimensions and characteristic data  
 \* Ingombri e dati caratteristici del filtro/cartuccia in versione standard  
 \* Dimensiones y datos característicos del filtro/cartucho en versión estándar

Section - Tronchetto - Tubo

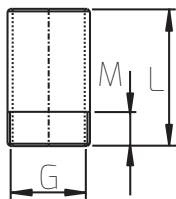

Mod	DN	G	L	M	Weight / Peso [kg]
TR 1	15	G ½"	100	15	0,02
TR 2	20	G ¾"	130	15	0,04
TR 3	25	G 1"	140	15	0,06
TR 4	32	G 1¼"	200	15	0,14
TR 5	40	G 1½"	200	15	0,16
TR 6	50	G 2"	200	15	0,22
TR 8	80	G 3"	200	20	0,39
TR 9	100	G 4"	200	20	0,50
TR 10	125	G 5"	200	30	1,23

# SIDE CHANNEL BLOWERS

## Cyclone filter - Filtro a ciclone - Filtro "ciclón"



Mod	DN	øB	C	øD	E	G	H	L	M	Flow Rate Portata Caudal [m³/h]	Weight Peso [kg]
FC 5	40	146	130	48	126	G 1" 1/2	315	83	22	170	2,37
FC 6	50	178	156	60	140	G 2"	341	90	22	240	3,39
FC 8	80	220	157	88	174	G 3"	453	102	22	440	5,24
FC 9	100	276	225	114	204	G 4"	493	123	22	730	9,14

Mod	Filter / Filtro	øe	h	Weight / Peso [kg]*
CL 5	FC 5	104	264	0,51
CL 6	FC 6	134	290	0,93
CL 8	FC 8	155	395	1,50
CL 9	FC 9	202	421	2,11

Filter Element Material Materiale Elemento Filtrante Material del elemento filtrante	Degree of Filtration - Nominal Grado di Filtrazione Nominale Grado de filtración nominal [µm]
Paper - Carta - Papel	25
Polyester - Poliestere - Poliéster	10

\* Standard version filter/cartridge dimensions and characteristic data  
 \* Ingombri e dati caratteristici del filtro/cartuccia in versione standard  
 \* Dimensiones y datos característicos del filtro/cartucho en versión estándar

## Bracket - Staffa - Soporte

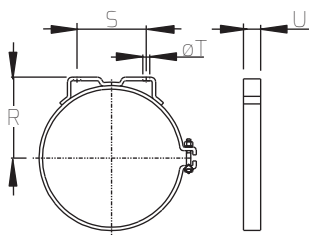

Mod	Filter / Filtro	R	S	øT	U
FS 5	FC 5	70	84	9	22
FS 6	FC 6	103	93	9	22
FS 8	FC 8	122	112	9	25
FS 9	FC 9	147	126	11.5	32

## Intake protection - Protezione in aspirazione - Protección en aspiración

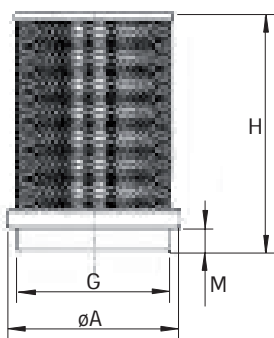

Mod	DN	øA	G	H	M	Degree of Filtration Grado di Filtrazione Grado de Filtración	Weight Peso [g]
IP4	32	50	G 1" 1/4	75	10	1200 µm	38
IP5	40	56	G 1" 1/2	83	11	1200 µm	47
IP6	50	69	G 2"	98	13	1200 µm	70
IP8	80	102	G 3"	138	15	2000 µm	194
IP8 N	80	102	3" NPT	138	15	2000 µm	194
IP9	100	129	G 4"	153	16	2000 µm	300
IP9 N	100	129	4" NPT	153	16	2000 µm	300

Filter manifold - Collettore per filtri - Colector



Mod	DN	A	B	øD	I	M	R	S	γ	Fig	Weight Peso [kg]
CA 4	32	220	90	42	75	7	80	15	30°	1	0,22
CA 4V	32	220	90	42	64	7	80	15	-	2	0,22
CA 4K	32	260	160	42	64	7	80	15	-	2	0,32
CA 5	40	260	110	48	85	7	100	15	45°	1	0,43
CA 5V	40	260	110	48	75	7	100	15	-	2	0,43
CA 5K	40	300	180	48	75	7	100	15	-	2	0,55
CA 6	50	320	135	60	85	7	126	15	45°	1	0,73
CA 6V	50	320	135	60	85	7	126	15	-	2	0,73
CA 8	80	380	185	88,5	120	7	180	15	-	3	1,60
CA 9	100	400	235	113,9	150	9	220	20	-	3	3,14
CA 10	125	450	300	140	210	18	280	20	-	3	5,88

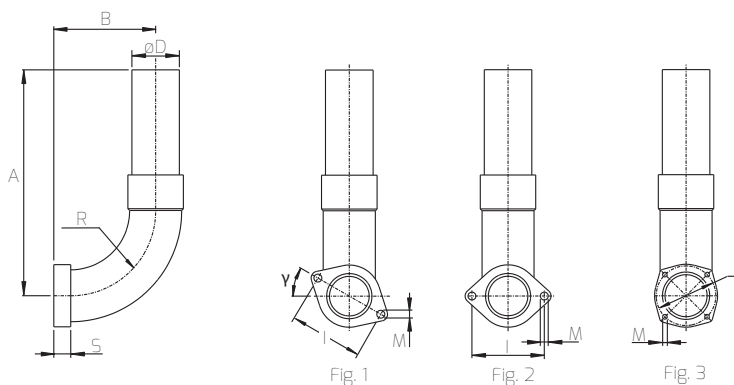

CK Manifold - Collettore CK - Colector CK



Mod	DN	A	B	øC	øD	E	E1	F	4xG	4xG1	I	I1	I2	I3	I4	Weight Peso [kg]
CK 4	32	69	84,6	-	38	11,5	7,0	56	M6	7	-	14,5	14,5	70,2	70,2	0,36
CK 5	40	80	100	-	43	11,5	7,0	56	M6	7	-	17,6	17,6	85	85	0,50
CK 6	50	92	118	-	55	13,0	8,5	69	M8	9	-	18,3	23,8	99,4	104	0,70
CK 8	80	-	-	145	75	10,5	10,5	110	M8	9	130	-	-	-	-	1,37
CK 9	100	-	-	165	90	10,5	10,5	132	M8	9	150	-	-	-	-	1,77
CK 10	125	-	-	220	128	10,5	10,5	192	M8	9	190	-	-	-	-	3,82

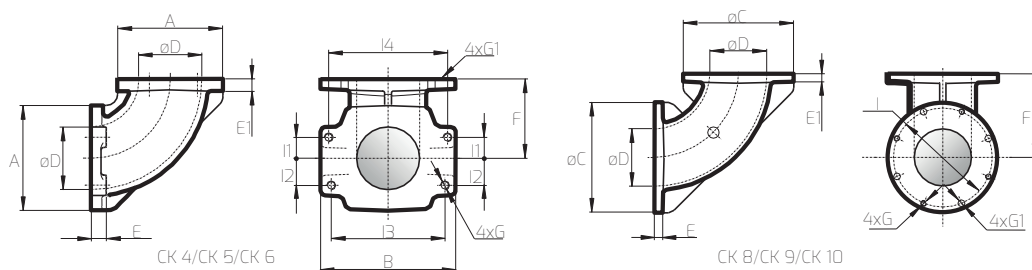

# SIDE CHANNEL BLOWERS

Hose flange for blower K - PK - *Flangia portagomma per SCL K - PK* - Brida portagoma para SCL K - PK



Mod	DN	øD	H	I	L	R	S	Fig	Weight Peso [g]
PK 5	40	48	30	92	20	6,5	10	1	90
PK 6	50	60	50	110	35	8,5	10	1	270
PK 6A	50	60	60	130	35	9	11	2	335
PK 8	80	88	43	130	24	9	11	2	300
PK 9	100	113	46	150	27	9	11	2	385

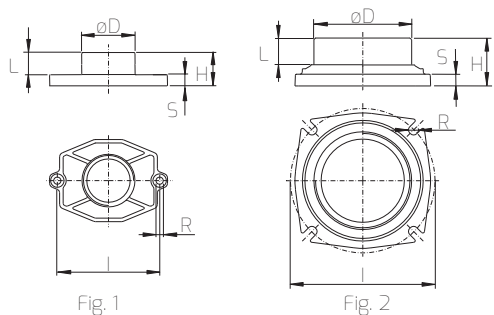

Hose sleeve - *Manicotto portagomma* - Bridas de unión



Mod	DN	øD	G	H	I	L	M	R	S	Fig	Weight Peso [kg]
MP 1	15	21	G 1/2"	100	-	85	-	-	-	4	0,10
MP 2	20	27	G 3/4"	100	-	85	-	-	-	4	0,12
MP 3	25	32	-	35	54,5	25	-	6,5	-	1	0,06
MP 4	32	42	-	35	75	25	-	6,5	-	1	0,07
MP 4V	32	42	-	35	64	25	-	6,5	-	1	0,07
MP 5	40	48	-	35	85	25	-	6,5	-	1	0,10
MP 5V	40	48	-	35	75	25	-	6,5	-	1	0,10
MP 6	50	60	-	35	85	25	-	6,5	-	1	0,12
MP 8	80	88	-	45	120	32	-	6,5	-	2	0,24
MP 9	100	114	G 4"	100	-	80	-	-	-	4	0,88
MP 10	125	140	-	62	210	52	-	17	-	2	2,40
MP 10G	125	-	G 5"	62	210	-	35	17	10	3	2,40
MP 10N	125	-	5"NPT	62	210	-	35	17	10	3	2,40

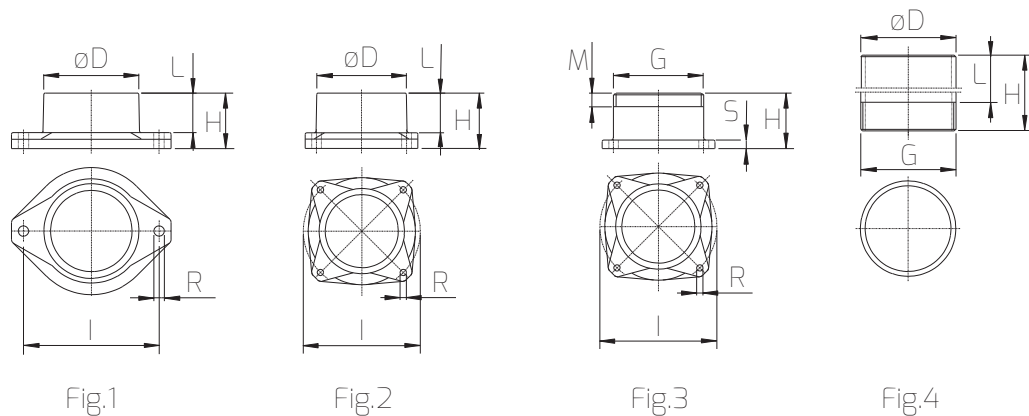

Flexible hose - Manicotto flessibile - Manguito flexible

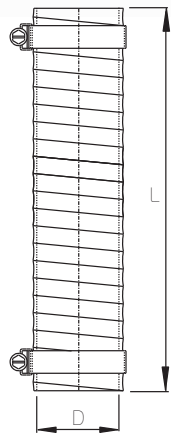

Mod	DN	D	L
FM 1	15	22	200
FM 2	20	30	200
FM 3	25	32	200
FM 4	32	45	200
FM 4C	32	45	110
FM 5	40	51	250
FM 5C	40	51	130
FM 6	50	64	250
FM 6C	50	64	135
FM 8	80	90	330
FM 9	100	114	330
FM 10	125	140	330

Mod	Min. radius of curvature Raggio di curvatura minimo Radio de curva mínima [mm]	Max pressure Pressione max Presión máx [bar]	Max negative pressure Depressione max Depresión máx [mbar]	Weight Peso [g]
FM 1	15	2,8	650	60
FM 2	15	2,8	650	65
FM 3	16	2,6	650	90
FM 4	21	2,6	560	135
FM 4C	21	2,6	560	85
FM 5	24	2,6	520	180
FM 5C	24	2,6	520	100
FM 6	31	2,4	480	200
FM 6C	31	2,4	480	120
FM 8	44	2,0	400	250
FM 9	57	1,6	290	370
FM 10	70	1,3	190	400

Flange for valves VRL - VK - Flangia per valvole VRL - VK - Brida para válvulas VRL - VK

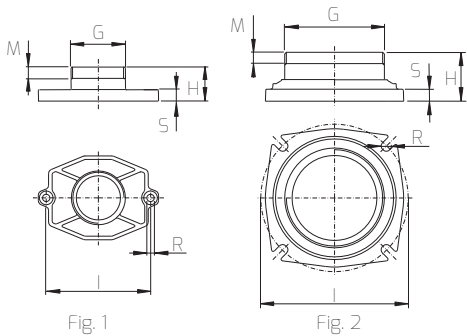

Mod	DN	G	H	I	M	R	S	Fig	Weight Peso [g]
VK 5G	40	G 2"	47	92	17	6.5	10	1	310
VK 6G	50	G 2"	50	110	17	8.5	10	1	265
VK 6AG	50	G 2"	60	130	12	9	11	2	345
VK 8G	80	G 3"	43	130	10	9	11	2	290
VK 9G	100	G 4"	46	150	12	9	11	2	360
VK 5N	40	1" 1/2 NPT	30	92	15	6.5	10	1	85
VK 6N	50	2" NPT	50	110	24	8.5	10	1	265
VK 6AN	50	2" NPT	60	130	19	9	11	2	345
VK 8N	80	3" NPT	44	130	20	9	11	2	280
VK 9N	100	4" NPT	46	150	23	9	11	2	345

# SIDE CHANNEL BLOWERS

Vacuum/pressure relief valve - Valvola limitatrice vuoto/pressione - Válvula limitadora de vacío/presión

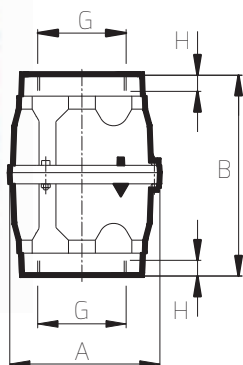

Mod	DN	A	B	G	H	Weight Peso [kg]
VRL 6 G	50	102	175	G 2"	12	0.89
VRL 6HP G	50	102	175	G 2"	12	0.89
VRL 8 G	80	135	190	G 3"	15	2.02
VRL 8HP G	80	135	190	G 3"	15	2.02
VRL 9 G	100	160	206	G 4"	18	2.81
VRL 6 N	50	102	175	2" NPT	12	0.89
VRL 6HP N	50	102	175	2" NPT	12	0.89
VRL 8 N	80	135	190	3" NPT	15	2.02
VRL 8HP N	80	135	190	3" NPT	15	2.02
VRL 9 N	100	160	206	4" NPT	18	2.81

Additional silencer - Silenziatore supplementare - Silenciador adicional

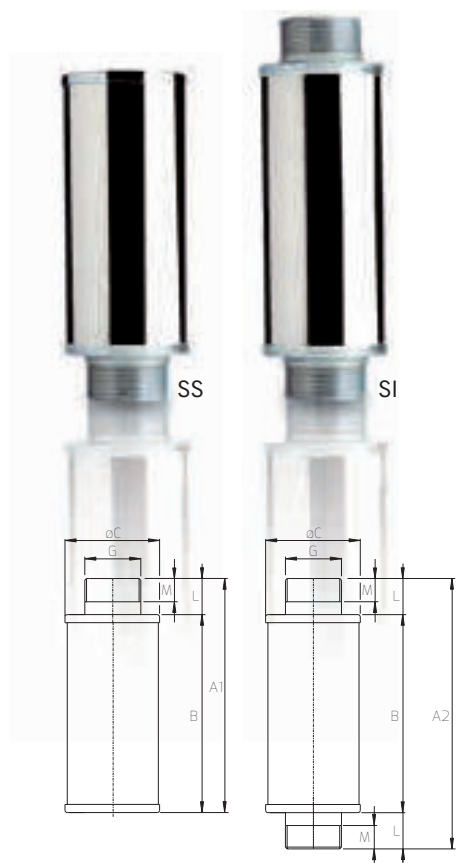

Mod	DN	A2	B	øC	G	L	M	Weight Peso [kg]
SI 4	32	240	140	70	G 1" 1/4	50	15	0,57
SI 5	40	230	170	80	G 1" 1/2	30	20	0,55
SI 6	50	260	200	90	G 2"	30	20	0,63
SI 8	80	570	400	152	G 3"	85	20	2,95
SI 9	100	485	430	169	G 4"	27	20	3,90
SI 9 N	100	485	430	169	4" NPT	27	20	3,90

Mod	DN	A1	B	øC	G	L	M	Weight Peso [kg]
SS 4	32	190	140	70	G 1" 1/4	50	15	0,38
SS 5	40	200	170	80	G 1" 1/2	30	20	0,44
SS 6	50	230	200	90	G 2"	30	20	0,50
SS 8	80	485	400	152	G 3"	85	20	2,04
SS 9	100	465	430	169	G 4"	27	20	4,10
SS 9 N	100	465	430	169	4" NPT	27	20	4,10



Threaded flange TF - Flangia filettata TF - Brida roscada TF

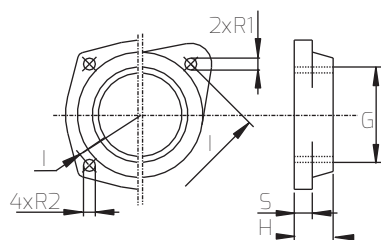

Mod	DN	G	H	I	2xR1	4xR2	S	Weight Peso [g]
TF 3 G	25	G 1"	18	54,5	6,5	-	10	47
TF 4 G	32	G 1" 1/4	18	75	6,5	-	10	95
TF 4V G	32	G 1" 1/4	18	64	6,5	-	10	50
TF 5 G	40	G 1" 1/2	18	85	6,5	-	10	130
TF 5V G	40	G 1" 1/2	18	75	6,5	-	10	80
TF 6 G	50	G 2"	18	85	6,5	-	10	100
TF 8 G	80	G 3"	25	120	-	6,5	13	200
TF 9 G	100	G 4"	25	150	-	9	13	285
TF 10 G	125	G 5"	35	210	-	17	13	770
TF 3 N	25	1" NPT	18	54,5	6,5	-	10	47
TF 4 N	32	1" 1/4 NPT	18	75	6,5	-	10	95
TF 4V N	32	1" 1/4 NPT	18	64	6,5	-	10	50
TF 5 N	40	1" 1/2 NPT	18	85	6,5	-	10	130
TF 5V N	40	1" 1/2 NPT	18	75	6,5	-	10	80
TF 6 N	50	2" NPT	18	85	6,5	-	10	100
TF 8 N	80	3" NPT	25	120	-	6,5	13	200
TF 9 N	100	4" NPT	25	150	-	9	13	285
TF 10 N	125	5" NPT	35	210	-	17	13	770

Relief valve/gauge holder - Porta valvola/manometro - Porta válvula / manómetro



Mod	DN	A	B	C	2xG	G1	G2	M1	M2	S	Weight Peso [kg]
PV 56	40	325	95	83	G 1/4"	G 1" 1/2	G 2"	15	21,5	40	1,73
PV 66	50	227	95	35	G 1/4"	G 2"	G 2"	21,5	21,5	40	0,85
PV 86	80	310	135	55	G 1/4"	G 3"	G 2"	28,0	21,5	54	1,85
PV 88	80	310	130	55	G 1/4"	G 3"	G 3"	28,0	28,0	54	1,99
PV 96	100	370	150	65	G 1/4"	G 4"	G 2"	31,5	21,5	67	2,64
PV 98	100	370	173	65	G 1/4"	G 4"	G 3"	31,5	28,0	67	3,00
PV 99	100	370	147	65	G 1/4"	G 4"	G 4"	31,5	31,5	67	2,80
PV 109	125	370	175	65	G 1/4"	G 5"	G 4"	31,5	31,5	80	4,20

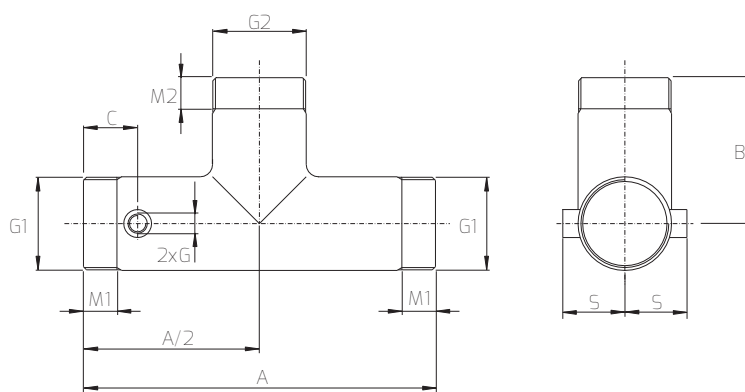

# SIDE CHANNEL BLOWERS

Non return valve - Valvola di non ritorno - Válvula de retención

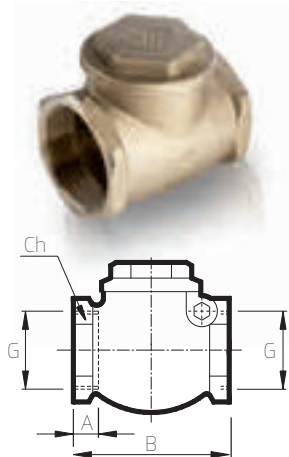

Mod	DN	A	B	G	Ch Hex Ch Esagono Ch Hexágono	Weight Peso [kg]
VC 1	15	8	47	G 1/2"	25	0,16
VC 2	20	8	53	G 3/4"	32	0,33
VC 3	25	10	63	G 1"	38	0,38
VC 4	32	10	74	G 1" 1/4	47	0,46
VC 5	40	10	87	G 1" 1/2	55	0,74
VC 6	50	11	97	G 2"	67	1,02
VC 8	80	16	135	G 3"	95	2,44
VC 9	100	20	164	G 4"	124	3,90
VC 10	125	22	206	G 5"	150	6,97

Ball valve - Valvola a sfera - Válvula de bola

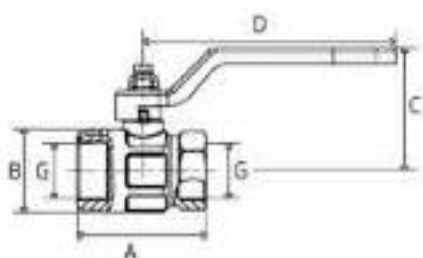

Mod	DN	A	B	C	D	G	Weight Peso [g]
VM 3	25	70	45,5	59	113	G 1"	0,42
VM 4	32	80,5	57	75	138	G 1" 1/4	0,68
VM 5	40	94,5	70	81	138	G 1" 1/2	1,03
VM 6	50	112,5	84	96	157,8	G 2"	1,63

Vacuum/pressure relief valve - Valvola limitatrice vuoto/pressione - Válvula limitadora de vacío/presión



Mod	DN	G	H	Weight Peso [g]
RV 3	25	G 1"	57	70
VLA 3	25	G 1"	57	70

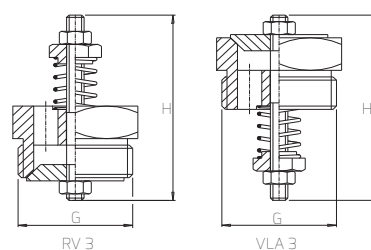

Pressure / Vacuum gauge - Manometro / Vuotometro - Manómetro / Vacuómetro



Mod	$\Delta p$ mbar	Accuracy Precisione Precisión	DN	B	C	E	G	M	Weight Peso [g]
MC 040	0÷600	1,6%	63	27	10	54	G 1/4"	13	99
MC 050	0÷1000	1,6%	63	27	10	54	G 1/4"	13	99
MV 020	-600÷0	1,6%	63	27	10	54	G 1/4"	13	99

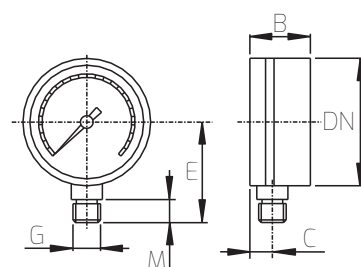

Acoustic hood - Cabina afona - Cabina de insonorización

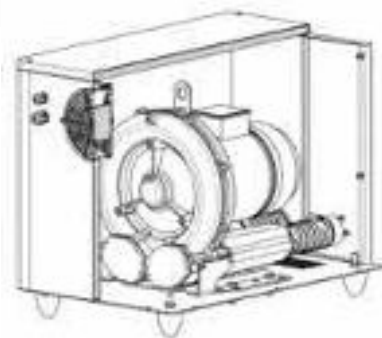

Mod	A	B	C	X SCL
IH 1	340	462	400	K03-MS MOR
IH 3	363	500	420	K04-MS MOR
IH 4	430	680	540	R20/R30/R40-MD MOR
IH 5	430	680	540	K05/K06-MS MOR

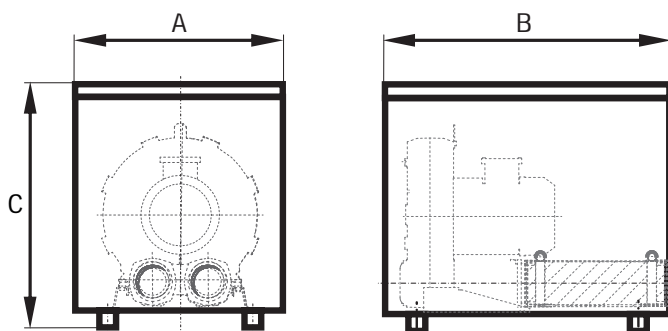

A careful check of the accessories datasheet is appreciated. Ask your sales contact.  
 E' gradito un accurato controllo del datasheet accessori.  
 Chiedere al vostro commerciale di riferimento.  
 Se ruego controlar a fondo la ficha técnica des accesorios.  
 Solicite información a su comercial de referencia.



Mod	A	B	C	X SCL
IH 7	805	1635	660	K07/K75/K08-MS MOR
IH 7R	805	1635	660	K07R/K08R-MD MOR
IH 8	805	1635	660	K07/K08-TD MOR
IH 9	805	1635	660	K07/K08-TS MOR
IH 10	805	1705	760	K09/K10/K11/K12-MS/MD MOR
IH 11	805	1705	760	K09/K10-TD MOR
IH 12	805	1705	760	K11/K12-TD MOR
IH 13	805	1705	800	K09/K10/K11/K12-TS MOR

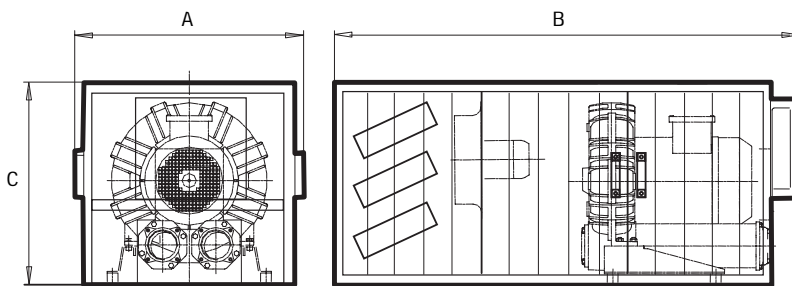

A careful check of the accessories datasheet is appreciated. Ask your sales contact.  
 E' gradito un accurato controllo del datasheet accessori.  
 Chiedere al vostro commerciale di riferimento.  
 Se ruego controlar a fondo la ficha técnica des accesorios.  
 Solicite información a su comercial de referencia.

# SIDE CHANNEL BLOWERS

VS SERIES FLOW REVERSING VALVE - VALVOLA INVERSIONE DI FLUSSO SERIE VS - VÁLVULA DE INVERSIÓN DEL FLUJO SERIE VS

The "VS" flow reversing valve is a device that operates by means of a sliding selector that, in approximately one tenth of a second, can switch the direction of the flow or the exchange of the pipe towards which the flow is conveyed. Built simply and entirely from aluminium alloy, it is not subject to contacts and/or interference between the selector and the valve body. This product is available with 24VDC or 110V/60 Hz and 220V 50/60hz electrical control or with pneumatic control (0.2 litres per cycle air consumption). The 'VS' valve is also available in 5 versions with the option of GAS/NPT flange attachment or hose sleeve.

*La valvola di inversione del flusso tipo "VS" è un dispositivo che agisce mediante un selettore traslante che consente - in 0,10 sec. ca - la commutazione del verso del flusso oppure lo scambio della condotta a cui il flusso è convogliato. Interamente costruito in lega di alluminio e di semplice costruzione, non è soggetto a contatti e/o interferenze tra il selettore ed il corpo valvola. Questo prodotto è disponibile con comando elettrico 24v c.c. oppure 110V/60hz e 220V 50/60 hz oppure pneumatico (consumo aria 0,02 litri/ciclo). La valvola "VS" è altresì disponibile in 5 versioni con possibilità di attacco flangiato GAS/NPT o con manicotto portagomma.*

La válvula de inversión del flujo tipo "VS" es un dispositivo que opera por medio de un selector de traslación que permite (en 0,10 seg. aprox.) la conmutación de la dirección del flujo o el cambio del conducto en el que se transporta el flujo. La misma está enteramente construida en aleación de aluminio, su diseño es simple, no está sujeto a contactos y/o interferencias entre el selector y el cuerpo de la válvula en cuestión. Este producto está disponible con control eléctrico 24vcc o 110Vca 60Hz y 220Vca 50/60 Hz o neumático (consumo de aire 0,02 litros/ciclo). La válvula "VS" también está disponible en 5 versiones con la posibilidad de conexión con bridas GAS/NPT o con conexión para manguito.



VI SERIES FLOW REVERSING VALVE - VALVOLA INVERSIONE DI FLUSSO SERIE VI - VÁLVULA DE INVERSIÓN DE FLUJO SERIE VI

The "VI" flow reversing valve is used as an accessory for side channel blowers to switch the flow from pressure to negative pressure and vice versa. The flow reversing valve is:

- Designed and built in accordance with Machinery Directive 2006/42/EC.
- Made of aluminium alloy.
- Suitable for conveying air and non-explosive, non-flammable, non-aggressive gases in a non-explosive atmosphere, in continuous service.
- It can be installed on SCL K04-MS / MS-K05 / K06-MS only in a vertical arrangement.

*La valvola di inversione del flusso tipo "VI" è un dispositivo impiegato come accessorio per le soffianti a canale laterale per la commutazione del flusso da pressione a depressione e viceversa. La valvola di inversione di flusso:*

- È progettata e costruita in accordo alla Direttiva Macchine 2006/42/CE.
- È realizzata in lega di alluminio.
- È adatta a canalizzare, aria e gas non esplosivi, non infiammabili, non aggressivi in atmosfera non esplosiva, in servizio continuo.
- Può essere installata sulle SCL K04-MS / K05-MS / K06-MS solo in esecuzione verticale.

La válvula de inversión de flujo tipo "VI" es un dispositivo que se utiliza como accesorio para los Soplantes de Canal Lateral para la conmutación del flujo de presión a depresión y viceversa. La válvula de inversión de flujo:

- Está diseñada y construida de acuerdo con la Directiva de Máquinas 2006/42/CE.
- Su cuerpo está construido de una aleación de aluminio.
- Es adecuada para encauzar, aire y gases no explosivos, no inflamables, no agresivos en atmósfera no explosiva, en servicio continuado.
- Puede ser instalada en los soplantes SCL K04-MS / MS-K05 / K06-MS de flujo vertical





# SIDE CHANNEL BLOWERS

*Special machines*

*Macchine speciali*

*Máquinas especiales*

Vertical coupling  
*Giunto verticale*  
Acoplamiento vertical

fpz.com



Versatility and flexibility: two concepts that are reflected in our special versions. In addition to the standard side channel blowers, FPZ has also designed special configurations that allow the machine to adapt to different fields.

- We designed blowers with a coupling suitable for **horizontal or vertical installation** (GOR-GVR) Eex(d), IE2, IE3, cURus, NEMA and ATEX motors.
- FPZ manufactures blowers with a double mechanical seal (TMD) for conveying hazardous fluids such as methane, biogas and technical gases.
- If you have to install your own motor, you can request blowers with **bare shaft** or **flexible joint**.
- When blowers are used in areas that require greater protection of mechanical parts or when the materials must have good oxidation resistance due to the operating environment or the gas conveyed, FPZ offers side channel blowers with **anodised and impregnated parts in contact with the fluid**.
- If blowers are used to compress or draw air/gas for which a better containment of the gas conveyed must be ensured and/or a good resistance to oxidation of the materials is needed due to the external environment or to the gas conveyed, FPZ manufactures **TMS** blowers.

*Versatilità e flessibilità: due concetti che si rispecchiano nelle nostre versioni speciali. Oltre alle soffianti a canale laterale standard infatti FPZ ha progettato anche configurazioni speciali che consentono alla macchina di adattarsi ai più svariati settori.*

- *Abbiamo progettato soffianti con lanterna adatta per l'installazione **orizzontale o verticale** (GOR-GVR) di motori Eex(d), IE2, IE3, cURus, NEMA, ATEX.*
- *FPZ produce soffianti con una doppia tenuta meccanica (TMD) per il convogliamento di **fluidi pericolosi** tipo metano, biogas e gas tecnici.*
- *In caso di necessità di installazione di un proprio motore è possibile richiedere soffianti ad **asse nudo** o dotate di **giunto flessibile***
- *Quando le soffianti sono utilizzate in settori che richiedono una maggiore protezione delle parti meccaniche o quando i materiali devono avere una buona resistenza all'ossidazione dovuta all'ambiente operativo oppure al gas trasportato, FPZ offre soffianti a canale laterale con **anodizzazione ed impregnazione delle parti a contatto col fluido**.*
- *Nel caso in cui le soffianti vengano utilizzate per comprimere o aspirare aria/gas per cui si deve garantire un migliore contenimento del gas convogliato e/o sia necessaria una buona resistenza dei materiali all'ossidazione dovuta all'ambiente esterno oppure al gas trasportato, FPZ produce soffianti in versione **TMS**.*

Versatidad y flexibilidad: estos son los conceptos en las que se basan nuestras versiones especiales. Además de los Soplates de Canal Lateral estándar, FPZ también desarrolla configuraciones especiales que permiten que la máquina se adapte a los distintos sectores de aplicación.

- FPZ diseña soplantes con acople adecuado para la instalación **horizontal o vertical** (GOR-GVR) de los motores Eex(d), IE2, IE3, cURus, NEMA, ATEX.
- FPZ produce soplantes con doble sello mecánico (TMD) para el transporte de **gases peligrosos** como el metano, biogás o gases técnicos.
- Si se debe instalar un propio motor es posible solicitar soplantes con el **eje libre** y equipadas con **acoplamiento elástico**;
- Cuando los soplantes se utilizan en condiciones que requieren una mayor protección de las partes mecánicas o cuando los materiales deben tener una buena resistencia a la oxidación debido al entorno operativo o al gas transportado, FPZ ofrece Soplates de Canal Lateral con **las partes en contacto con el fluido anodizadas y/o tratadas superficialmente** según el caso.
- Si los soplantes se utilizan para comprimir o extraer aire/gas para lo cual se debe garantizar una mejor contención del gas transportado y/o se necesite una buena resistencia a la oxidación de los materiales debido al ambiente externo o al gas transportado, FPZ produce soplantes en la versión **TMS**.

Horizontal coupling  
*Giunto orizzontale*  
Acoplamiento horizontal



Direct drive  
*Monoblocco*  
Accionamiento directo



# SIDE CHANNEL BLOWERS

## ATEX versions

The range of products and components offered by FPZ also has a family of blowers designed to be used in **ATEX (ATMosphere Explosive)**, that is potentially explosive, environments belonging to group II, suitable for working in zone 1 and 2/22 Cat 2G, 3G and 3G/D.

These machines are also suitable for transporting **flammable fluids** such as natural gas, biogas and technical gases.

FPZ blowers ensure an adequate level of protection for both the systems designed for areas where the explosive atmosphere is likely to occur (**Category 2G**) and for those areas where the explosive atmosphere is less likely to occur (**category 3GD**).

Moreover, FPZ blowers belonging to category 2G and 2G/3G have been **certified by ICIM**, the Italian Certification Authority and Notified Body No. 0425 for the main European product-related directives. This is a further guarantee of the high quality and safety FPZ products offer.

## Use:

- Collection of biogas from landfills
- Gas pressure supply (flaring, burners and cogeneration plants)
- Gas extraction from tanks and equipment

## Versioni ATEX

La gamma di prodotti e componenti offerta da FPZ dispone anche di una famiglia di soffianti progettate per l'utilizzo in ambienti **ATEX (ATMosphere Explosive)**, ossia a rischio esplosione, appartenenti al gruppo II, idonee a lavorare in zona 1 e 2/22 Cat 2G, 3G e 3G / D.

Tali macchine sono idonee anche per il trasporto di **fluidi infiammabili** come metano, biogas e gas tecnici.

Le soffianti FPZ garantiscono un adeguato livello di protezione sia per i sistemi destinati a zone dove è probabile la formazione di atmosfera esplosiva (**categoria 2G**) sia per quelle zone dove è meno probabile la formazione di atmosfera esplosiva (**categoria 3GD**).

In aggiunta, le soffianti FPZ appartenenti alla categoria 2G e 2G/3G sono state **certificate presso ICIM**, Ente di Certificazione italiano e Organismo Notificato n°0425 per le principali Direttive europee di prodotto. Ciò ad ulteriore garanzia dell'elevata qualità e sicurezza fornita dai prodotti FPZ.

## Utilizzo:

- Captazione di biogas da discariche
- Alimentazione in pressione del gas (combustione in torcia, bruciatori e impianti di cogenerazione)
- Aspirazione gas da serbatoi e impianti

## Versiones ATEX

La gama de productos y componentes ofrecidos por FPZ también tiene una familia de soplantes diseñados para su uso en entornos **ATEX (ATMosphere Explosive)**, es decir potencialmente explosivos, pertenecientes al grupo II, y aptos para operar en la zona 1 y 2/22 Cat. 2G, 3G y 3G/D.

Estas máquinas también son adecuados para el transporte de **gases inflamables**, tales como el metano, biogás y gases técnicos.

Los soplantes FPZ garantizan un nivel adecuado de protección de los sistemas diseñados para áreas en las que es probable que se creen atmósferas explosivas (**Categoría 2G**) y para aquellas áreas donde es menos probable que la creen atmósferas explosivas (**Categoría 3GD**).

Por lo demás, los soplantes FPZ pertenecientes a la categoría 2G y 2G/3G están **certificados por ICIM**, Cuerpo de Certificación italiano y Organismo Notificado n° 0425 para las principales directivas europeas correspondientes. Esta es una garantía adicional de la alta calidad y la seguridad brindada por los productos de FPZ.

## Utilización:

- Captación del biogás emanado por vertederos
- Alimentación en presión de gas (combustión, quemadores y plantas de cogeneración)
- Extracción de gas de tanques y sistemas

## Full range of FPZ blowers with ATEX certificate

Gamma completa di soffianti FPZ con certificato ATEX

Gama completa de soplantes FPZ con certificación ATEX

Zone Zona Zona	Category Categoría Categoría	Environment Ambiente Medio ambiente	Protection mode (Ex) Modo di Protezione (Ex) Modo de Protección (Ex)	Sub-groups Sotto Gruppi Sub Grupos	
				MOR manufacture type Esecuzione MOR Ejecución MOR	GOR manufacture type Esecuzione GOR Ejecución GOR
2	3	G	nA	IIB	IIC
22	3	D	tc	IIC	IIIB
1	2	G	D	-	IIC



## Ways to protect electric motors

Modi di protezione dei motori elettrici

Modo de protección de los motores eléctricos

	ATEX II 3G/D c T3/T125	ATEX II 2G c T3	ATEX II 2G/3G c T3	TMD ATEX II 2G c T3
Made of aluminium alloy <i>Costruzione in lega di alluminio</i> Cuerpo fabricado de aleación de aluminio	X	X	X	X
High efficiency impeller <i>Girante ad alto rendimento</i> Impulsor de alta eficiencia	X	X	X	X
Surface protection treatments <i>Trattamenti protettivi delle superfici</i> Tratamientos de superficie específicos	Option <i>Opzione</i> Opción	X	X	X
IIB group classified gas and biogas <i>Per Biogas e gas classificati gruppo IIB</i> Para biogás y gases clasificados grupo IIB		X	X	X
PN16 DN50 flange attachment complying with UNI EN 1092-1 <i>Attacco per flangia PN16 DN50 conforme UNI EN 1092-1</i> Conexión con brida PN16 DN50 conforme con UNI EN 1092-1	-	X	X	-
Sealing version <i>Versione a tenuta</i> Versión sellada	Option <i>Opzione</i> Opción	X	X	X
Enhanced sealing version <i>Versione a tenuta maggiorata</i> Versión sellada - sellado extra para mayores sollicitaciones	Option <i>Opzione</i> Opción	X	X	X
Without condensate drain <i>Senza scarico condensa</i> Sin drenaje de condensado	-	Option <i>Opzione</i> Opción	Option <i>Opzione</i> Opción	-
IP65 motors <i>Motori IP65</i> Motores con protección IP65	Option <i>Opzione</i> Opción	Option <i>Opzione</i> Opción	Option <i>Opzione</i> Opción	Option <i>Opzione</i> Opción
Special voltages (IEC 60038) <i>Tensioni Speciali (IEC 60038)</i> Voltajes especiales (IEC 60038)	Option <i>Opzione</i> Opción	Option <i>Opzione</i> Opción	Option <i>Opzione</i> Opción	Option <i>Opzione</i> Opción
ICIM certified <i>Certificato da ICIM</i> Certificado por ICIM		X	X	X

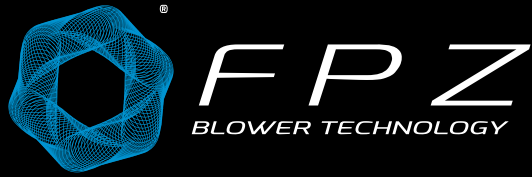

# *SIDE CHANNEL BLOWERS*

*ATEX Accessories*

*Accessori ATEX*

*Accesorios ATEX*

[fpz.com](http://fpz.com)

# ATEX



# SIDE CHANNEL BLOWERS

## Pressure gauge - *Manometro* - Manómetro con aguja

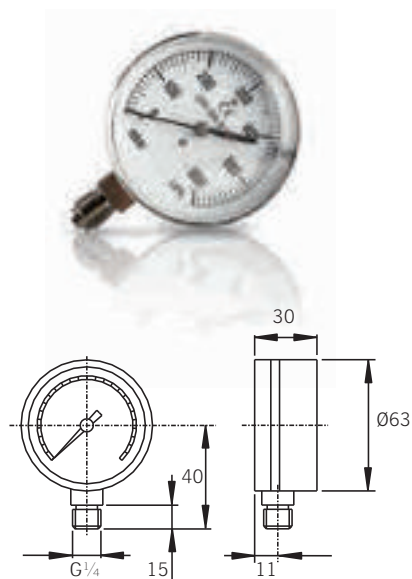

Mod	MC030	MA040
ATEX classification / <i>Classificazione ATEX</i> Clasificación ATEX	II 2 GDc T6	
Range	0 ... 1000 mbar	-1000 ... 0 mbar
Accuracy / <i>Precisione</i> / Precisión	1.6% FS	
Mechanical connection <i>Connessione meccanica</i> Conexión mecánica	G 1/4	
Protection / <i>Protezione</i> / Protección	IP 65	

Characteristics Bourdon tube pressure gauge in steel, ideal for industrial-type use

*Caratteristiche* Manometro a lancetta a tubo di Bourdon costruito in acciaio, ideale per usi di tipo industriale

Características Manómetro con aguja y tubo de Bourdon fabricado en acero, ideal para usos de tipo industrial.

## Pressure transducer - *Trasduttore di pressione* - Transductor de presión

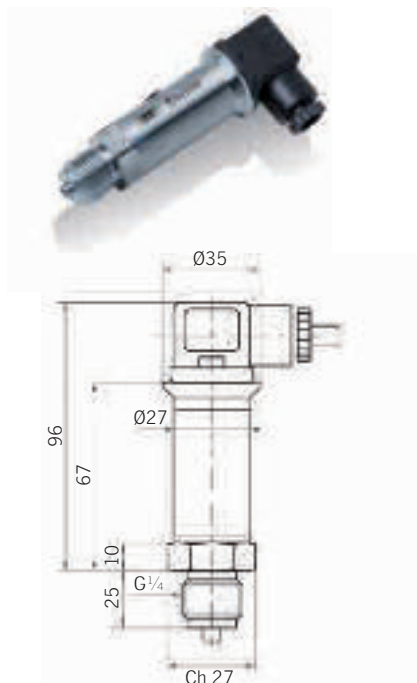

Mod	TC 420	TC 010	TA 420	TA010
ATEX classification / <i>Classificazione ATEX</i> Clasificación ATEX	II 1 GD – Ex ia IIC T5			
Range	0 ... 1000 mbar	-1000 ... 0 mbar		
Accuracy / <i>Precisione</i> / Precisión	<0.3% FS			
Mechanical connection <i>Connessione meccanica</i> Conexión mecánica	G 1/4			
Power supply / <i>Alimentazione</i> Alimentación	14-28 VDC			
Output signal / <i>Segnale in uscita</i> Señal de salida	4-20 [mA]	0-10 [V]	4-20 [mA]	0-10 [V]
Electrical connection / <i>Connessione elettrica</i> Conexión eléctrica	DIN 43650 plug			
Protection / <i>Protezione</i> / Protección	IP 65			

Characteristics Pressure transducer, accurate and reliable, suitable for use in heavy industrial environments. Allows acquisition of status and control of the system in question

*Caratteristiche* Trasduttore di pressione, preciso ed affidabile, adatto a lavorare in ambienti industriali gravosi. Permette l'acquisizione dello stato ed il controllo del sistema in esame

Características Transductor de presión, preciso y fiable, adecuado para trabajar en entornos industriales pesados. Facilita la adquisición del estado y el control del sistema examinado.

Bimetallic thermometer - *Manometro* - Termómetro bimetálico

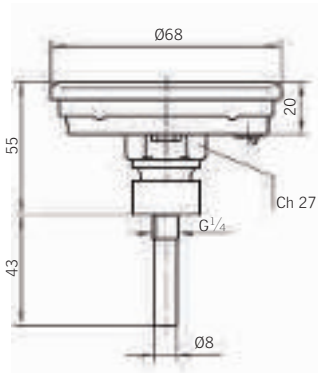

Mod	TE0160
ATEX classification / <i>Classificazione ATEX</i> Clasificación ATEX	II 2 GDc Tx
Range	20°C ... 140°C
Accuracy / <i>Precisione</i> / Precisión	1% FS
Mechanical connection <i>Connessione meccanica</i> Conexión mecánica	G 1/4
Protection / <i>Protezione</i> / Protección	IP 65

Characteristics Bimetallic thermometer for industrial use in stainless steel

*Caratteristiche* Termometro bimetallico ad uso industriale in acciaio inox

Características Termómetro bimetálico de uso industrial de acero inoxidable

Compact Pt100 thermistor - *Termoresistenza Pt100 compatto* - Termorresistencia Pt100 compacta

# SIDE CHANNEL BLOWERS

## Filter - Filtro - Filtro



### Characteristics

- Casing in cast aluminium (dimensions 230mm x 150mm)
- Filter element in washable synthetic material (viledon)
- Standard degree of filtration: 20 µm
- Filtering surface area: 10650 mm<sup>2</sup>
- Possible vertical installation
- Supplied with gaskets and screws for connection to the system
- Arranged for pressure sampling points upstream and downstream of the cartridge (G 1/4")
- EC approval according to EN 126
- In conformity with Directive 2009/142/EC (Gas Directive)
- In conformity with the 97/23/EC (PED)

### Available on request:

- degree of filtration 50 and 10 µm.
- version treated (cataphoresis) for compatibility with work fluid containing H<sub>2</sub>S

A device that stops particles of dust or debris carried by the gas, protecting the side channel blower as well as possible adjustment and safety devices. To be used with non-aggressive gases, such as manufactured gas (carbon monoxide), methane (natural gas) and LPG (liquefied petroleum gas).

È un dispositivo che impedisce il passaggio di particelle di polvere o detriti portati dal gas proteggendo la Soffiante a Canale Laterale oltre ad eventuali dispositivi di regolazione e sicurezza. È da impiegarsi con gas non aggressivi, come ad esempio gas manifatturato (ossido di carbonio), metano (gas naturale) e GPL (gas di petrolio liquefatto).

Es un dispositivo que impide el paso de partículas de polvo o residuos transportados por el gas para proteger el soplante con canal lateral y los dispositivos de regulación y seguridad. Se ha de utilizar con gases no agresivos como, por ejemplo, gas manufacturado (óxido de carbono), metano (gas natural) y GLP (gas líquido de petróleo).

### Caratteristiche

- Carcassa realizzata in alluminio pressofuso (ingombro 230mm x 150mm)
- Elemento filtrante in materiale sintetico lavabile (viledon)
- Gradi di filtraggio standard: 20 µm
- Superficie filtrante: 10650 mm<sup>2</sup>
- Installazione possibile in verticale
- Fornito con guarnizioni e viteria per il collegamento all'impianto
- Predisposizione per prese di pressione a monte e valle della cartuccia (G 1/4")
- Omologazione CE secondo EN 126
- Conforme Direttiva 2009/142/CE (Direttiva Gas)
- Conforme Direttiva 97/23/CE (Direttiva PED)

### Disponibile su richiesta

- gradi di filtrazione 50 e 10 µm.
- versione trattata (cataforesi) per compatibilità fluido di lavoro contenente H<sub>2</sub>S

### Características

- Carcasa de aluminio fundido a presión (dimensiones 230 mm x 150 mm)
- Elemento filtrante de material sintético lavable (viledon)
- Grados de filtración estándar: 20 µm
- Superficie filtrante: 10650 mm<sup>2</sup>
- Posibilidad de instalación en vertical
- Incluye juntas y tornillos de conexión al sistema
- Preinstalación con tomas de presión línea arriba y abajo del cartucho (G 1/4")
- Homologación CE según EN 126
- Conforme con la Directiva 2009/142/CE (Directiva Gas)
- Conforme con la Directiva 97/23/CE (Directiva PED)

### Disponibile bajo pedido

- grados de filtración 50 y 10 µm
- versión tratada (cataforesi) para compatibilidad con fluido de trabajo con H<sub>2</sub>S

FILTRO	Mod	Flanged connect Attacchi flangiati Connexion bridas	Degree of Filtration Grado di Filtrazione Grado Filtración [µm]	Weight Peso [kg]
	FF40J10	DN 40		10
FF40J20	20			
FF40J50	50			
FF50J10	DN 50		10	2,70
FF50J20			20	
FF50J50			50	

CARTUCCIA	Mod	Filter Filtro Filtro	Dimensions Dimensioni Dimensiones	Weight Peso [g]
	25CF10M		FF40J10	140 x 105 x 35
FF50J10				
25CF20M		FF40J20		
		FF50J20		
25CF50M		FF40J50		
		FF50J50		

## Antivibration joints - Giunti antivibranti - Juntas antivibración



### Characteristics

- In AISI 316L stainless steel
- Anti-twisting grooving to avoid problems during assembly
- Supplied with gaskets and screws for connection to the system

### Caratteristiche

- Realizzato in acciaio inox AISI 316L
- Scanalatura anti-torsione per evitare problemi durante il montaggio
- Fornito con guarnizioni e viteria per il collegamento all'impianto

### Características

- Realizado en acero inoxidable AISI 316L
- Ranura antitorsión para evitar problemas durante el montaje
- Incluye juntas y tornillos de conexión al sistema

A device allowing the machine to be uncoupled from the system, preventing the transmission of vibration and allowing the adjustment of any misalignments.

È un dispositivo che consente di disaccoppiare la macchina dall'impianto, prevenendo la trasmissione di vibrazioni e consentendo di recuperare eventuali disallineamenti.

Es un dispositivo que permite desacoplar la máquina del sistema evitando la transmisión de vibraciones y permitiendo corregir la eventual desalineación.

**FPZ**  
Via F.lli Cervi 16  
29043 Concorezzo (MB)  
Tel. +39 039 60 41 296  
Fax +39 039 60 41 296  
info@fpz.com - www.fpz.com

**EU DECLARATION OF CONFORMITY**

The manufacturer:  
**FPZ S.p.A.** located in Via F.lli Cervi n. 16, Concorezzo (MB) Italy

DECLARES ON HIS SOLE RESPONSIBILITY THAT THE FOLLOWING PRODUCTS

SIDE CHANNEL BLOWERS:

**K07-MS GOR TMD  
K08-MS GOR TMD**

**K09-MS GOR TMD  
K10-MS GOR TMD**

**K11-MS GOR TMD**

MARKED

**II 2G - Ex h IIB T3 Gb**

Admissible room and intake temperature from -15 °C to +40 °C

**Satisfy the requirements of ATEX 2014/34/EU Directive that apply to them**

Harmonized standards used for assessment of conformity:  
EN 1127-1  
EN 80079-36  
EN 80079-37  
EN 14986  
EN 60079-14

Technical standard used for assessment of conformity:  
The manufacturer declares that the procedure followed for assessing the conformity of the equipment is "Module A, Internal production control", Annex VIII of the directive.  
Number of receipt of the technical documentation: TUV IT 18 ATEX 044 AR  
Notified Body number: 0948

The buyer and the user are responsible for the correct choice and use of the product, according to the current laws relating to equipment for use in potentially explosive atmospheres.

**Moreover, comply with all the relevant provisions of Machinery Directive 2006/42/EC**

Concorezzo  
29 October 2018  
The Authorized Technician  
Andrea Lazari

**FPZ**  
Via F.lli Cervi 16  
29043 Concorezzo (MB)  
Tel. +39 039 60 41 296  
Fax +39 039 60 41 296  
info@fpz.com - www.fpz.com

**EU DECLARATION OF CONFORMITY**

The manufacturer:  
**FPZ S.p.A.** located in Via F.lli Cervi n. 16, Concorezzo (MB) Italy

DECLARES ON HIS SOLE RESPONSIBILITY THAT THE FOLLOWING PRODUCTS

SIDE CHANNEL BLOWERS:

**Series R20-R30-R40 MD GOR**

MARKED

**II 2G - Ex h IIC T3 Gb  
II 2G - Ex h IIC T4 Gb  
II 2G/3G - Ex h IIC T3 Gb/Gc  
II 2G/3G - Ex h IIC T4 Gb/Gc**

Admissible room and intake temperature from -15 °C to +40 °C

**Satisfy the requirements of ATEX 2014/34/EU Directive that apply to them**

Harmonized standards used for assessment of conformity:  
EN 1127-1  
EN 80079-36  
EN 80079-37  
EN 14986  
EN 60079-14

Technical standard used for assessment of conformity:  
The manufacturer declares that the procedure followed for assessing the conformity of the equipment is "Module A, Internal production control", Annex VIII of the directive.  
Number of receipt of the technical documentation: TUV IT 18 ATEX 045 AR  
Notified Body number: 0948

The buyer and the user are responsible for the correct choice and use of the product, according to the current laws relating to equipment for use in potentially explosive atmospheres.

**Moreover, comply with all the relevant provisions of Machinery Directive 2006/42/EC**

Concorezzo  
13 September 2018  
The Authorized Technician  
Andrea Lazari

**FPZ**  
Via F.lli Cervi 16  
29043 Concorezzo (MB)  
Tel. +39 039 60 41 296  
Fax +39 039 60 41 296  
info@fpz.com - www.fpz.com

**EU DECLARATION OF CONFORMITY**

The manufacturer:  
**FPZ S.p.A.** located in Via F.lli Cervi n. 16, Concorezzo (MB) Italy

DECLARES ON HIS SOLE RESPONSIBILITY THAT THE FOLLOWING PRODUCTS

SIDE CHANNEL BLOWERS:

**K05-MS MOR  
K06-MS MOR**

MARKED

**II 2G - Ex h IIB T3 Gb  
II 2G/3G - Ex h IIC T3 Gb/Gc**

Admissible room and intake temperature from -15 °C to +40 °C

**Satisfy the requirements of ATEX 2014/34/EU Directive that apply to them**

Harmonized standards used for assessment of conformity:  
EN 1127-1  
EN 80079-36  
EN 80079-37  
EN 14986  
EN 60079-14

Technical standard used for assessment of conformity:  
The manufacturer declares that the procedure followed for assessing the conformity of the equipment is "Module A, Internal production control", Annex VIII of the directive.  
Number of receipt of the technical documentation: TUV IT 18 ATEX 046 AR  
Notified Body number: 0948

The buyer and the user are responsible for the correct choice and use of the product, according to the current laws relating to equipment for use in potentially explosive atmospheres.

**Moreover, comply with all the relevant provisions of Machinery Directive 2006/42/EC**

Concorezzo  
29 October 2018  
The Authorized Technician  
Andrea Lazari

**FPZ**  
Via F.lli Cervi 16  
29043 Concorezzo (MB)  
Tel. +39 039 60 41 296  
Fax +39 039 60 41 296  
info@fpz.com - www.fpz.com

**EU DECLARATION OF CONFORMITY**

The manufacturer:  
**FPZ S.p.A.** located in Via F.lli Cervi n. 16, Concorezzo (MB) Italy

DECLARES ON HIS SOLE RESPONSIBILITY THAT THE FOLLOWING PRODUCTS

SIDE CHANNEL BLOWERS:

**Series R20-R30-R40 MD GOR**

MARKED

**II 2G - Ex h IIC T3 Gb  
II 2G - Ex h IIC T4 Gb  
II 2G/3G - Ex h IIC T3 Gb/Gc  
II 2G/3G - Ex h IIC T4 Gb/Gc**

Admissible room and intake temperature from -15 °C to +40 °C

**Satisfy the requirements of ATEX 2014/34/EU Directive that apply to them**

Harmonized standards used for assessment of conformity:  
EN 1127-1  
EN 80079-36  
EN 80079-37  
EN 14986  
EN 60079-14

Technical standard used for assessment of conformity:  
The manufacturer declares that the procedure followed for assessing the conformity of the equipment is "Module A, Internal production control", Annex VIII of the directive.  
Number of receipt of the technical documentation: TUV IT 18 ATEX 045 AR  
Notified Body number: 0948

The buyer and the user are responsible for the correct choice and use of the product, according to the current laws relating to equipment for use in potentially explosive atmospheres.

**Moreover, comply with all the relevant provisions of Machinery Directive 2006/42/EC**

Concorezzo  
13 September 2018  
The Authorized Technician  
Andrea Lazari

**ERC**  
EUROPEAN REGISTERED CERTIFICATE

CONFORMITY WITH THE REQUIREMENTS OF THE DIRECTIVE 2006/42/EC OF THE EUROPEAN PARLIAM AND OF THE COUNCIL OF 6 JULY 2006 ON THE APPROXIMATION OF THE LAWS, REGULATIONS, ADMINISTRATIVE PROVISIONS AND STANDARDS RELATING TO MACHINERY

Product description: SIDE CHANNEL BLOWERS

Manufacturer: FPZ S.p.A. - Via F.lli Cervi 16 - 29043 Concorezzo (MB) - Italy

Model: K07-MS GOR TMD, K08-MS GOR TMD, K09-MS GOR TMD, K10-MS GOR TMD, K11-MS GOR TMD

Notified Body: TÜV SÜD

Notified Body Number: 0948

Issue Date: 29 October 2018

Valid Until: 29 October 2021

Signature: Andrea Lazari

**DNV-GL**

**MANAGEMENT SYSTEM CERTIFICATE**

FPZ S.p.A.

Via F.lli Cervi 16 - 29043 Concorezzo (MB) - Italy

ISO 9001:2015 (ISO 9001:2015)

Notified Body: DNV-GL

Notified Body Number: 0948

Issue Date: 13 September 2018

Valid Until: 13 September 2021

Signature: Andrea Lazari

# SIDE CHANNEL BLOWERS

## FPZ UK Ltd.

Andover Hampshire, UK  
T +44 1264 889 001  
[uk@fpz.com](mailto:uk@fpz.com)

## FPZ, Inc.

Saukville, Wisconsin, USA  
T +1 262 268 0180  
[usa@fpz.com](mailto:usa@fpz.com)

## FPZ España & Portugal

Barcelona, Spain  
T +34 607 62 32 03  
[iberica@fpz.com](mailto:iberica@fpz.com)

## FPZ México

Zapopan, Jalisco, México  
T +52 333 634 3215  
[mexico@fpz.com](mailto:mexico@fpz.com)



**Headquarters**  
**FPZ S.p.A.**  
Concorezzo, Italy  
T +39 039 69 09 81  
[info@fpz.com](mailto:info@fpz.com)



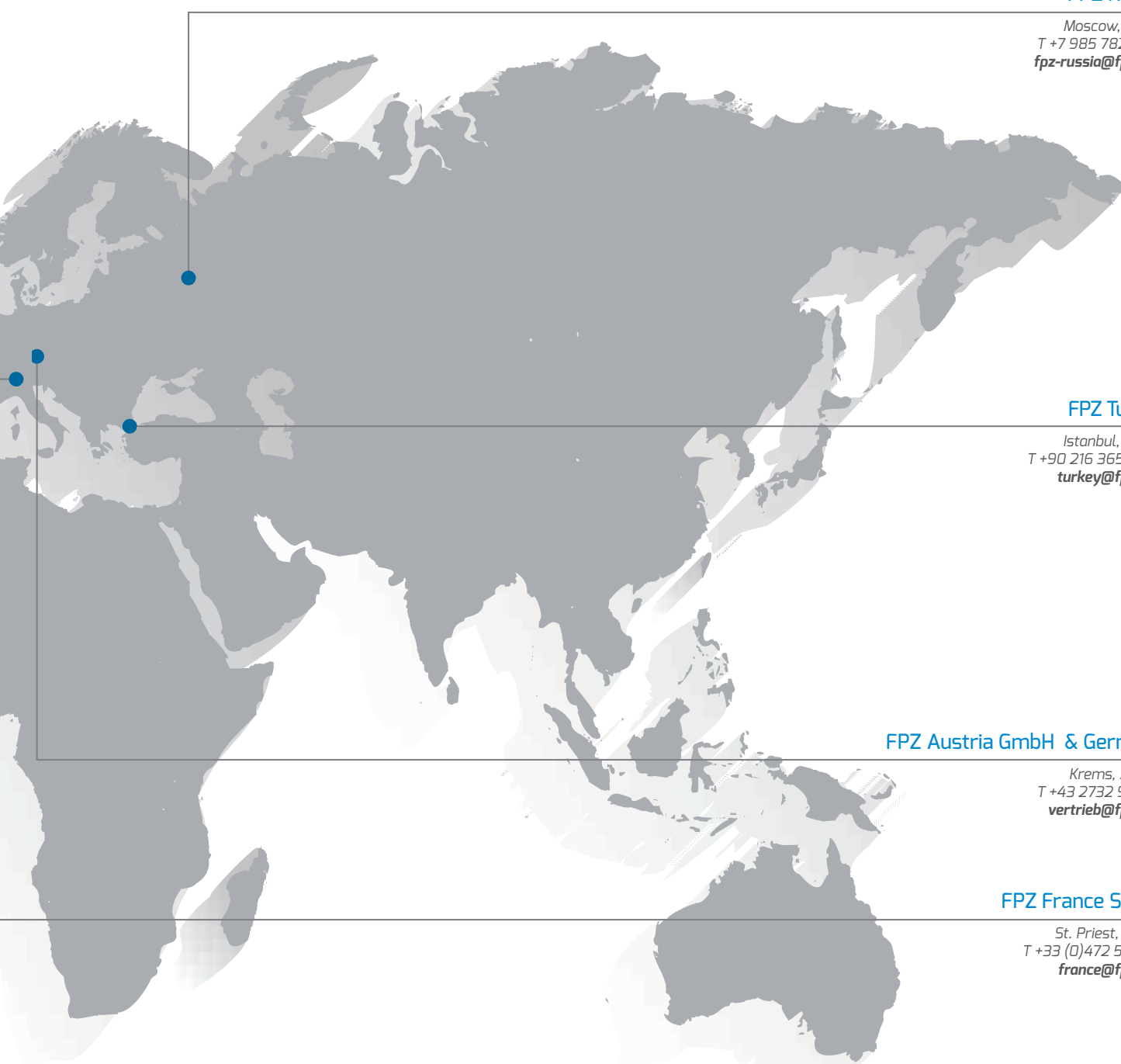

**FPZ Russia**

Moscow, Russia  
T +7 985 782 08 81  
fpz-russia@fpz.com

**FPZ Turkey**

Istanbul, Turkey  
T +90 216 365 65 26  
turkey@fpz.com

**FPZ Austria GmbH & Germany**

Krems, Austria  
T +43 2732 908 80  
vertrieb@fpz.com

**FPZ France S.a.r.l.**

St. Priest, France  
T +33 (0)472 50 13 13  
france@fpz.com

COMPANY WITH  
QUALITY SYSTEM  
CERTIFIED BY DNV GL  
ISO 9001



Pressure - *Pressione* - Presión

Beginning Units <i>Unità di partenza</i> Unidades iniciales	Conversion factor <i>Fattore di conversione</i> Factor de conversión	Resulting units <i>Unità risultanti</i> Unidades resultantes
Pa	0,01	mbar
hPa	1,0	mbar
kPa	10,0	mbar
mm H <sub>2</sub> O	0,098	mbar
m H <sub>2</sub> O	98,07	mbar
at	980,7	mbar
inch H <sub>2</sub> O	2,491	mbar
PSI lpf/in <sup>2</sup>	68,948	mbar
mbar	100	Pa
mbar	10,2	mm H <sub>2</sub> O
mbar	10,2 x 10 <sup>-3</sup>	m H <sub>2</sub> O
mbar	10,2 x 10 <sup>-3</sup>	at
mbar	0,4016	inch H <sub>2</sub> O
mbar	14,505 x 10 <sup>-3</sup>	PSI lpf/in <sup>2</sup>

Suction flow - *Capacità di aspirazione* - Capacidad de aspiración

Beginning Units <i>Unità di partenza</i> Unidades iniciales	Conversion factor <i>Fattore di conversione</i> Factor de conversión	Resulting units <i>Unità risultanti</i> Unidades resultantes
l/min	0,06	m <sup>3</sup> /h
gal/min	0,227	m <sup>3</sup> /h
ft <sup>3</sup> /min	1,699	m <sup>3</sup> /h
m <sup>3</sup> /h	16,667	l/min
m <sup>3</sup> /h	4,403	gal/min
m <sup>3</sup> /h	0,588	ft <sup>3</sup> /min

Power - *Potenza* - Potencia

Beginning Units <i>Unità di partenza</i> Unidades iniciales	Conversion factor <i>Fattore di conversione</i> Factor de conversión	Resulting units <i>Unità risultanti</i> Unidades resultantes
HP	0,746	kW
Btu/h	293,1	kW
kW	1,341	HP
kW	3,41 x 10 <sup>-3</sup>	Btu/h

Length - *Lunghezza* - Longitud

Beginning Units <i>Unità di partenza</i> Unidades iniciales	Conversion factor <i>Fattore di conversione</i> Factor de conversión	Resulting units <i>Unità risultanti</i> Unidades resultantes
in.	25,4	mm
in.	0,0254	m
ft	305	mm
ft	0,305	m
m	39,37	in.
m	3,28	ft

Temperature conversion - *Conversione della temperatura* - Conversión de temperatura

From <i>Da</i> De	To <i>A</i> A	
°F	K	$T[K] = \frac{t[°F] + 459,67}{1,8}$
°F	°C	$t[°C] = \frac{t[°F] - 32}{1,8}$
K	°F	$t[°F] = 1,8 \times T[K] - 459,67$
°C	°F	$t[°F] = 1,8 \times t[°C] + 32$

Mass - *Massa* - Masa

Beginning Units <i>Unità di partenza</i> Unidades iniciales	Conversion factor <i>Fattore di conversione</i> Factor de conversión	Resulting units <i>Unità risultanti</i> Unidades resultantes
lbm	0,454	kg
kg	2,205	lbm

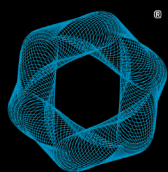

**FPZ**  
BLOWER TECHNOLOGY

[fpz.com](http://fpz.com)

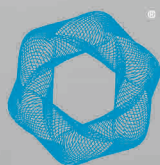

**FPZ**  
BLOWER TECHNOLOGY

visit us:

