

USE CASE

Operation examples

Electronic Parts Inspection

Operate the AX with multiple machines and achieve high tact

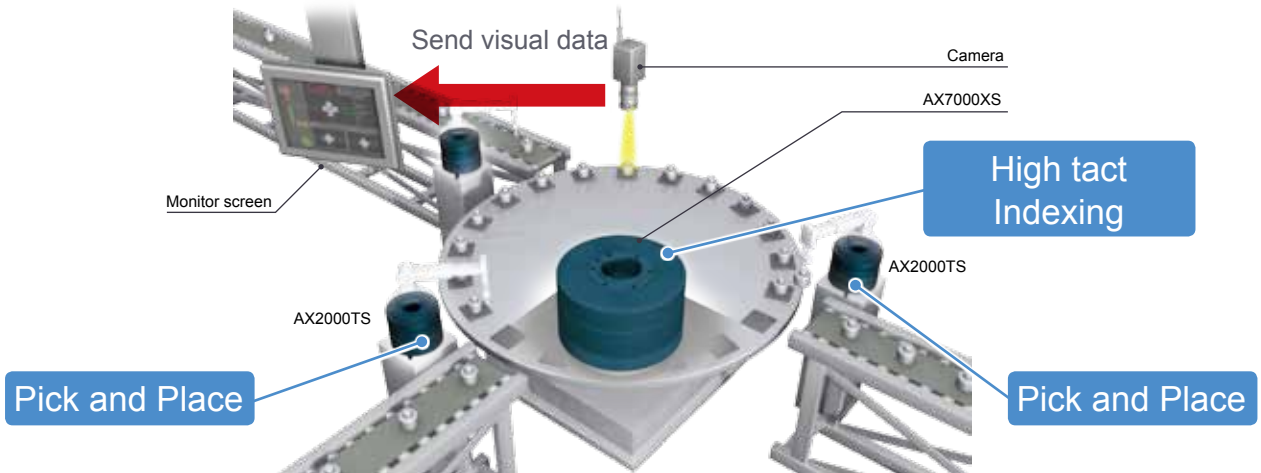

Laser Labeling of Workpieces

Laser marking is done at constant increments.

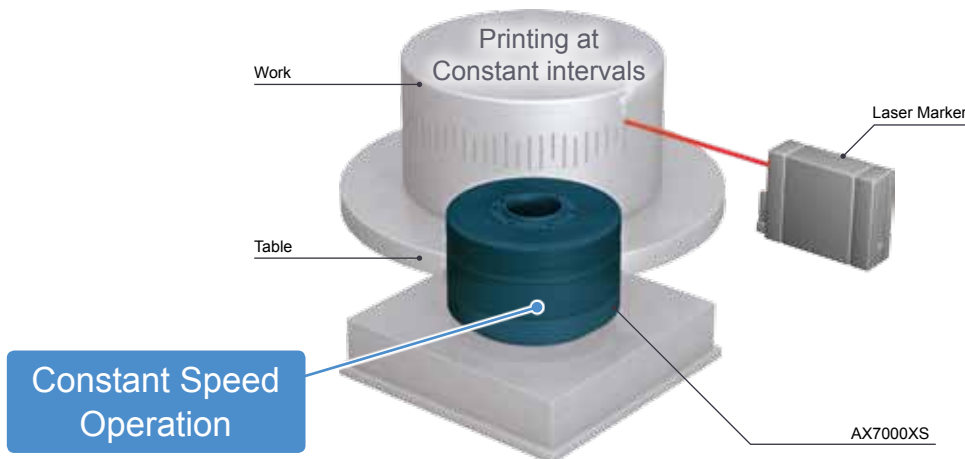

Laser Labeling of Workpieces

Laser marking is done at constant increments.

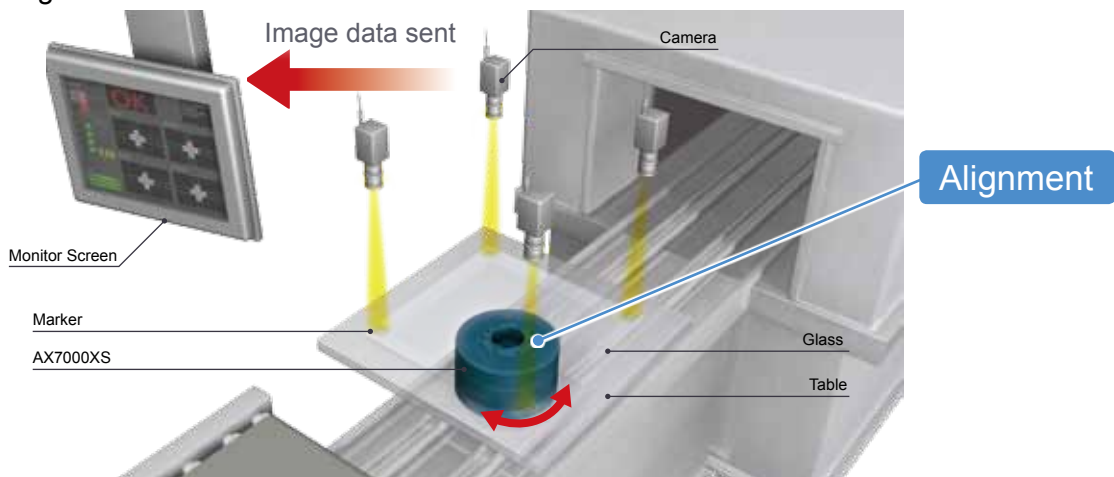

USE CASE

Conveyor of Electronic Substrate

Rotate electronic substrates by 90°

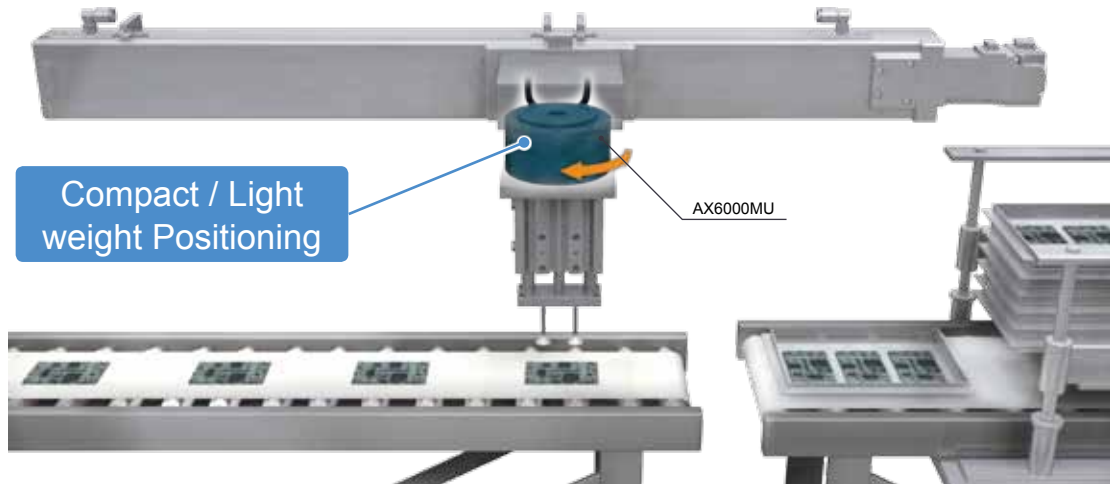

Pick and Place

Work is conveyed using an equipped parallel displacement mechanism.

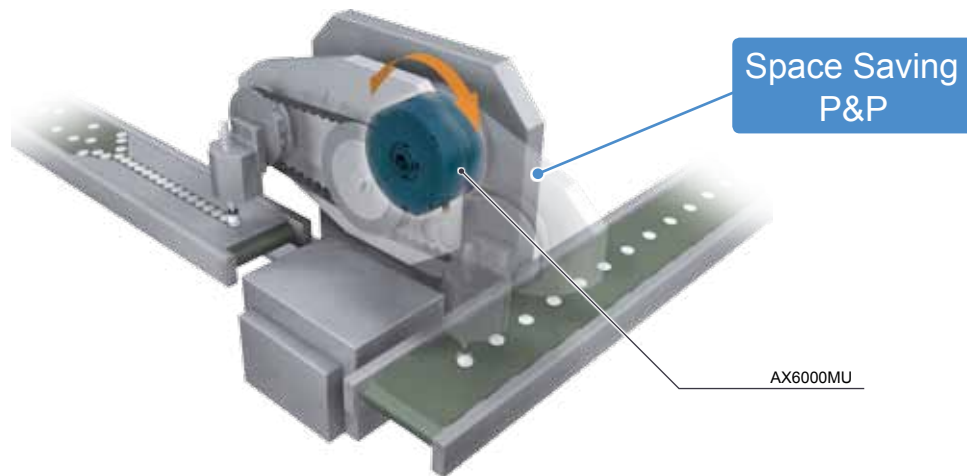

Assembly, Inspection Machines

Conduct setup changes without time loss

