

Linear Units



Helping you build a better machine, faster.

Product Overview

Danaher Motions linear units are divided in to seven different categories to make the selection process of an unit easier.

Ball screw driven - ball guided units

Units designed for high thrust, payload, precision and stiffness.

- Force up to 12000 N
- Repeatability down to 0,005mm

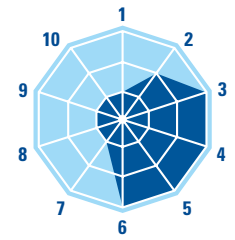

Ball screw driven - slide guided units

Low cost units for high thrust applications and demanding environments.

- Durable guide system
- Washdown protected version

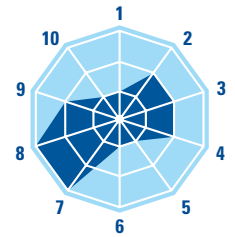

Belt driven - ball guided units

Smooth running units for high speed, acceleration and load requiring a long lifetime.

- Speed up to 5 m/s
- Acceleration up to 40 m/s²

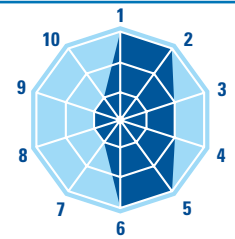

Belt driven - slide guided units

Units for applications requiring smooth travel, high speed, high acceleration and low maintenance.

- Cost efficient guide system
- Chemically protected versions

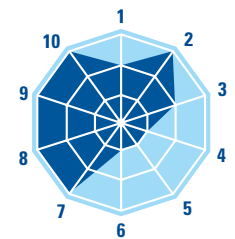

Belt driven - wheel guided units

Units for high speed, high acceleration, smooth motion and medium to high loads.

- Speed up to 10 m/s
- Acceleration up to 40 m/s²

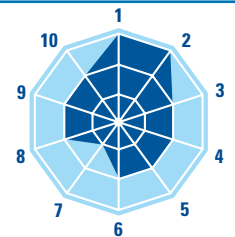

Linear lifting units

Units for lifting applications that often are used in X-Y configurations in combination with other linear units.

Linear rod units

Units designed for lifting applications or for the replacement of hydraulic and pneumatic cylinders.

1. Velocity
2. Acceleration
3. Repeatability
4. Force
5. Load torque
6. Stiffness
7. Guide robustness
8. Cost
9. Maintenance
10. Noise

The History of Linear Units is the History of Us

Danaher Motions linear unit range consists of products from the world known brands Thomson, Neff and Tollo. These three companies have been in the front of the linear unit development for decades and are now forming one group of products under the Danaher Motion name. Regardless of your application you can be sure that Danaher Motion can offer you a product to match your linear motion needs.

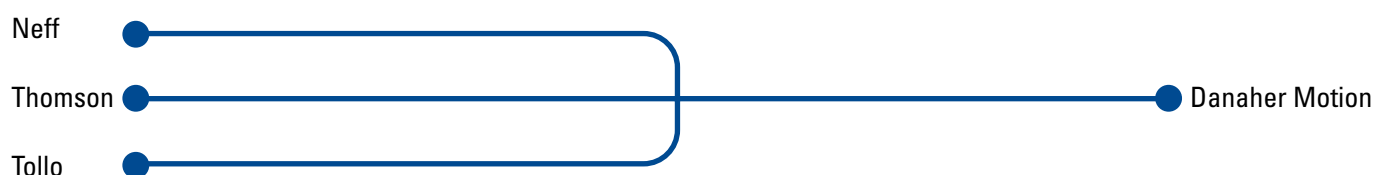



Neff was founded in 1905 offering products for the linear motion market and over the decades Neff has become a market leader in the ball screw technology. The first linear unit from Neff was presented in 1981 at the FAMETA show in Stuttgart. Thomson dates back to the 1940s when the first ball bushing bearing in the world was presented to the market. The product portfolio expanded and in the 1980s Thomson built their first complete linear unit. Tollo was founded in 1981 and started as a lifting equipment manufacturer, the product portfolio grew rapidly and in 1982 Tollo presented their first linear unit at the Technical Fair in Stockholm.

Danaher Motion has now selected the most competitive products from each brand resulting in a state of the art product range. The range covers the smallest and most compact linear units to the biggest and most robust. With a wide range of guide systems that have the ability to work in harsh environments, at high speeds or in high precision systems in combination with the best ball screw and belt drive technologies available ensure that Danaher Motion can match your linear motion needs.



Performance Overview

		Ball Screw, Ball Guides	Ball Screw, Slide Guides	Belt Drive, Ball Guides	
					
Profile Size					
Smallest unit	[mm]	40 × 40	40 × 37	40 × 40	
Largest Unit	[mm]	240 × 85	108 × 100	240 × 85	
Stroke Length					
Maximum stroke length	[mm]	11000	6000	12000	
Speed					
Maximum speed	[m/s]	2,5	1,6	5	
Maximum acceleration	[m/s ²]	20	8	40	
Accuracy					
Maximum repeatability	[±mm]	0,005	0,05	0,05	
Load					
Maximum load, Fx	[N]	12000	5000	5000	
Maximum load, Fy	[N]	38000	3005	6400	
Maximum load, Fz	[N]	38000	3005	6400	
Maximum load torque, Mx	[Nm]	2760	117	600	
Maximum load torque, My	[Nm]	2130	279	720	
Maximum load torque, Mz	[Nm]	2130	279	720	
Features					
Units with double carriages		•	•	•	
Units with left/right carriages		•	•		
Telescoping units					
Non driven units		•	•	•	
Units with cover band		•	•	•	
Wash down protected units		•	•	•	
Chemically protected units					
Accessories					
Mounting kits		•	•	•	
Gear boxes		•	•	•	
Servo motors		•	•	•	
Limit switch / sensor brackets		•/•	•/•	•/•	
Feedback devices / brackets		•/•	/•	•/•	

	Belt Drive, Slide Guides	Belt Drive, Wheel Guides	Linear Lifting Units	Linear Rod Units
				
	50 × 50 108 × 100	50 × 50 240 × 85	50 × 50 188 × 150	60 × 60 130 × 130
	12000	11000	3000	2000
	5 40	10 40	10 40	2 20
	0,2	0,05	0,05	0,05
	1250 3005 3005 117 279 279	5000 5000 9300 500 930 500	1480 882 7500 2000 2000 330	40000 2000 2000 50 300 300
	•	•	•	
			•	•
	•	•		
	•	•		
	•	•	•	•
	•			•
	•	•	•	•
	•	•	•	•
	•	•	•	•
	•/•	•/•	•/•	/•
	/•	•/•	•/•	

Danaher Motion Linear Unit Features

Danaher Motion linear units are available in the five main categories offering you as a customer an unmatched product range to select from. With almost 50 models available plus a broad range of accessories this makes Danaher Motion the only linear unit partner you need.

Drive and guide technology advantages:

- screw driven units with ball guides for high loads and high precision
- screw driven units with prism guides for medium to high load and durable guide system
- belt driven units with ball guides for high load and dynamics
- belt driven units with wheel guides for applications requiring extreme speed and acceleration
- belt driven units with prism guide for low cost and durable guide system.

Screw or belt drive

Danaher Motion linear units can be driven by either a screw system or a tooth belt system. We use a broad variety of screw and belt types to meet the specification for all possible applications.

A screw driven (A) system is normally recognised by high thrust and stiffness and can be based on a low cost lead screw with preloaded nut, through to a standard commercial rolled ball screw or even a state of the art high precision ground ball screw.

A belt driven system (B) is chosen when acceleration and speed are the most important criteria. Our belt driven units use a wide range of different belts from leading belt manufacturers.

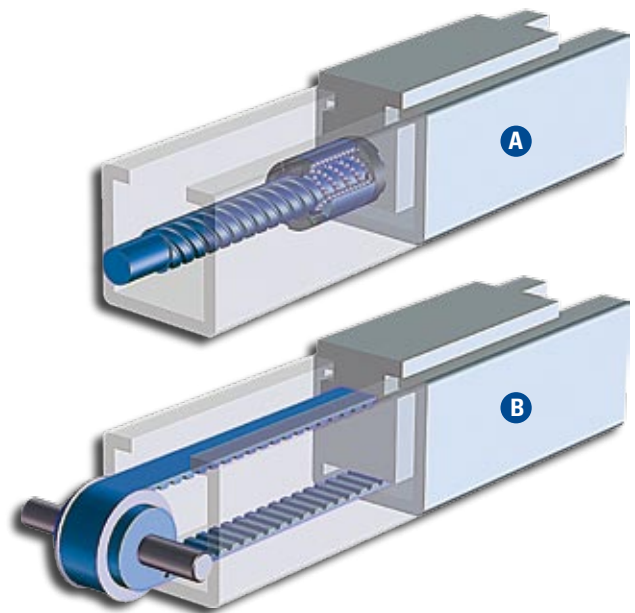

Fast wheel guides

A wheel guided system offers a perfect combination of stiffness and dynamics. With high load capacity and unmatched speed and acceleration, wheel guides is the perfect choice for a dynamic application. Years of experience ensure that you get the best in class technology when choosing a Danaher Motion wheel guided linear unit.

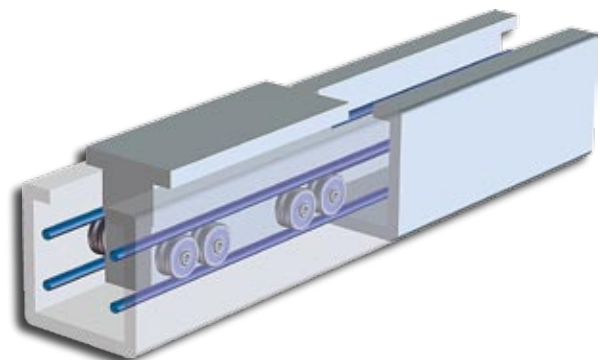

Danaher Motion Linear Unit Features

Danaher Motion offer more than 25 different ball guided models to choose from. Regardless the type of application we have the product to meet your demands. For handling and packaging the best choice normally is the wheel guided or prism guided units offering outstanding performance and cost performance ratio. Wheel guided units offering outstanding performance and cost performance ratio. Wheel guided systems are recognised for high load, acceleration and speed while prism guided units are known for their robustness and durability. Prism guided units are also available in washdown and chemically protected versions withstanding the harsh environments in food factories, paper mills and in chemical plants.

High precision ball guides

Danaher Motion ball guided linear units come in two different versions.

The first version (C) has a unique ball guide developed by Danaher Motion. This integrated ball guide system is used in some of the ball guided units and offers outstanding load carrying performance along with high accuracy and a long life expectancy.

The second version (D) are based on a commercial type of ball guide which offers smooth and quiet travel and the highest precision. These ball guided systems offer the best performance on the ball guide market today.

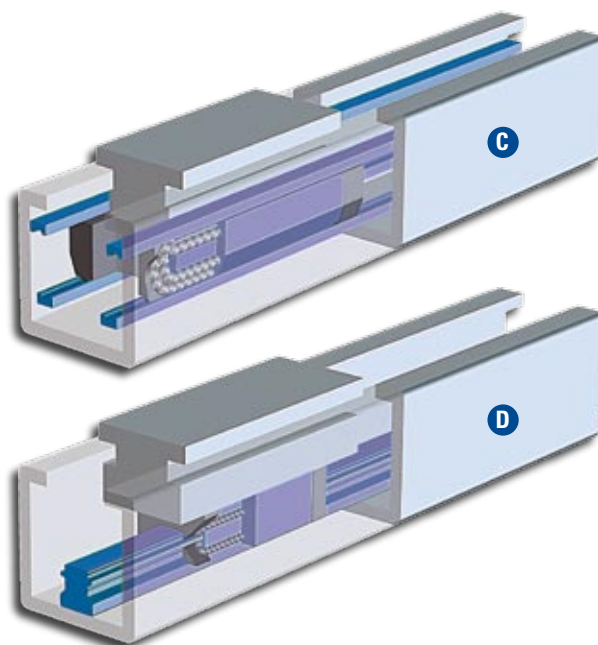

Robust prism guides

The unique self aligning prism guide system uses prism shaped polymer bushings running directly on the anodised profile surface. The prism guides offers a cost efficient, smooth, reliable and maintenance free guiding system. Resistant to shock loads, dust and dirt it is the best choice for applications in demanding environments.

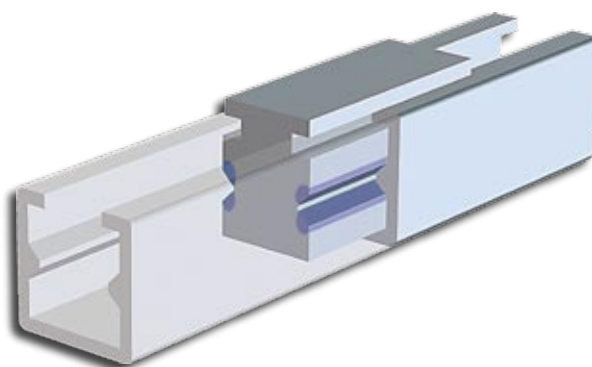

Danaher Motion Linear Unit Features

The Danaher Motion linear unit products range from very small units to the largest ones available. Profile sizes range from as small as 25 mm up to 130 mm in height and up to almost 240 mm in width. We can offer linear units with stroke lengths from only a few hundred millimeters up to as much as 12 meters as standard.

Linear unit features:

- all units based on anodised corrosion resistant aluminium profiles
- units with left and right moving carriages available
- play free screw driven units available
- linear units with single or double carriages available

Patented screw support technology

All screw driven units can be delivered with screw supports to ensure high speed at long strokes. Some screw supported units has a unique patented screw support system which offers you full speed up to strokes of 11 meters and adds on less length to the unit than other screw support systems on the market due to its outstanding stroke to total length of the unit ratio.

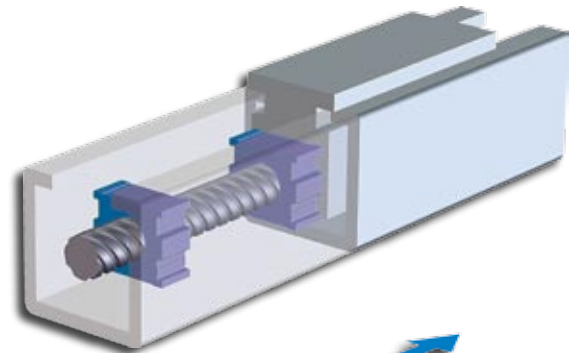

Long stroke lengths

With strokes lengths up to 12 meters for belt driven units and up to 11 meters for screw driven units Danaher Motion offer the longest stroke lengths on the market.

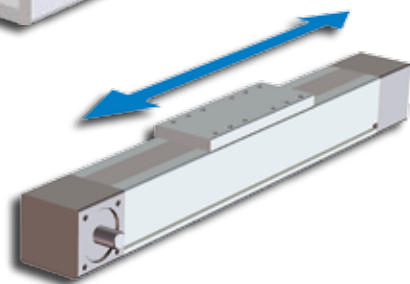

Unique cover band technologies

Sealing the units from water, dust and other contamination is essential for a long and trouble free life. Danaher Motion can offer two best in class sealing technologies. Either a stainless cover band (E) kept in place with magnet strips or a plastic cover band (F) that is self-locking to the aluminium profile. Another unique feature is the cover band stretching function eliminating any cover band slack thus increasing the life of the cover band.

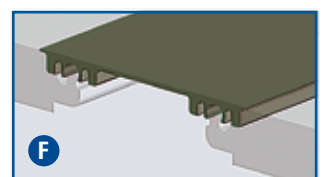
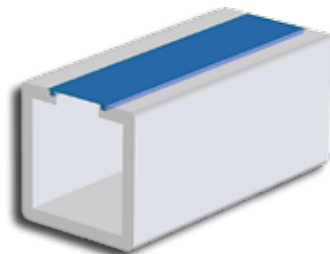

Danaher Motion Linear Unit Features

Danaher Motion offers an unmatched selection of accessories such as gearboxes, sensors, feedback devices and fixation parts to allow easy mounting of the linear units to any machine or application. We also offer predefined motor and drive packages as well as accessories for multi axis applications making it possible to create complete automation, handling and robotic systems.

- modern design means fast and easy installation
- little or no maintenance required
- high quality and modern production ensures long and reliable life.

Central lubrication

For demanding applications in high performance machinery easy and fast maintenance is a must. By choosing a unit with central lubrication the lubrication is applied at one point ensuring that guides as well as the drive screw is lubricated and kept intact throughout the lifetime of the unit.

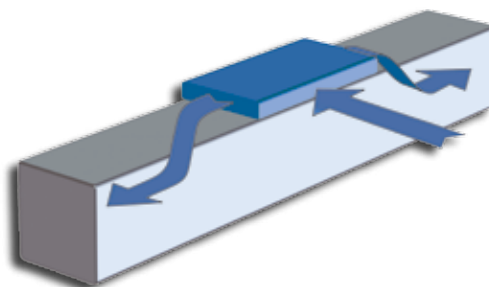

Stainless units

There are two types of stainless units, washdown or chemically protected. Washdown protected units are screw or belt driven prism guided units upgraded so that they can operate in wet and humid environments such as food, dairy and slaughter plants. Chemically protected units are belt driven prism guided units that are further upgraded to tolerate basic and acid liquids making them suitable for paper mills, galvanising plants and the chemical industry in general.

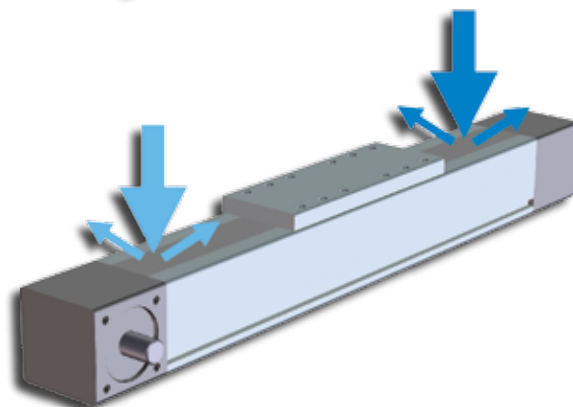

Packages and multi axis solutions

By combining the unique linear units from Danaher Motion and utilizing the predefined mounting components it is easy to create multi axis systems. Combining this with our range of servo motors, servo drives and motion controllers ensures a state of the art motion system.

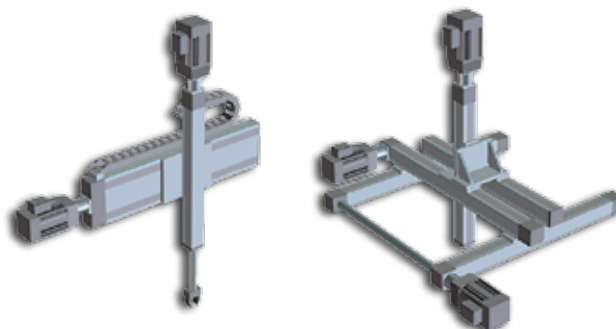

Applications

Linear units are the solution in many types of manual and automatic equipments. The large range of models and sizes makes it easy to find the perfect linear unit for your needs.

Advantages:

- state of the art technology
- easy to use sizing & selection software
- free to use 3D CAD blocks available
- world wide sales, support and service
- large network of system houses and integrators
- one of the largest linear unit suppliers in the world

General automation



Combining Danaher Motion linear products enables you to solve any automation application. Our products are well known among Europe's car manufacturers and system houses.

Machining



By selecting our high performance screw driven and ball guided products most of the machining movements can be made easier and more cost efficient. Combining with servomotors, gearboxes and drives we are able to offer you the complete motion solution.

Assembly

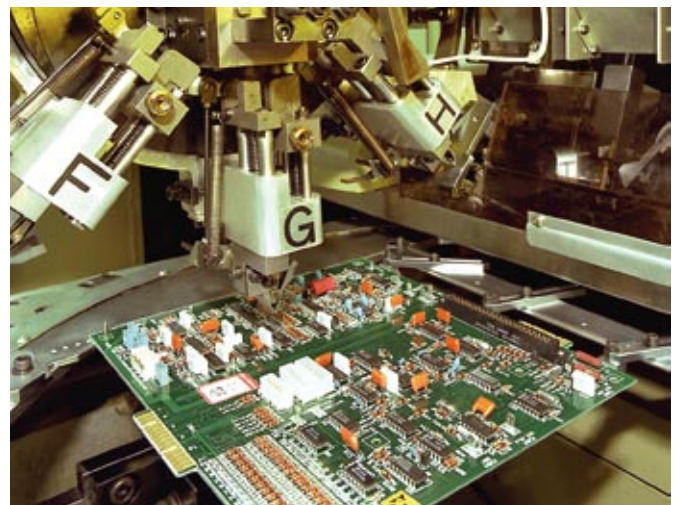

High precision screw system and ball guide system enables you to solve high precision pick and place applications as well as soldering and inspection tasks.

Applications

Danaher Motion has over 100 years of linear motion experience and our application engineers are never further away than a phone call. Contact us today to learn more about how we can help you making linear motion easy.

- large range of accessories
- multi axis kits
- customised units
- ISO 9001 certified production
- short delivery times.

Packaging and palletizing



Our wheel guided and prism guided linear units are directly developed to suit the needs for the packaging, printing and scanning industry. The food, beverage and paper industries are since long our customers.

Robotics



Danaher Motion's wide range of linear and lifting units, gear boxes, motors and drives, enables you to create many different types of robotic systems for advanced applications.

Materials handling



Combining Danaher Motion overhead rail products with the linear lifting units enables you to solve any material handling application. We offer predefined lifting units but you can combine any of our products to suit your needs.

EUROPE

United Kingdom

Danaher Motion
Chartmoor Road, Chartwell Business Park
Leighton Buzzard, Bedfordshire
LU7 4WG; United Kingdom
Phone: +44 (0)1525 243 243
Fax: +44 (0)1525 243 244
E-mail: sales.uk@danahermotion.com

Germany

Danaher Motion GmbH
Sales Office North
Wacholderstr. 40-42
40489 Düsseldorf
Germany
Phone: +49 (0) 203 9979 214
Fax: +49 (0) 203 9979 3214
E-Mail: iris.tolusch@danahermotion.com

Danaher Motion GmbH
Sales Office South West
Brückenfeldstraße 26/1
75015 Bretten
Germany
Phone: +49 (0) 7252 97390 56
Fax: +49 (0) 7252 97390 55
E-Mail: kerstin.mueller@danahermotion.com

Danaher Motion GmbH
Sales Office South East
Kiesgräble 7
89129 Langenau
Germany
Phone: +49 (0) 7471 62 23 23
Fax: +49 (0) 7471 62 23 26
E-Mail: ursula.koschak@danahermotion.com

France

Danaher Motion
C.P 80018
12, Rue Antoine Becquerel – Z.I. Sud
F-72026 Le Mans Cedex 2
France
Phone: +33 (0) 243 50 03 30
Fax: +33 (0) 243 50 03 39
E-mail: sales.france@tollo.com

Italy

Danaher Motion srl
Largo Brughetti
I-20030 Bovisio Masciago
Italy
Phone: +39 0362 594260
Fax: +39 0362 594263
E-mail: info@danahermotion.it

Sweden

Danaher Motion
Box 9053
SE-291 09 Kristianstad
Sweden
Phone: +46 (0) 44-24 67 00
Fax: +46 (0) 44-24 40 85
E-mail: helpdesk.kid@danahermotion.com

Switzerland

Danaher Motion SA
La Pierreire 2
1029 Villars-Ste-Croix
Switzerland
Phone: +41 (0) 21 631 33 33
Fax: +41 (0) 21 636 05 09
E-mail: info@danaher-motion.ch

USA, CANADA and MEXICO

Danaher Motion
203A West Rock Road
Radford, VA 24141 USA
Phone: 1-540-633-3400
Fax: 1-540-639-4162
E-mail: DMAC@danahermotion.com
Literature: LitRequest@danahermotion.com

ASIA

China

Danaher Motion
Rm 2205, Scitech Tower
22 Jianguomen Wai Street
Beijing, China, 100004
Phone: +86 10 6515 0260
Fax: +86 10 6515 0263
E-mail: chinainfo@danahermotion.com.cn

Japan

Danaher Motion Japan
2F, Tokyu Reit Hatchobori Bldg
2-7-1 Hatchobori Chuo-ku,
Tokyo 104-0032 Japan
Phone: +81-3-6222-1051
Fax: +81-3-6222-1055
E-mail: info@danahermotion.co.jp

