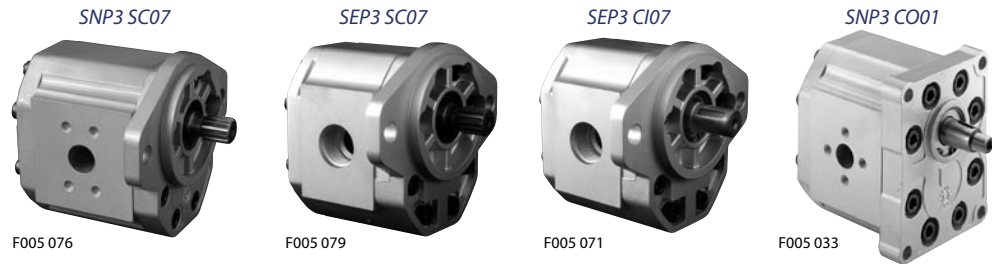

OVERVIEW

The Sauer-Danfoss Group 3 is a range of peak performance fixed-displacement gear pumps. Constructed of a high-strength extruded aluminum body with aluminum cover and flange, all pumps are pressure-balanced for exceptional efficiency.

Some representatives of Group 3 gear pumps:

**FEATURES****Group 3 gear pumps` attributes:**

- Wide range of displacements from 22 to 90 cm³/rev [from 1.34 to 5.49 in³/rev]
- Continuous pressure rating up to 250 bar [3625 psi]
- Speeds up to 3000 min⁻¹ (rpm)
- SAE, DIN and European standard mounting flanges
- High quality case hardened steel gears
- Multiple pump configurations in combination with SNP1, SNP2 and SNP3

© 2005, Sauer-Danfoss. All rights reserved. Printed in Europe.

Sauer-Danfoss accepts no responsibility for possible errors in catalogs, brochures and other printed material. Sauer -Danfoss reserves the right to alter its products without prior notice. This also applies to products already ordered provided that such alterations can be made without affecting agreed specifications. All trademarks in this material are properties of their respective owners. Sauer-Danfoss and the Sauer-Danfoss logotype are trademarks of the Sauer-Danfoss Group.

Front cover illustrations: F005 033, F005 075, F005 071, F005 079, F005 076 and P005 051.

GENERAL INFORMATION	Overview	2
	Features	2
	Pump design	4
	SEP3	4
	SNP3	4
	Technical data	5
	Determination of nominal pump sizes	6
	Metric system	6
	Inch system	6
MODEL CODE DESCRIPTION	Model code	8
SYSTEM REQUIREMENTS	Pressure	10
	Speed	10
	Hydraulic fluids	11
	Temperature and viscosity	11
	Filtration	12
	Filters	12
	Selecting a filter	12
	Reservoir	12
	Line sizing	13
	Pump drive	13
	Pump drive data form	14
	Pump life	15
	Sound levels	15
PUMP PERFORMANCE	Pump performance graphs	16
PRODUCT OPTIONS	Shaft, flange, and port configurations	20
	Shaft options	21
	Mounting flanges	21
	Shaft availability and torque capability	21
	Port configurations	22
	Standard port configurations	22
	Nonstandard port configurations	22
	Porting	24
DIMENSIONS	SNP3 – CI01, SC01 and CO01	26
	SNP3 – CI02, SC02 and CO02	27
	SNP3 – CI03, SC03 and CO03	28
	SNP3 – SC06 and CO06	29
	SNP3 – SC07 and CI07	30

PUMP DESIGN**SEP3**

The SEP3 gear pump is available in a limited displacement range from 22.0 to 44.1 cm³/rev [from 1.34 to 2.69 in³/rev]. Suitable for applications where the pressure is lower than 210 bar [3045 psi], the SEP3 range is released into SAE and European configurations. The overall length is reduced by 12 mm [0.47 in] in respect of the SNP3.

SNP3

The SNP3 is available in the full displacement range from 22.0 to 88.2 cm³/rev [from 1.34 to 5.38 in³/rev], and with higher pressure ratings than the SEP3. This is due to the pressure balance on each side of the gears obtained with pressure-balance plates made in antifriction alloy that contribute to high volumetric efficiency and maximum sealing as well.

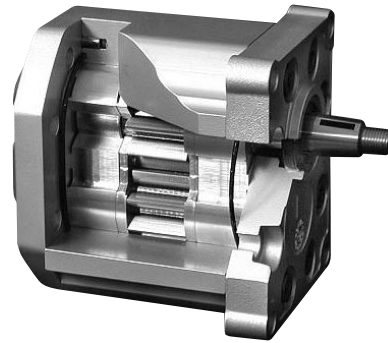
SNP3 CO01 (cut away)

F005 073

TECHNICAL DATA

Specifications for the SNP3 and SEP3 gear pumps

Unit		Frame size									
		22	26	33	38	44	48	55	63	75	90
Displacement	cm ³ /rev [in ³ /rev]	22.1 [1.35]	26.2 [1.60]	33.1 [2.02]	37.9 [2.32]	44.1 [2.69]	48.3 [2.93]	55.1 [3.36]	63.4 [3.87]	74.4 [4.54]	88.2 [5.38]
SNP3											
Peak pressure	bar [psi]	270 [3910]	270 [3910]	270 [3910]	270 [3910]	270 [3910]	250 [3625]	250 [3625]	230 [3350]	200 [2910]	170 [2465]
Rated pressure		250 [3625]	250 [3625]	250 [3625]	250 [3625]	250 [3625]	230 [3350]	230 [3350]	210 [3045]	180 [2610]	150 [2175]
Minimum speed	min ⁻¹ (rpm)	800	800	800	800	800	800	800	600	600	600
Maximum speed		3000	3000	3000	3000	3000	3000	2500	2500	2500	2500
Weight	kg [lb]	6.8 [15.0]	6.8 [15.0]	7.2 [15.8]	7.3 [16.1]	7.5 [16.5]	7.6 [16.8]	7.8 [17.3]	8.1 [17.9]	8.5 [18.7]	8.9 [19.6]
Moment of inertia of rotating components	x 10 ⁻⁶ kg·m ² [x 10 ⁻⁶ lb·ft ²]	198 [4698]	216 [5126]	246 [5838]	267,2 [6340]	294,2 [6891]	312,2 [7408]	342,3 [8123]	378,3 [8977]	426,4 [10118]	486,5 [11545]
Theoretical flow at maximum speed	l/min [US gal/min]	66.3 [17.5]	78.6 [20.8]	99.3 [26.2]	113.7 [30.0]	132.3 [35.0]	144.9 [38.0]	137.8 [36.2]	157.5 [41.5]	186 [49.1]	220.5 [58.3]
SEP3 (01 and 07 configuration)											
Peak pressure	bar [psi]	230 [3350]	230 [3350]	230 [3350]	230 [3350]	200 [2910]					
Rated pressure		210 [3045]	210 [3045]	210 [3045]	210 [3045]	180 [2610]					
Minimum speed	min ⁻¹ (rpm)	1000	1000	1000	1000	800					
Maximum speed		3000	3000	3000	2800	2600					
Weight	kg [lb]	5.7 [12.57]	5.8 [12.79]	6.1 [13.45]	6.2 [13.67]	6.4 [14.11]					
Moment of inertia of rotating components	x 10 ⁻⁶ kg·m ² [x 10 ⁻⁶ lb·ft ²]	198 [4698]	216 [5126]	246 [5873]	294.2 [6981]	312.2 [7408]					
Theoretical flow at maximum speed	l/min [US gal/min]	66.3 [17.5]	78.6 [20.8]	99.3 [26.2]	113.7 [30.0]	132.3 [35.0]					

⚠ Caution

The rated and peak pressure mentioned are for pumps with flanged ports only. When threaded ports are required a de-rated performance has to be considered. To verify the compliance of an high pressure application with a threaded ports pump apply to a Sauer-Danfoss representative.

**DETERMINATION OF
 NOMINAL PUMP SIZES**

Use these formulae to determine the nominal pump size for a specific application:

Metric system

Inch system

<i>Output flow:</i>	$Q = \frac{Vg \cdot n \cdot \eta_v}{1000}$	l/min	$Q = \frac{Vg \cdot n \cdot \eta_v}{231}$	[US gal/min]
<i>Input torque:</i>	$M = \frac{Vg \cdot \Delta p}{20 \cdot \pi \cdot \eta_m}$	Nm	$M = \frac{Vg \cdot \Delta p}{2 \cdot \pi \cdot \eta_m}$	[lbf·in]
<i>Input power:</i>	$P = \frac{M \cdot n}{9550} = \frac{Q \cdot \Delta p}{600 \cdot \eta_t}$	kW	$P = \frac{M \cdot n}{63.025} = \frac{Q \cdot \Delta p}{1714 \cdot \eta_t}$	[hp]

Where:

SI units [US units]

Vg	= Displacement per rev.	cm ³ /rev [in ³ /rev]
Δp	= p _{HD} - p _{ND}	bar [psi]
n	= Speed	min ⁻¹ (rpm)
η _v	= Volumetric efficiency	
η _m	= Mechanical (torque) efficiency	
η _t	= η _v · η _m = Overall efficiency	
p _{HD}	= Outlet pressure	bar [psi]
p _{ND}	= Inlet pressure	bar [psi]



Group 3 Gear Pumps
Technical Information
Notes

MODEL CODE

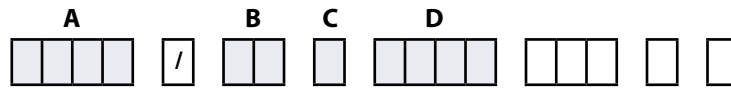

A Type

Code	Description
SNP3	Standard gear pump
SEP3	Medium pressure gear pump

B Displacement

Code	Description	SNP3	SEP3
22	22.1 cm ³ /rev [1.35 in ³ /rev]	●	●
26	26.2 cm ³ /rev [1.60 in ³ /rev]	●	●
33	33.1 cm ³ /rev [2.02 in ³ /rev]	●	●
38	37.9 cm ³ /rev [2.32 in ³ /rev]	●	●
44	44.1 cm ³ /rev [2.69 in ³ /rev]	●	●
48	48.3 cm ³ /rev [2.93 in ³ /rev]	●	–
55	55.1 cm ³ /rev [3.36 in ³ /rev]	●	–
63	63.4 cm ³ /rev [3.87 in ³ /rev]	●	–
75	74.4 cm ³ /rev [4.54 in ³ /rev]	●	–
90	88.2 cm ³ /rev [5.38 in ³ /rev]	●	–

C Direction of rotation

Code	Description	SNP3	SEP3
D	Right (Clockwise)	●	●
S	Left (Counterclockwise)	●	●

D Shaft / Mounting flange / Port configuration

Code	Description	SNP3	SEP3
CO01	1:8 Tapered shaft / European 01 4-bolt flange / European flanged ports	●	●
CO02	1:8 Tapered shaft / European 02 4-bolt flange / European flanged ports	●	–
CO03	1:8 Tapered shaft / European 03 4-bolt flange / European flanged ports	●	–
CO06	1:5 Tapered shaft / German 4-bolt flange / German standard ports	●	–
CI01	Parallel shaft 20 mm [0.787 in] / European 01 4-bolt flange / European flanged ports	●	●
CI02	Parallel shaft 20 mm [0.787 in] / European 02 4-bolt flange / European flanged ports	●	–
CI03	Parallel shaft 22 mm [0.866 in] / European 03 4-bolt flange / European flanged ports	●	–
CI07	Parallel shaft 22.225 mm [0.875 in] / SAE B flange / Vertical 4-bolt flanged ports	●	●
SC01	DIN splined shaft / European 01 4-bolt flange / European flanged ports	●	–
SC02	DIN splined shaft / European 02 4-bolt flange / European flanged ports	●	–
SC03	DIN splined shaft / European 03 4-bolt flange / European flanged ports	●	–
SC06	SAE splined shaft / German 4-bolt flange / German standard ports	●	–
SC07	SAE splined shaft / SAE B flange / Vertical 4-bolt flanged ports	●	●

Legend:	
●	= Standard
○	= Optional
–	= Not Available

MODEL CODE (continued)



E Variant code (3-letter code describes variants to standard configuration)

F Version (value representing a change to the initial project)

Code	Description
.	Initial project [*LEAVE BLANK]
1÷9 or A÷Z	It should be reserved to Sauer-Danfoss

G Port type (if other than standard)

Code	Description
.	Standard port for the flange type specified [*LEAVE BLANK]
A	SAE flanged port
B	Flanged port with threaded holes in X pattern (German standard ports), centered on the body
C	Flanged port with threaded holes in + pattern (European standard ports)
D	Threaded metric port
E	Threaded SAE O-ring boss port
F	Threaded Gas port (BSP)
G	Flanged port with threaded holes in X pattern (German standard ports), offset from center of body

PRESSURE

The inlet vacuum must be controlled in order to realize expected pump life and performance. The system design must meet inlet pressure requirements during all modes of operation. Expect lower inlet pressures during cold start. It should improve quickly as the fluid warms.

Inlet pressure

Maximum continuous vacuum	bar absolute [in. Hg]	0.8 [23.6]
Maximum intermittent vacuum		0.6 [17.7]
Maximum pressure		3.0 [88.5]

Peak pressure is the highest intermittent pressure allowed. The relief valve overshoot (reaction time) determines peak pressure. It is assumed to occur for less than 100 ms. The illustration to the right shows peak pressure in relation to rated pressure and reaction time (100 ms maximum).

Rated pressure is the average, regularly occurring, operating pressure that should yield satisfactory product life. The maximum machine load demand determines rated pressure. For all systems, the load should move below this pressure.

System pressure is the differential between the outlet and inlet ports. It is a dominant operating variable affecting hydraulic unit life. High system pressure, resulting from high load, reduces expected life. System pressure must remain at, or below, rated pressure during normal operation to achieve expected life.

Time versus pressure

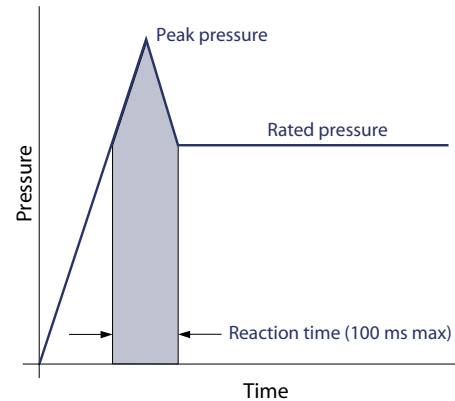

P005 006E

SPEED

Maximum speed is the limit recommended by Sauer-Danfoss for a particular gear pump when operating at rated pressure. It is the highest speed at which normal life can be expected.

The lower limit of operating speed is the **minimum speed**. It is the lowest speed at which normal life can be expected. The minimum speed increases as operating pressure increases. When operating under higher pressures, a higher minimum speed must be maintained, as illustrated to the right:

Speed versus pressure

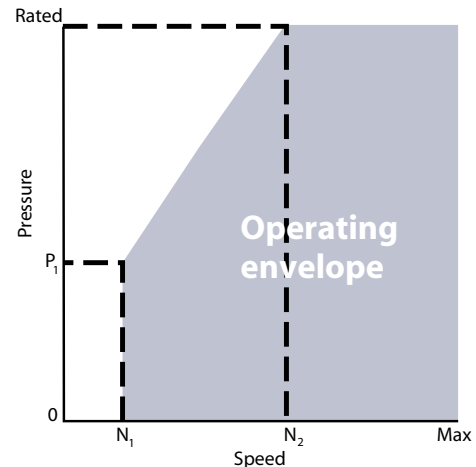

P101 548E

HYDRAULIC FLUIDS

Ratings and data for SNP3 and SEP3 gear pumps are based on operating with premium hydraulic fluids containing oxidation, rust, and foam inhibitors. These fluids must possess good thermal and hydrolytic stability to prevent wear, erosion, and corrosion of internal components. They include:

- Hydraulic fluids following DIN 51524, part 2 (HLP) and part 3 (HVL) specifications
- API CD engine oils conforming to SAE J183
- M2C33F or G automatic transmission fluids
- Certain agricultural tractor fluids

Use only clean fluid in the pump and hydraulic circuit.

Caution

Never mix hydraulic fluids.

Please see Sauer-Danfoss publication *Hydraulic Fluids and Lubricants Technical Information*, 520L0463 for more information. Refer to publication *Experience with Biodegradable Hydraulic Fluids Technical Information*, 520L0465 for information relating to biodegradable fluids.

TEMPERATURE AND VISCOSITY

Temperature and viscosity requirements must be concurrently satisfied. Use petroleum / mineral-based fluids.

High temperature limits apply at the inlet port to the pump. The pump should run at or below the maximum continuous temperature. The peak temperature is based on material properties. Don't exceed it.

Cold oil, generally, doesn't affect the durability of pump components. It may affect the ability of oil to flow and transmit power. For this reason, keep the temperature at 16°C [60 °F] above the pour point of the hydraulic fluid.

Minimum (cold start) temperature relates to the physical properties of component materials.

Minimum viscosity occurs only during brief occasions of maximum ambient temperature and severe duty cycle operation. You will encounter maximum viscosity only at cold start. During this condition, limit speeds until the system warms up. Size heat exchangers to keep the fluid within these limits. Test regularly to verify that these temperatures and viscosity limits aren't exceeded. For maximum unit efficiency and bearing life, keep the fluid viscosity in the recommended viscosity range.

Fluid viscosity

Maximum (cold start)	mm ² /s [SUS]	1000 [4600]
Recommended range		12-60 [66-290]
Minimum		10 [60]

Temperature

Minimum (cold start)	°C [°F]	-20 [-4]
Maximum continuous		80 [176]
Peak (intermittent)		90 [194]

FILTRATION

Filters

Use a filter that conforms to Class 22/18/13 of ISO 4406 (or better). It may be on the pump outlet (pressure filtration), inlet (suction filtration), or reservoir return (return-line filtration).

Selecting a filter

When selecting a filter, please consider:

- contaminant ingress rate (determined by factors such as the number of actuators used in the system)
- generation of contaminants in the system
- required fluid cleanliness
- desired maintenance interval
- filtration requirements of other system components

Measure filter efficiency with a Beta ratio (β_x). For:

- suction filtration, with controlled reservoir ingress, use a $\beta_{35-45} = 75$ filter
- return or pressure filtration, use a pressure filtration with an efficiency of $\beta_{10} = 75$.

β_x ratio is a measure of filter efficiency defined by ISO 4572. It is the ratio of the number of particles greater than a given diameter (x in microns) upstream of the filter to the number of these particles downstream of the filter.

Fluid cleanliness level and β_x ratio

Fluid cleanliness level (per ISO 4406)	Class 22/18/13 or better
β_x ratio (suction filtration)	$\beta_{35-45} = 75$ and $\beta_{10} = 2$
β_x ratio (pressure or return filtration)	$\beta_{10} = 75$
Recommended inlet screen size	100-125 μm [0.004-0.005 in]

The filtration requirements for each system are unique. Evaluate filtration system capacity by monitoring and testing prototypes.

RESERVOIR

The **reservoir** provides clean fluid, dissipates heat, removes entrained air, and allows for fluid volume changes associated with fluid expansion and cylinder differential volumes. A correctly sized reservoir accommodates maximum volume changes during all system operating modes. It promotes deaeration of the fluid as it passes through, and accommodates a fluid dwell-time between 60 and 180 seconds, allowing entrained air to escape.

Minimum reservoir capacity depends on the volume required to cool and hold the oil from all retracted cylinders, allowing for expansion due to temperature changes. A fluid volume of 1 to 3 times the pump output flow (per minute) is satisfactory. The minimum reservoir capacity is 125% of the fluid volume.

Install the suction line above the bottom of the reservoir to take advantage of gravity separation and prevent large foreign particles from entering the line. Cover the line with a 100-125 micron screen. The pump should be below the lowest expected fluid level.

Put the return-line below the lowest expected fluid level to allow discharge into the reservoir for maximum dwell and efficient deaeration. A baffle (or baffles) between the return and suction lines promotes deaeration and reduces fluid surges.

LINE SIZING

Choose pipe sizes that accommodate minimum fluid velocity to reduce system noise, pressure drops, and overheating. This maximizes system life and performance. Design inlet piping that maintains continuous pump inlet pressure above 0.8 bar absolute during normal operation. The line velocity should not exceed the values in this table:

Maximum line velocity

Inlet		2.5 [8.2]
Outlet	m/s [ft/sec]	5.0 [16.4]
Return		3.0 [9.8]

Most systems use hydraulic oil containing 10% dissolved air by volume. Under high inlet vacuum conditions the oil releases bubbles. They collapse when subjected to pressure, resulting in cavitation, causing adjacent metal surfaces to erode. **Over-aeration** is the result of air leaks on the inlet side of the pump, and flow-line restrictions. These include inadequate pipe sizes, sharp bends, or elbow fittings, causing a reduction of flow line cross sectional area. This problem will not occur if inlet vacuum and rated speed requirements are maintained, and reservoir size and location are adequate.

PUMP DRIVE

Shaft options for Group 3 gear pumps include tapered, splined, or parallel shafts. They are suitable for a wide range of direct and indirect drive applications for radial and thrust loads.

Plug-in drives, acceptable only with a splined shaft, can impose severe radial loads when the mating spline is rigidly supported. Increasing spline clearance does not alleviate this condition.

Use plug-in drives if the concentricity between the mating spline and pilot diameter is within 0.1 mm [0.004 in]. Lubricate the drive by flooding it with oil. A 3-piece coupling minimizes radial or thrust shaft loads.

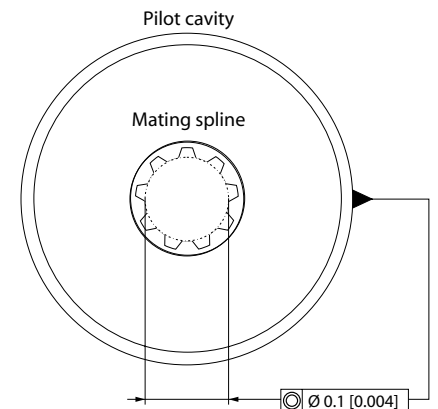

P101 002E

⚠ Caution

In order to avoid spline shaft damages it is recommended to use carburised and hardened steel couplings with 80-82 HRA surface hardness.

Allowable **radial shaft loads** are a function of the load position, load orientation, and operating pressure of the hydraulic pump. All external shaft loads have an effect on bearing life, and may affect pump performance.

In applications where external shaft loads can't be avoided, minimize the impact on the pump by optimizing the orientation and magnitude of the load. Don't use splined shafts for belt or gear drive applications. A spring-loaded belt tension-device is recommended for belt drive applications to avoid excessive tension. Avoid thrust loads in either direction. Contact Sauer-Danfoss if continuously applied external radial or thrust loads occur.

PUMP DRIVE DATA FORM

Photocopy this page and fax the complete form to your Sauer-Danfoss representative for an assistance in applying pumps with belt or gear drive. This illustration shows a pump with counterclockwise orientation:

Optimal radial load position

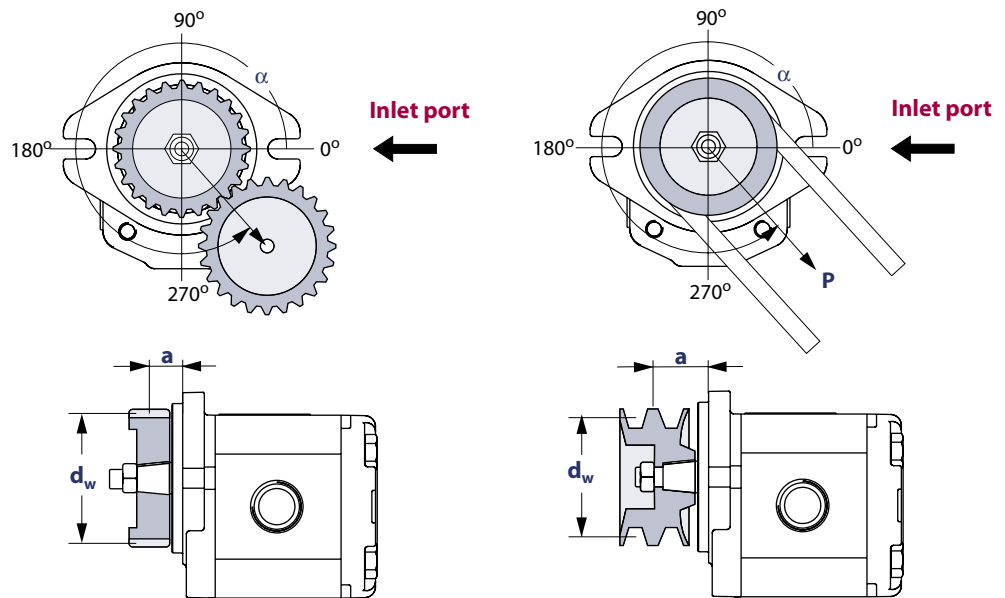

P101 566E

Application data

Item	Value	Unit
Pump displacement		cm ³ /rev [in ³ /rev]
Rated system pressure		<input type="checkbox"/> bar <input type="checkbox"/> psi
Relief valve setting		<input type="checkbox"/> left <input type="checkbox"/> right
Pump shaft rotation		<input type="checkbox"/> left <input type="checkbox"/> right
Pump minimum speed		min ⁻¹ (rpm)
Pump maximum speed		
Drive gear helix angle (gear drive only)		degree
Belt type (gear drive only)		<input type="checkbox"/> V <input type="checkbox"/> notch
Belt tension (gear drive only)	P	<input type="checkbox"/> N <input type="checkbox"/> lbf
Angular orientation of gear or belt to inlet port	α	degree
Pitch diameter of gear or pulley	d_w	<input type="checkbox"/> mm <input type="checkbox"/> in
Distance from flange to center of gear or pulley	a	

PUMP LIFE

Pump life is a function of speed, system pressure, and other system parameters (such as fluid quality and cleanliness).

All Sauer-Danfoss gear pumps use hydrodynamic journal bearings that have an oil film maintained between the gear / shaft and bearing surfaces at all times. If the oil film is sufficiently sustained through proper system maintenance and operating within recommended limits, long life can be expected.

B_{10} life expectancy number is generally associated with rolling element bearings. It does not exist for hydrodynamic bearings.

High pressure, resulting from high loads, impacts pump life. When submitting an application for review, provide machine duty cycle data that includes percentages of time at various loads and speeds. We strongly recommend a prototype testing program to verify operating parameters and their impact on life expectancy before finalizing any system design.

SOUND LEVELS

Noise is unwanted sound. Fluid power systems create noise. There are many techniques available to minimize noise. Understanding how it's generated and transmitted is necessary to apply these methods effectively.

Noise energy is transmitted as fluid borne noise (pressure ripple) or structure borne noise. **Pressure ripple** is the result of the number of pumping elements (gear teeth) delivering oil to the outlet and the pump's ability to gradually change the volume of each pumping element from low to high pressure. Pressure ripple is affected by the compressibility of the oil as each pumping element discharges into the outlet of the pump. Pressure pulsations travel along hydraulic lines at the speed of sound (about 1400 m/s in oil) until there is a change in the system (as with an elbow fitting). Thus, the pressure pulsation amplitude varies with overall line length and position.

Structure borne noise may be transmitted wherever the pump casing is connected to the rest of the system.

The way circuit components respond to excitation depends on their size, form, and mounting. Because of this, a system line may actually have a greater noise level than the pump. To minimize noise, use:

- flexible hoses (if you must use steel plumbing, clamp the lines).
- flexible (rubber) mounts to minimize other structure borne noise.

PUMP PERFORMANCE GRAPHS

The graphs on the next few pages provide typical output flow and input power for Group 3 pumps at various working pressures. Data were taken using ISO VG46 petroleum / mineral based fluid at 50 °C [122 °F] (viscosity = 28 mm²/s [132 SUS]).

SNP3/22 pump performance graph

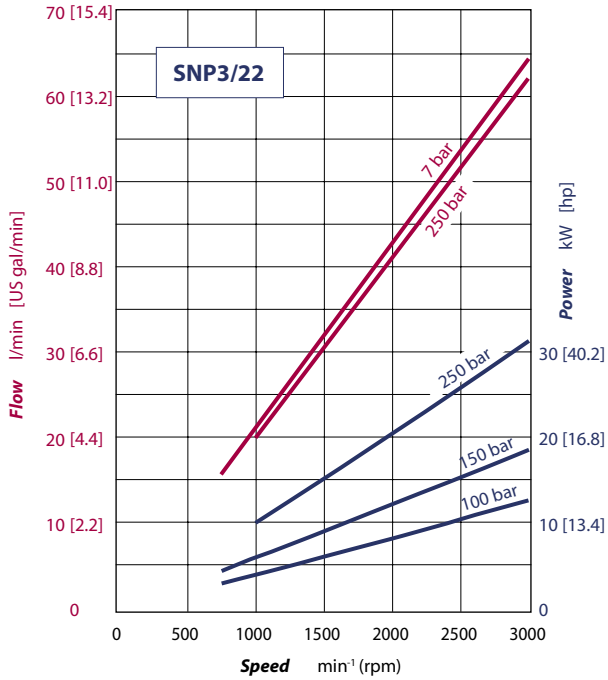

SNP3/26 pump performance graph

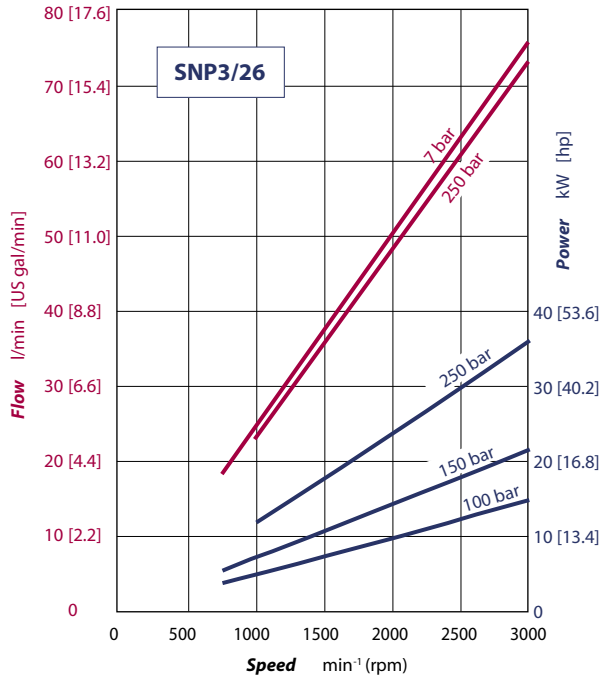

SNP3/33 pump performance graph

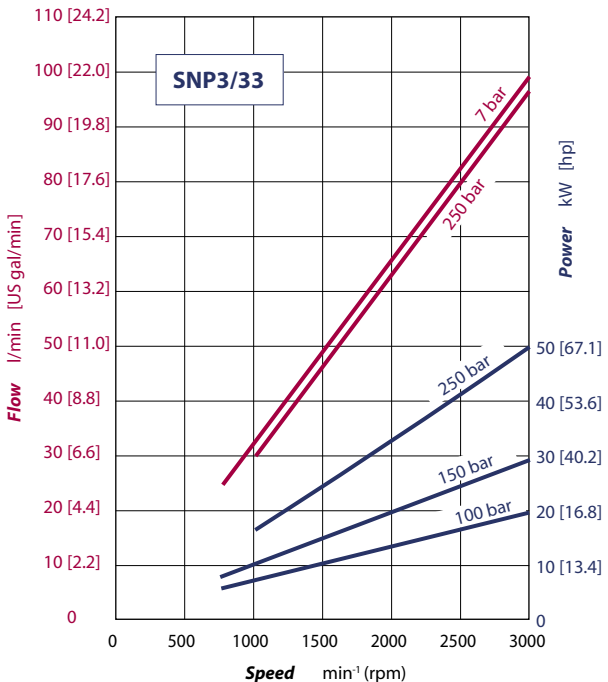

SNP3/38 pump performance graph

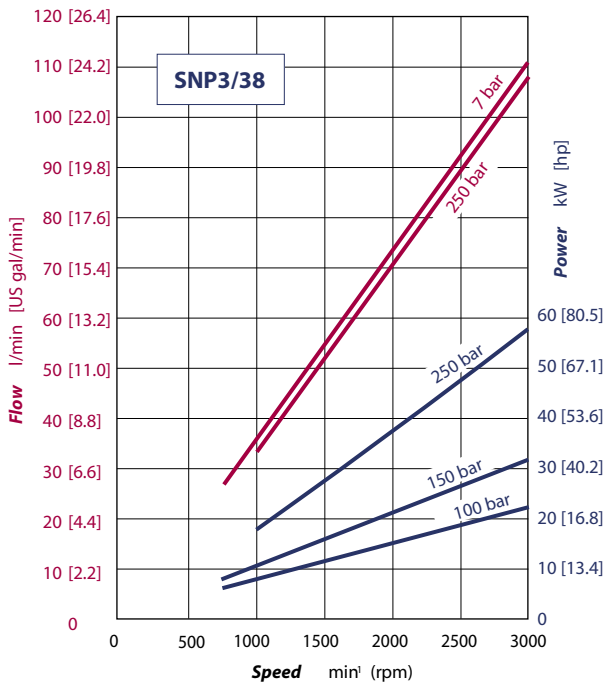

PUMP PERFORMANCE GRAPHS (continued)

SNP3/44 pump performance graph

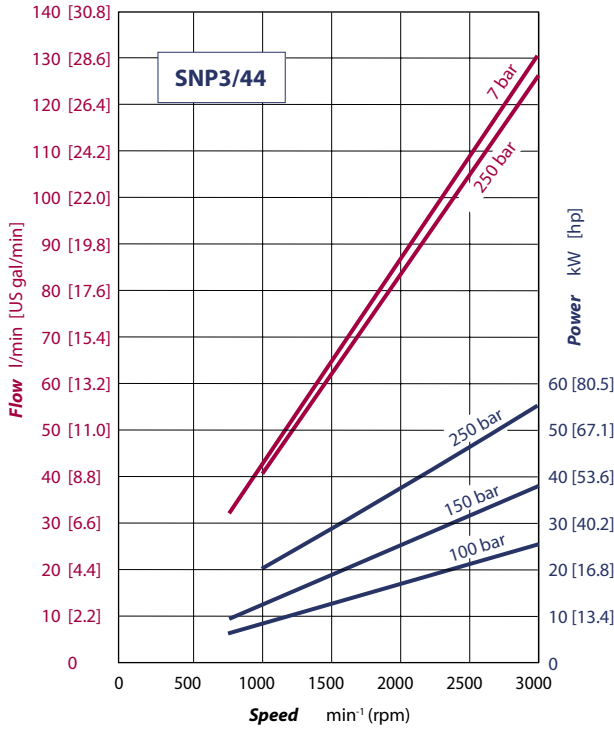

SNP3/48 pump performance graph

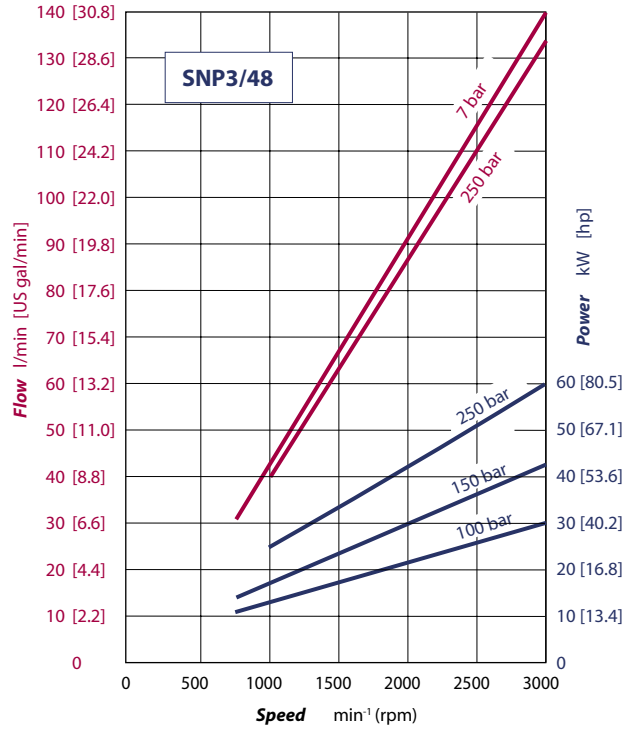

SNP3/55 pump performance graph

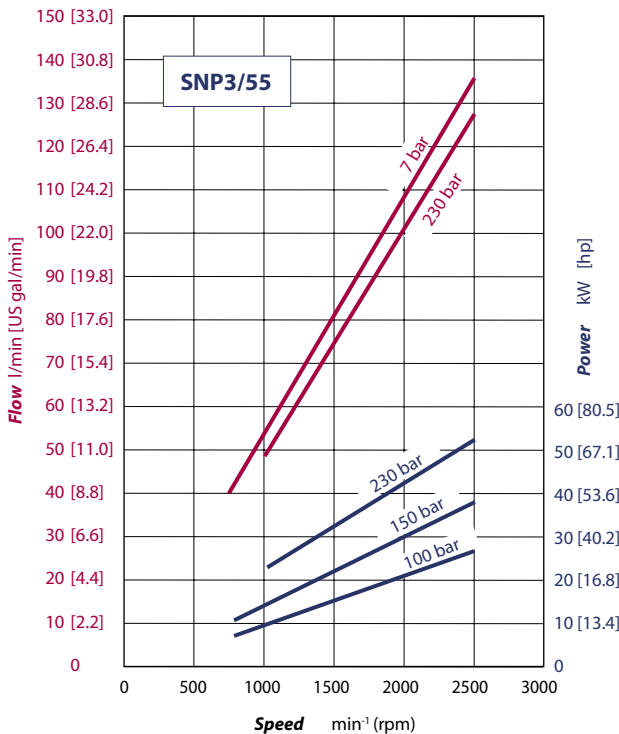

SNP3/63 pump performance graph

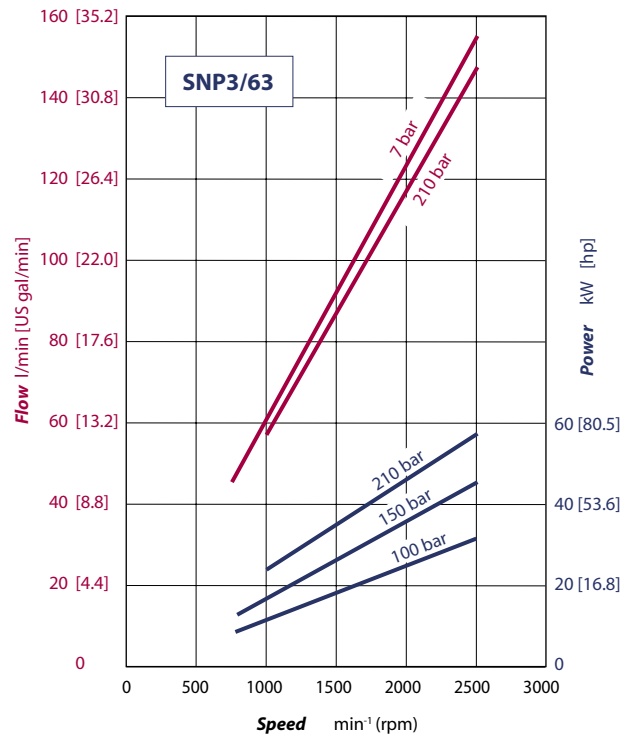

PUMP PERFORMANCE GRAPHS (continued)

SNP3/75 pump performance graph

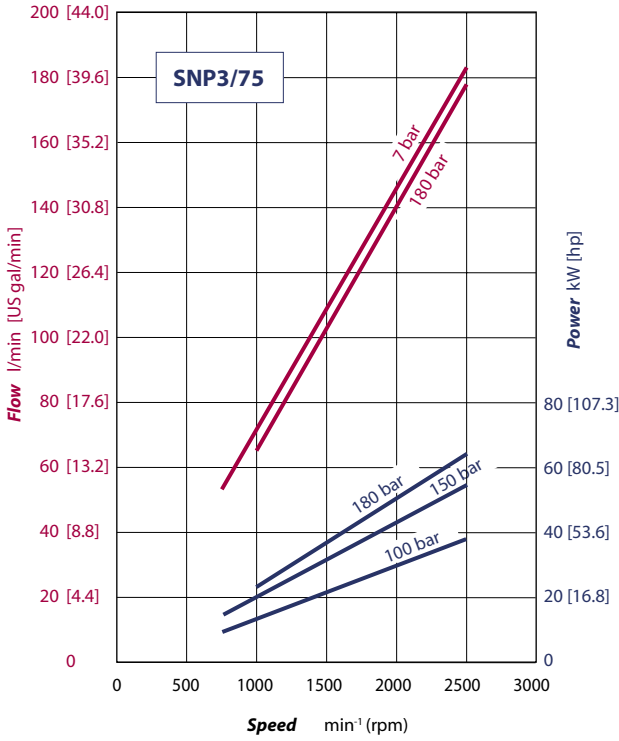

SNP3/90 pump performance graph

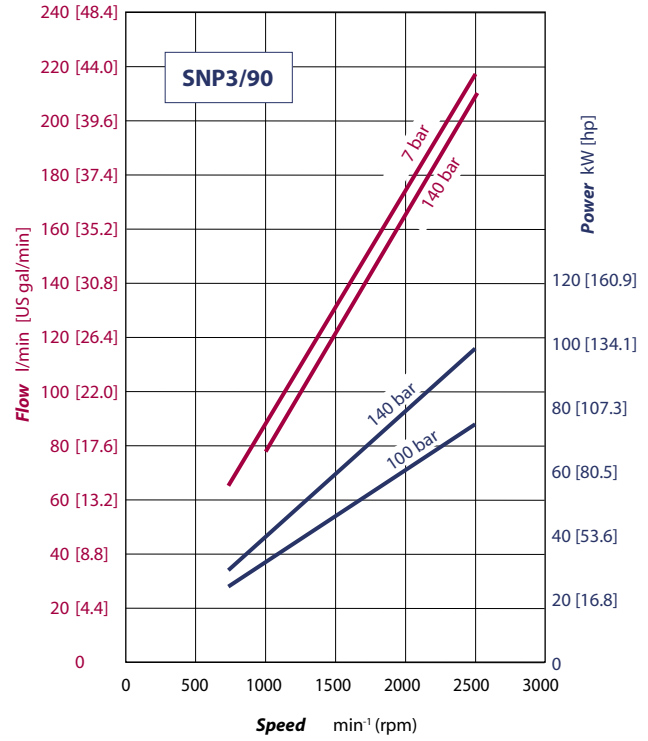

SEP3/22 pump performance graph

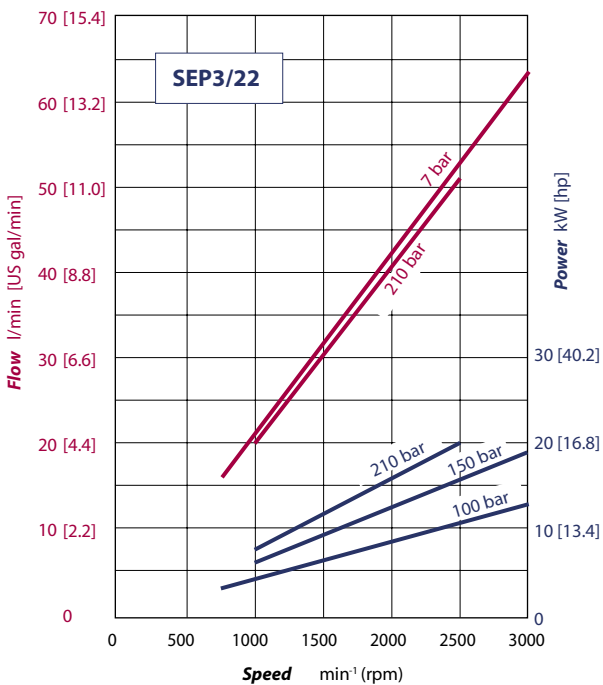

SEP3/26 pump performance graph

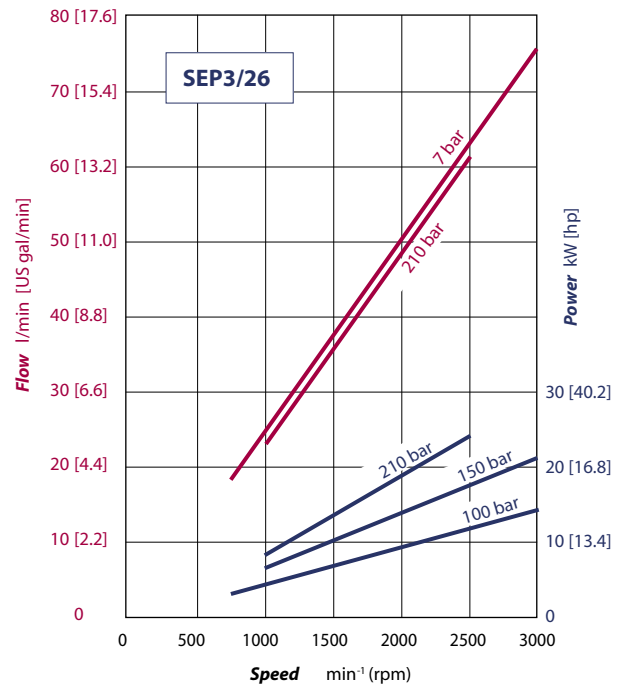

PUMP PERFORMANCE GRAPHS (continued)

SEP3/33 pump performance graph

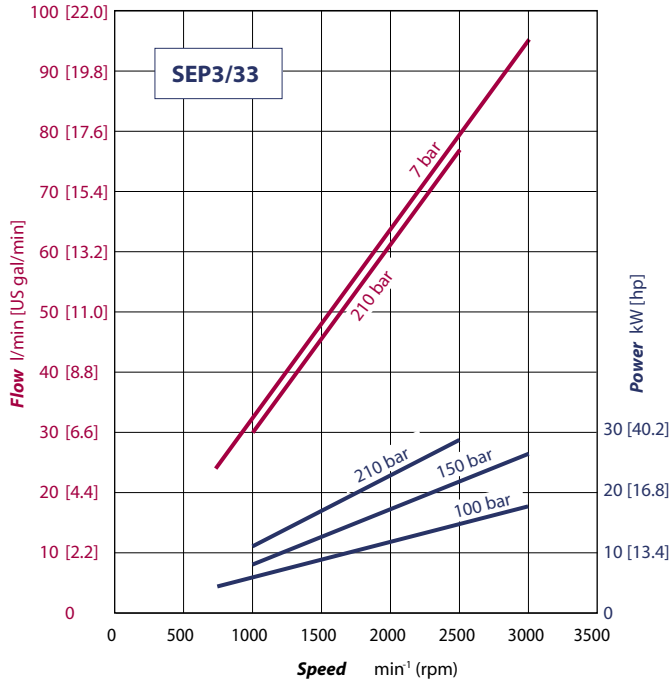



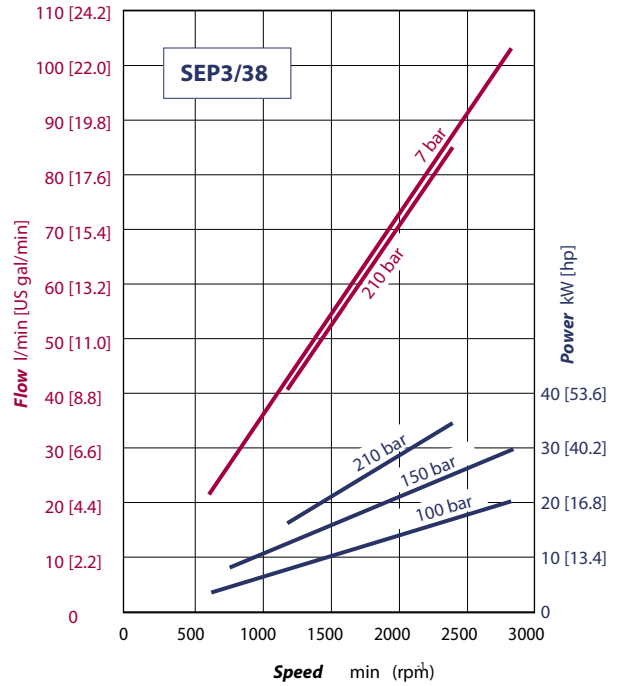

SEP3/38 pump performance graph

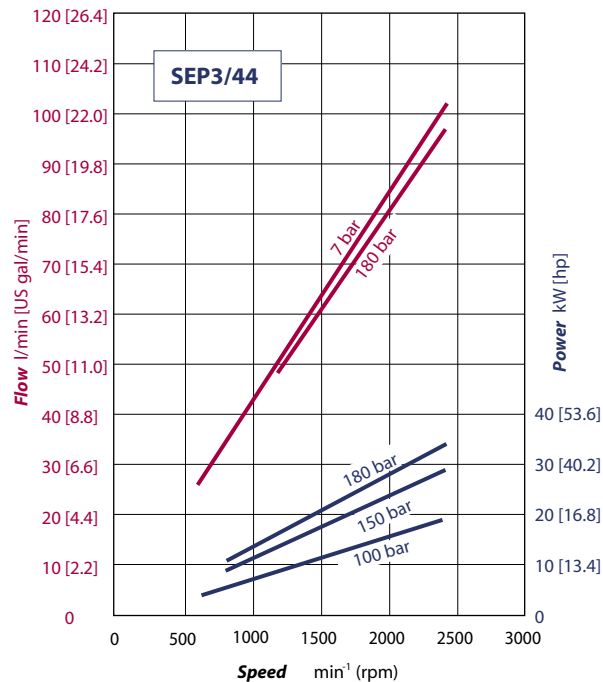

SEP3/44 pump performance graph

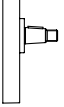
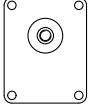
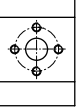
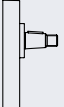
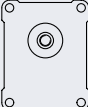
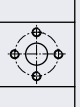
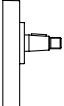
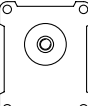
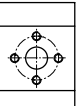
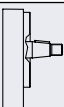

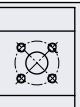
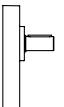
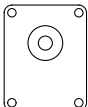
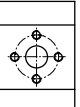
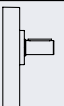
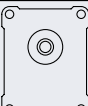
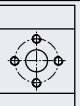
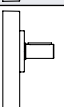
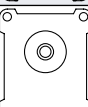
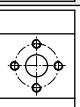
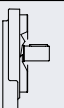
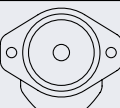
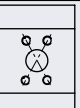
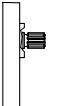
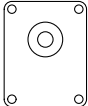
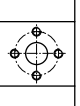
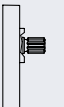
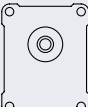
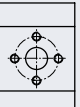
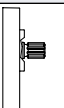
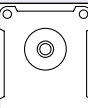
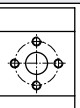
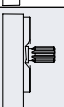
SHAFT, FLANGE, AND PORT CONFIGURATIONS

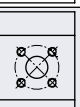
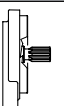
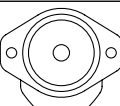
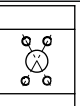
Pump	Code	Shaft	Flange	Port
SEP3 SNP3	CO01	1:8 tapered 	50.8 mm [2.0 in] pilot Ø European 01 4-bolt 	European flanged port + pattern 
SNP3	CO02	1:8 tapered 	50.8 mm [2.0 in] pilot Ø European 02 4-bolt 	European flanged port + pattern 
SNP3	CO03	1:8 tapered 	60.3 mm [2.374 in] pilot Ø European 03 4-bolt 	European flanged port + pattern 
SNP3	CO06	1:5 tapered 	105 mm [4.133 in] pilot Ø German 4-bolt 	German std ports port X pattern 
SEP3 SNP3	CI01	Ø 20 mm [0.787 in] parallel 	50.8 mm [2.0 in] pilot Ø European 01 4-bolt 	European flanged port + pattern 
SNP3	CI02	Ø 20 mm [0.787 in] parallel 	50.8 mm [2.0 in] pilot Ø European 02 4-bolt 	European flanged port + pattern 
SNP3	CI03	Ø 22 mm [0.866 in] parallel 	60.3 mm [2.374 in] pilot Ø European 03 4-bolt 	European flanged port + pattern 
SEP3 SNP3	CI07	Ø 22.225 mm [0.875 in] parallel 	SAE B Ø 101.6 pilot 2-bolt 	Vertical four bolt flanged port 
SNP3	SC01	Splined shaft 13T - m 1.60 DIN 5482-B22x19 	50.8 mm [2.0 in] pilot Ø European 01 4-bolt 	European flanged port + pattern 
SNP3	SC02	Splined shaft 13T - m 1.60 DIN 5482-B22x19 	50.8 mm [2.0 in] pilot Ø European 02 4-bolt 	European flanged port + pattern 
SNP3	SC03	Splined shaft 13T - m 1.60 DIN 5482-B25x22 	60.3 mm [2.374 in] pilot Ø European 03 4-bolt 	European flanged port + pattern 
SNP3	SC06	Splined shaft 13T - m 1.60 DIN 5482-B28x25 	105 mm [4.133 in] pilot Ø German 4-bolt 	German std ports port X pattern 
SEP3 SNP3	SC07	Splined shaft SAE J498 13T - 16/32DP 	SAE B Ø 101.6 pilot 2-bolt 	Vertical four bolt flanged port 

SHAFT OPTIONS

Direction is viewed facing the shaft. Group 3 pumps are available with a variety of splined, parallel, and tapered shaft ends. Not all shaft styles are available with all flange styles.

Valid combinations and nominal torque ratings include:

Shaft availability and torque capability



Description	Shaft Code	Mounting flange code with maximum torque in Nm [lbf·in]				
		01	02	03	06	07
Taper 1:5	CO	-	-	-	300 [2655]	-
Taper 1:8	CO	350 [3097]	350 [3097]	500 [4425]	-	300 [2655]
SAE spline 13T 16/32p	SC	290 [2566]	290 [2566]	380 [3363]	450 [3982]	270 [2389]
Parallel ø 22.225 mm	CI	210 [1858]	210 [1858]	300 [2655]	-	230 [2035]

Sauer-Danfoss recommends mating splines conform to SAE J498 or DIN 5482. Sauer-Danfoss external SAE splines have a flat root side fit with circular tooth thickness reduced by 0.127 mm [0.005 in] in respect to class 1 fit. Dimensions are modified to assure a clearance fit with the mating spline.

Caution

Shaft torque capability may limit allowable pressure. Torque ratings assume no external radial loading. Applied torque must not exceed these limits, regardless of stated pressure parameters. Maximum torque ratings are based on shaft torsional fatigue strength.

MOUNTING FLANGES

Sauer-Danfoss offers many types of industry standard mounting flanges. This table shows order codes for each available mounting flange and its intended use:



Flange code	Intended use
01	European 50.8 mm [2.0 in] 4-bolt
02	
03	European 60.3 mm [2.374 in] 4-bolt
06	German 105 mm [4.134 in] 4-bolt
07	SAE B 2-bolt

PORT CONFIGURATIONS

Standard port configurations

This table lists standard porting offered with each mounting flange:

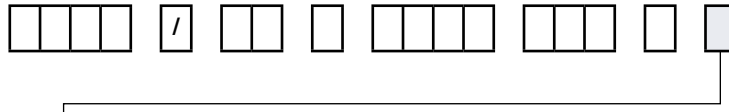

Code	Description	Standard on
C	Flanged port with threaded holes in + pattern (European standard)	01, 02, 03 flanges
G or B	Flanged port with threaded holes in X pattern (German standard ports)	06 flange
A	SAE flanged ports	07 flange

Nonstandard port configurations

Each mounting flange comes with a standard port style. The code is only required when ordering nonstandard ports.

Various port configurations are available on Group 3 pumps. They include:

- European standard flanged ports
- German standard flanged ports
- Gas threaded ports (BSPP)
- O-ring boss (following SAE J1926/1 [ISO 11926-1] UNF threads, standard)

A table of dimensions is on the next page. Here are a few nonstandard port configuration codes:

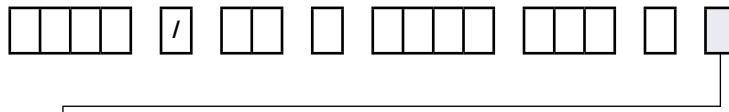

Code	Description
A	SAE flanged port
B	Flanged port with threaded holes in X pattern (German standard), centered on the body
C	Flanged port with threaded holes in + pattern (European standard)
D	Threaded metric port
E	Threaded SAE O-ring boss port
F	Threaded GAS (BSPP)
G	Flanged port with threaded holes in X pattern (German standard), offset from center of the body



Group 3 Gear Pumps
Technical Information
Notes

PORTING

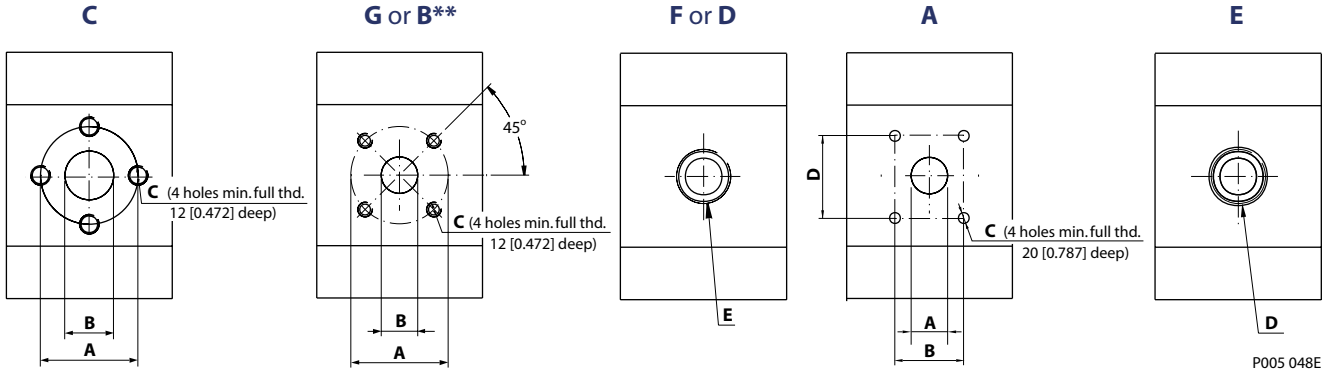

P005 048E

Pump ports dimensions

Model code*		C						G or B**		
Standard port for flange code		01/02			03			06		
Type (displacement)		B	A	C	B	A	C	B	A	C
22	Inlet	20 [0.787]	40 [1.575]	M8	20 [0.787]	40 [1.575]	M8	27 [1.063]	55 [2.165]	M8
	Outlet	20 [0.787]	40 [1.575]	M8	20 [0.787]	40 [1.575]	M8	18 [0.709]	55 [2.165]	M8
26	Inlet	20 [0.787]	40 [1.575]	M8	20 [0.787]	40 [1.575]	M8	27 [1.063]	55 [2.165]	M8
	Outlet	20 [0.787]	40 [1.575]	M8	20 [0.787]	40 [1.575]	M8	18 [0.709]	55 [2.165]	M8
33	Inlet	27 [1.063]	51 [2.008]	M10	27 [1.063]	51 [2.008]	M10	27 [1.063]	55 [2.165]	M8
	Outlet	20 [0.787]	40 [1.575]	M8	20 [0.787]	40 [1.575]	M8	18 [0.709]	55 [2.165]	M8
38	Inlet	27 [1.063]	51 [2.008]	M10	27 [1.063]	51 [2.008]	M10	27 [1.063]	55 [2.165]	M8
	Outlet	20 [0.787]	40 [1.575]	M8	20 [0.787]	40 [1.575]	M8	18 [0.709]	55 [2.165]	M8
44	Inlet	27 [1.063]	51 [2.008]	M10	27 [1.063]	51 [2.008]	M10	27 [1.063]	55 [2.165]	M8
	Outlet	27 [1.063]	51 [2.008]	M10	27 [1.063]	51 [2.008]	M10	18 [0.709]	55 [2.165]	M8
48	Inlet	27 [1.063]	51 [2.008]	M10	27 [1.063]	51 [2.008]	M10	27 [1.063]	55 [2.165]	M8
	Outlet	27 [1.063]	51 [2.008]	M10	27 [1.063]	51 [2.008]	M10	18 [0.709]	55 [2.165]	M8
55	Inlet	27 [1.063]	51 [2.008]	M10	27 [1.063]	51 [2.008]	M10	27 [1.063]	55 [2.165]	M8
	Outlet	27 [1.063]	51 [2.008]	M10	27 [1.063]	51 [2.008]	M10	18 [0.709]	55 [2.165]	M8
63	Inlet	36 [1.417]	62 [2.441]	M10	36 [1.417]	62 [2.441]	M10	36 [1.417]	55 [2.165]	M8
	Outlet	27 [1.063]	51 [2.008]	M10	27 [1.063]	51 [2.008]	M10	27 [1.063]	55 [2.165]	M8
75	Inlet	36 [1.417]	62 [2.441]	M10	36 [1.417]	62 [2.441]	M10	36 [1.417]	55 [2.165]	M8
	Outlet	27 [1.063]	51 [2.008]	M10	27 [1.063]	51 [2.008]	M10	27 [1.063]	55 [2.165]	M8
90	Inlet	36 [1.417]	62 [2.441]	M10	36 [1.417]	62 [2.441]	M10	36 [1.417]	55 [2.165]	M8
	Outlet	27 [1.063]	51 [2.008]	M10	27 [1.063]	51 [2.008]	M10	27 [1.063]	55 [2.165]	M8

(the table is continued on the next page)

* Mark only if desired porting is nonstandard for the flange code selected. Otherwise, mark .

** Port B is in the center of the body. Port G is offset from the center of the body.

PORTING (continued)

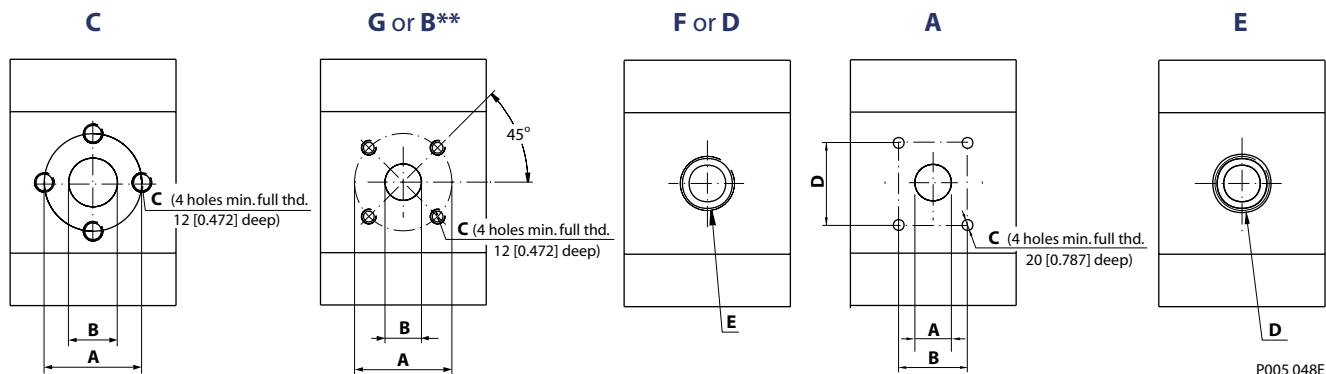

P005 048E

Pump ports dimensions (continued)

Model code*		A			F or D		E	
Standard port for flange code		07/08/09			nonstandard for all configuration		07/08/09	
Type (displacement)		A	B	D	C	E	D	
22	Inlet	25.4 [1.000]	26.19 [1.031]	52.37 [2.062]	3/8-16UNC-2B	3/4 Gas (BSPP)	M26x1.5	1 5/16-12UN-2B
	Outlet	19.1 [0.752]	22.23 [0.875]	47.63 [1.875]	3/8-16UNC-2B	3/4 Gas (BSPP)	M26x1.5	1 1/16-12UN-2B
26	Inlet	25.4 [1.000]	26.19 [1.031]	52.37 [2.062]	3/8-16UNC-2B	3/4 Gas (BSPP)	M26x1.5	1 5/16-12UN-2B
	Outlet	19.1 [0.752]	22.23 [0.875]	47.63 [1.875]	3/8-16UNC-2B	3/4 Gas (BSPP)	M26x1.5	1 1/16-12UN-2B
33	Inlet	31.8 [1.252]	30.18 [1.188]	58.72 [2.312]	7/16-14UNC-2B	1 Gas (BSPP)	M33x2	1 5/8-12UN-2B
	Outlet	25.4 [1.000]	26.19 [1.031]	52.37 [2.062]	3/8-16UNC-2B	3/4 Gas (BSPP)	M26x1.5	1 5/16-12UN-2B
38	Inlet	31.8 [1.252]	30.18 [1.188]	58.72 [2.312]	7/16-14UNC-2B	1 Gas (BSPP)	M33x2	1 5/8-12UN-2B
	Outlet	25.4 [1.000]	26.19 [1.031]	52.37 [2.062]	3/8-16UNC-2B	3/4 Gas (BSPP)	M26x1.5	1 5/16-12UN-2B
44	Inlet	31.8 [1.252]	30.18 [1.188]	58.72 [2.312]	7/16-14UNC-2B	1 Gas (BSPP)	M33x2	1 5/8-12UN-2B
	Outlet	25.4 [1.000]	26.19 [1.031]	52.37 [2.062]	3/8-16UNC-2B	1 Gas (BSPP)	M33x2	1 5/16-12UN-2B
48	Inlet	31.8 [1.252]	30.18 [1.188]	58.72 [2.312]	7/16-14UNC-2B	1 Gas (BSPP)	M33x2	1 5/8-12UN-2B
	Outlet	25.4 [1.000]	26.19 [1.031]	52.37 [2.062]	3/8-16UNC-2B	1 Gas (BSPP)	M33x2	1 5/16-12UN-2B
55	Inlet	38.1 [1.500]	35.71 [1.406]	69.85 [2.750]	1/2-13UNC-2B	1 Gas (BSPP)	M33x2	1 7/8-12UN-2B
	Outlet	31.8 [1.252]	30.18 [1.188]	58.72 [2.312]	7/16-14UNC-2B	1 Gas (BSPP)	M33x2	1 5/8-12UN-2B
63	Inlet	38.1 [1.500]	35.71 [1.406]	69.85 [2.750]	1/2-13UNC-2B	1 1/4 Gas (BSPP)	M42x2	1 7/8-12UN-2B
	Outlet	31.8 [1.252]	30.18 [1.188]	58.72 [2.312]	7/16-14UNC-2B	1 Gas (BSPP)	M33x2	1 5/8-12UN-2B
75	Inlet	38.1 [1.500]	35.71 [1.406]	69.85 [2.750]	1/2-13UNC-2B	1 1/4 Gas (BSPP)	M42x2	1 7/8-12UN-2B
	Outlet	31.8 [1.252]	30.18 [1.188]	58.72 [2.312]	7/16-14UNC-2B	1 Gas (BSPP)	M33x2	1 5/8-12UN-2B
90	Inlet	38.1 [1.500]	35.71 [1.406]	69.85 [2.750]	1/2-13UNC-2B	1 1/4 Gas (BSPP)	M42x2	1 7/8-12UN-2B
	Outlet	31.8 [1.252]	30.18 [1.188]	58.72 [2.312]	7/16-14UNC-2B	1 Gas (BSPP)	M33x2	1 5/8-12UN-2B

* Mark only if desired porting is nonstandard for the flange code selected. Otherwise, mark.

** Port B is in the center of the body. Port G is offset from the center of the body.

SNP3 – CI01, SC01 AND CO01

Standard porting

The drawing shows the SNP3 standard porting for CI01, SC01 and CO01. The configurations CI01 and CO01 are available for the SEP3. The SEP3 overall length is 12 mm [0.472 in] less than the SNP3 for the whole range of displacements (22.1 to 44.1 cm³/rev [1.35 to 2.69 in³/rev]).

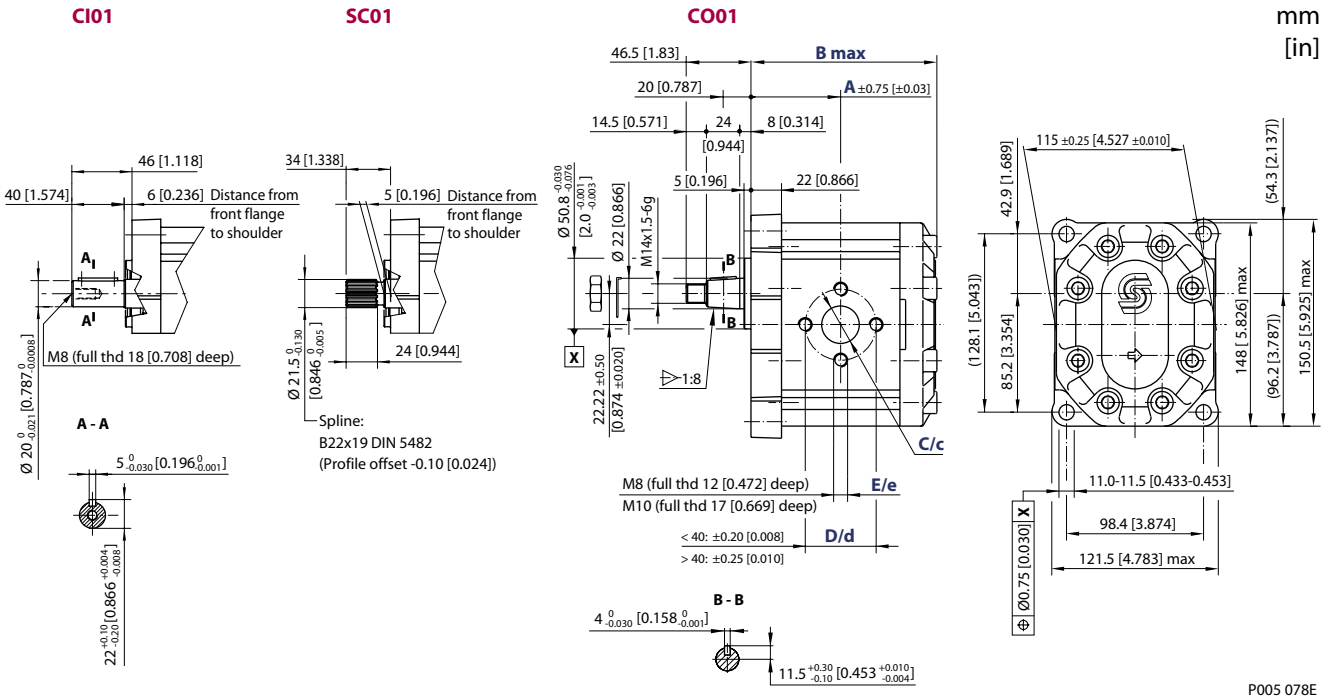

P005 078E

SNP3 – CI01, SC01 and CO01 dimensions

Type (displacement)	22	26	33	38	44	48	55	63	75	90	
Dimension	A	63.0 [2.480]	64.5 [2.539]	67.0 [2.637]	68.8 [2.708]	71.0 [2.795]	72.5 [2.854]	75.0 [2.952]	78.0 [3.070]	82.0 [3.228]	87.0 [3.425]
	B	132.5 [5.216]	135.5 [5.334]	140.5 [5.531]	144.0 [5.669]	148.5 [5.846]	151.5 [5.964]	156.5 [6.161]	162.5 [6.397]	170.5 [6.712]	180.5 [7.106]
Inlet	C	20 [0.787]		27 [1.063]			36 [1.417]				
	D	40 [1.575]		51 [2.007]			62 [2.441]				
	E	M8			M10						
Outlet	c	20 [0.787]				27 [1.063]					
	d	40 [1.575]				51 [2.001]					
	e	M8				M10					

Model code example

SNP3	SNP3/22 D CI01 ...
	SNP3/38 S SC01 ...
	SNP3/75 D CO01 ...
SEP3	SEP3/22 S CI01 ...
	SEP3/44 D CO01 ...

Maximum shaft torque

CI01	N·m [lbf·in]	210 [1858]
SC01		290 [2566]
CO01		350 [3097]

For further details on ordering, see *Model code*, pages 8 and 9.

SNP3 – CI02, SC02 AND CO02

Standard porting

The drawing shows the SNP3 standard porting for CI02, SC02 and CO02.

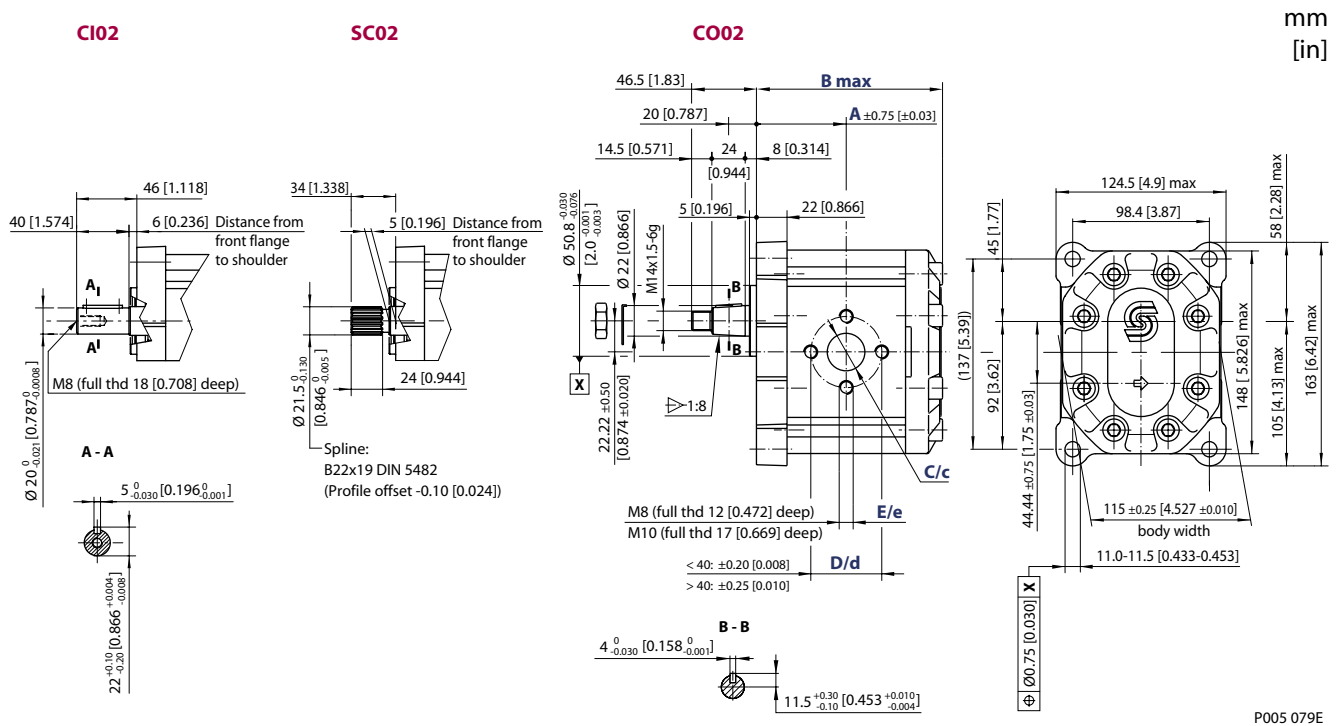

P005 079E

SNP3 – CI02, SC02 and CO02 dimensions

Type (displacement)		22	26	33	38	44	48	55	63	75	90
Dimension	A	63.0 [2.480]	64.5 [2.539]	67.0 [2.637]	68.8 [2.708]	71.0 [2.795]	72.5 [2.854]	75.0 [2.952]	78.0 [3.070]	82.0 [3.228]	87.0 [3.425]
	B	132.5 [5.216]	135.5 [5.334]	140.5 [5.531]	144.0 [5.669]	148.5 [5.846]	151.5 [5.964]	156.5 [6.161]	162.5 [6.397]	170.5 [6.712]	180.5 [7.106]
Inlet	C	20 [0.787]			27 [1.063]			36 [1.417]			
	D	40 [1.575]			51 [2.007]			62 [2.441]			
	E	M8						M10			
Outlet	c	20 [0.787]						27 [1.063]			
	d	40 [1.575]						51 [2.001]			
	e	M8						M10			

Model code example

SNP3	SNP3/22 D CI02 ...
	SNP3/38 S SC02 ...
	SNP3/75 D CO02 ...

Maximum shaft torque

CI02	N·m [lbf·in]	210 [1858]
SC02		290 [2566]
CO02		350 [3097]

For further details on ordering, see *Model code*, pages 8 and 9.

SNP3 – CI03, SC03 AND CO03

Standard porting

The drawing shows the SNP3 standard porting for CI03, SC03 and CO03.

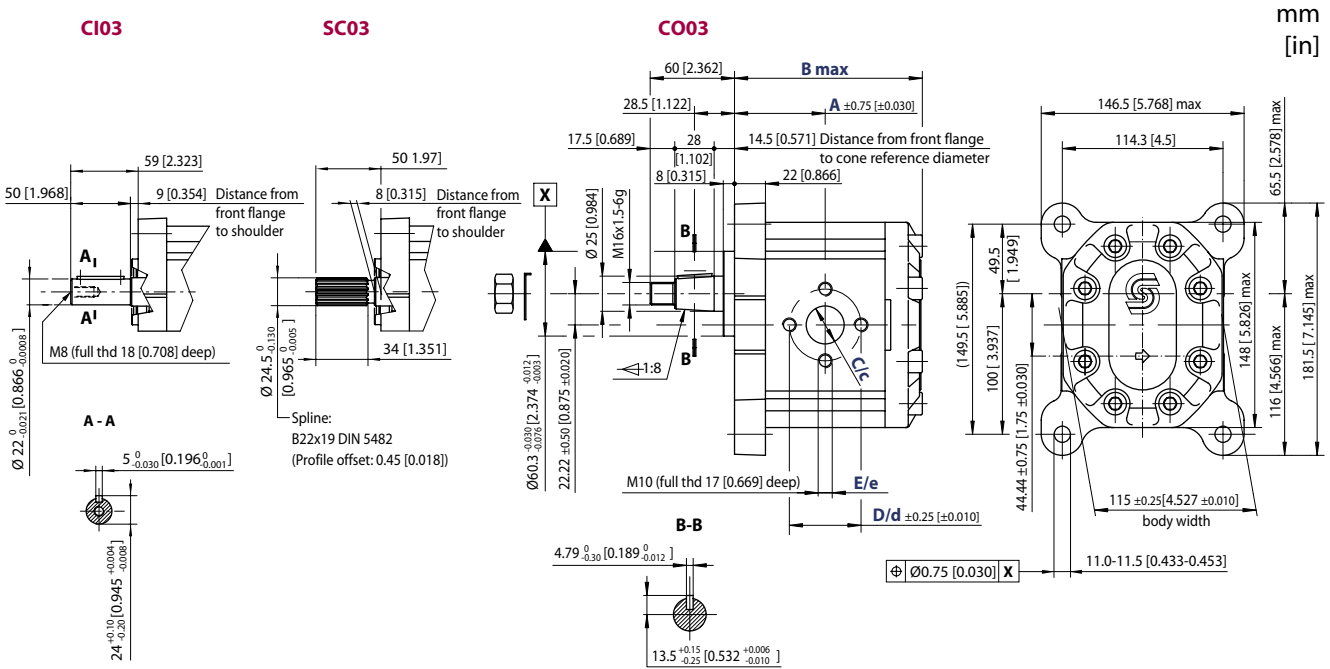

P005 080 E

SNP3 – CI03, SC03 and CO03 dimensions

Type (displacement)	22	26	33	38	44	48	55	63	75	90	
Dimension	A	63.0 [2.480]	64.5 [2.539]	67.0 [2.637]	68.8 [2.708]	71.0 [2.795]	72.5 [2.854]	75.0 [2.952]	78.0 [3.070]	82.0 [3.228]	87.0 [3.425]
	B	132.5 [5.216]	135.5 [5.334]	140.5 [5.531]	144.0 [5.669]	148.5 [5.846]	151.5 [5.964]	156.5 [6.161]	162.5 [6.397]	170.5 [6.712]	180.5 [7.106]
Inlet	C	20 [0.787]		27 [1.063]			36 [1.417]				
	D	40 [1.575]		51 [2.007]			62 [2.441]				
	E	M8		M10			M10				
Outlet	c	20 [0.787]			27 [1.063]						
	d	40 [1.575]			51 [2.001]						
	e	M8			M10						

Model code example

SNP3	SNP3/22 D CI03 ...
	SNP3/38 S SC03 ...
	SNP3/75 D CO03 ...

Maximum shaft torque

CI03	N•m [lbf•in]	300 [2655]
SC03		380 [3363]
CO03		500 [4425]

For further details on ordering, see *Model code*, pages 8 and 9.

SNP3 – SC06 AND CO06

Standard porting

The drawing shows the SNP3 standard porting for SC06 and CO06.

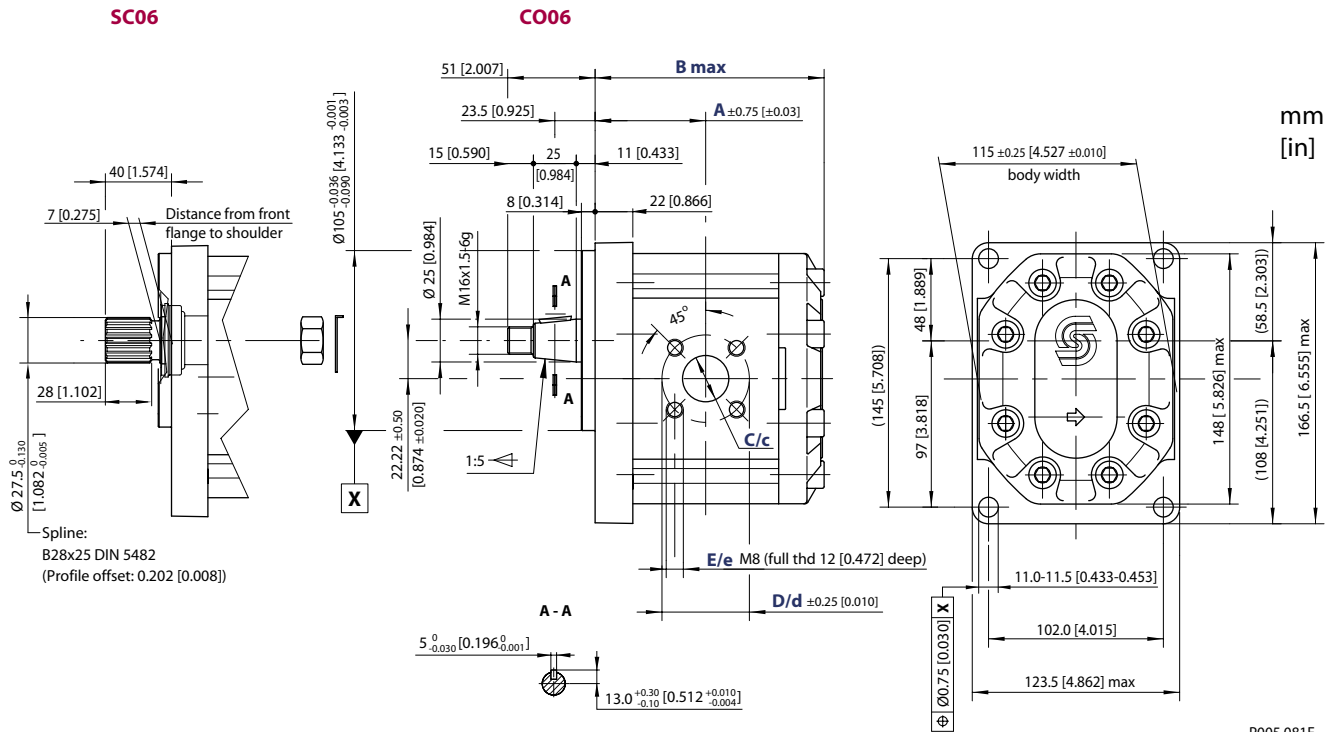

P005 081E

SNP3 – SC06 and CO06 dimensions

Type (displacement)		22	26	33	38	44	48	55	63	75	90
Dimension	A	63.0 [2.480]	64.5 [2.539]	67.0 [2.637]	68.8 [2.708]	71.0 [2.795]	72.5 [2.854]	75.0 [2.952]	78.0 [3.070]	82.0 [3.228]	87.0 [3.425]
	B	132.5 [5.216]	135.5 [5.334]	140.5 [5.531]	144.0 [5.669]	148.5 [5.846]	151.5 [5.964]	156.5 [6.161]	162.5 [6.397]	170.5 [6.712]	180.5 [7.106]
Inlet	C	27 [1.063]						36 [1.417]			
	D	55 [2.165]									
	E	M8									
Outlet	c	18 [0.708]						27 [1.063]			
	d	55 [2.165]									
	e	M8									

Model code example

SNP3	SNP3/38 S SC06 ... SNP3/55 D CO06 ...
-------------	--

Maximum shaft torque

SC06	N·m [lbf·in]	450 [3982]
CO06		300 [2655]

For further details on ordering, see *Model code*, pages 8 and 9.

SNP3 – SC07 AND CI07

Standard porting

The drawing shows the SNP3 standard porting for SC07 and CI07.

The same configurations are available for the **SEP3**. The SEP3 overall length is 12 mm [0.472 in] less than the SNP3 for the whole range of displacements (22.1 to 44.1 cm³/rev [1.35 to 2.69 in³/rev]).

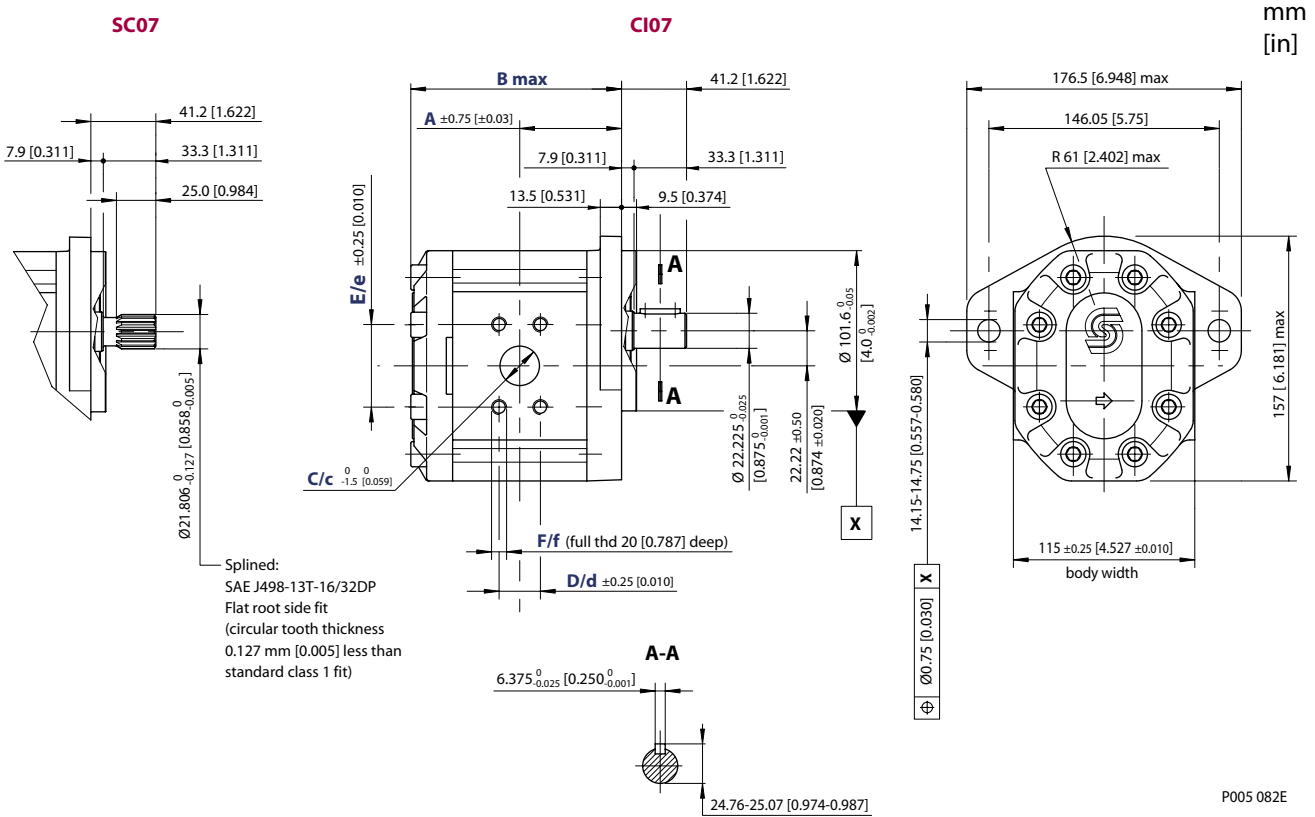

SNP3 – SC07 and CI07 dimensions

Type (displacement)	22	26	33	38	44	48	55	63	75	90	
Dimension	A	63.0 [2.480]	64.5 [2.539]	67.0 [2.637]	68.8 [2.708]	71.0 [2.795]	72.5 [2.854]	75.0 [2.952]	78.0 [3.070]	82.0 [3.228]	87.0 [3.425]
	B	132.5 [5.216]	135.5 [5.334]	140.5 [5.531]	144.0 [5.669]	148.5 [5.846]	151.5 [5.964]	156.5 [6.161]	162.5 [6.397]	170.5 [6.712]	180.5 [7.106]
Inlet	C	25.4 [1]		31.8 [1.251]			38.1 [1.5]				
	D	26.19 [1.031]		30.18 [1.188]			35.71 [1.405]				
	E	52.37 [2.061]		58.72 [2.311]			69.85 [2.75]				
	F	3/8-16UNC-2B		7/16-14UNC-2B			1/2-13UNC-2B				
Outlet	c	19.1 [0.751]		25.4 [1]			31.8 [1.251]				
	d	22.23 [0.875]		26.19 [1.031]			30.18 [1.188]				
	e	47.63 [1.875]		52.37 [2.061]			58.72 [2.311]				
	f	3/8-16UNC-2B		3/8-16UNC-2B			7/16-14UNC-2B				

**SNP3 – SC07 AND CI07
 (continued)**

Model code example

SNP3	SNP3/90 D SC07 ... SNP3/38 S CI07 ...
SEP3	SEP3/22 S SC07 ... SEP3/26 D CI07 ...

Maximum shaft torque

SC07	N·m [lbf·in]	270 [2389]
CI07		230 [2035]

For further details on ordering, see *Model code*, pages 8 and 9.



OUR PRODUCTS

Hydrostatic transmissions
Hydraulic power steering
Electric power steering
Electrohydraulic power steering
Closed and open circuit axial piston pumps and motors
Gear pumps and motors
Bent axis motors
Orbital motors
Transit mixer drives
Planetary compact gears
Proportional valves
Directional spool valves
Cartridge valves
Hydraulic integrated circuits
Hydrostatic transaxles
Integrated systems
Fan drive systems
Electrohydraulic controls
Digital electronics and software
Electric motors and inverters
Joysticks and control handles
Displays
Sensors

Sauer-Danfoss Hydraulic Power Systems – Market Leaders Worldwide

Sauer-Danfoss is a comprehensive supplier providing complete systems to the global mobile market.

Sauer-Danfoss serves markets such as agriculture, construction, road building, material handling, municipal, forestry, turf care, and many others.

We offer our customers optimum solutions for their needs and develop new products and systems in close cooperation and partnership with them.

Sauer-Danfoss specializes in integrating a full range of system components to provide vehicle designers with the most advanced total system design.

Sauer-Danfoss provides comprehensive worldwide service for its products through an extensive network of Authorized Service Centers strategically located in all parts of the world.

Sauer-Danfoss (US) Company
2800 East 13th Street
Ames, IA 50010, USA
Phone: +1 515 239-6000, Fax: +1 515 239 6618

Sauer-Danfoss (Neumünster) GmbH & Co. OHG
Postfach 2460, D-24531 Neumünster
Krokamp 35, D-24539 Neumünster, Germany
Phone +49 4321 871-0, Fax: +49 4321 871 122

Sauer-Danfoss (Nordborg) ApS
DK-6430 Nordborg, Denmark
Phone: +45 7488 4444, Fax: +45 7488 4400

www.sauer-danfoss.com