

Magnetic Sensor

Magnetic Sensor & Proximity Switch

Magnetic switch (sensor) ordering code

JRTM — R — 3M — EX

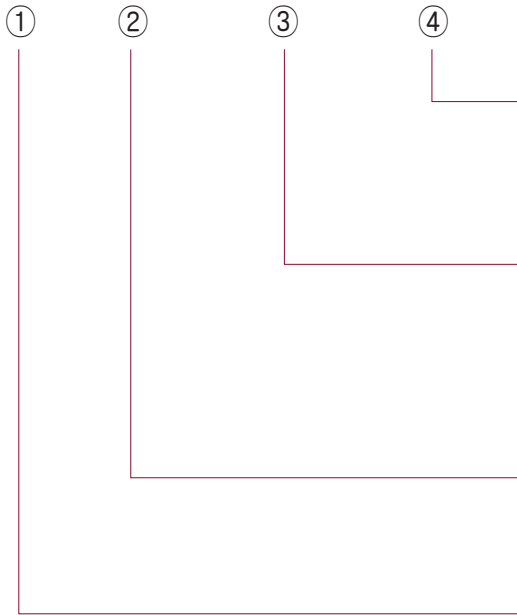

④	Ex Mark	None : Standard type
		EX : Flame-proof type
③	Cable Length	None = Cable length = 1m
		Cable length = 3m
		Cable length = 5m
		M8-3p male quick connector (Cable length is 0.15m)
②	Sensor type	R : Reed switch 2 wire type
		N : Solid state type,current sinking
		P : Solid state type,current sourcing
		RT : High temperature type (125 °C)
①	Product Name	JRTM, JRT-02, JRT-03, JRT-34

Proximity switch(sensor) ordering code

JPM8S — R — 3M

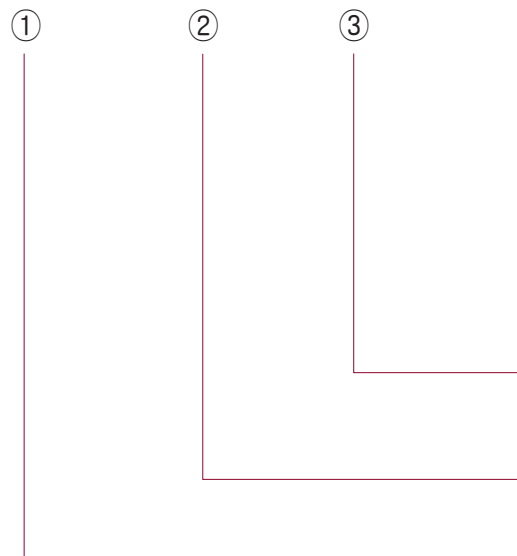

③	Cable Length	None : Cable length is 1M (Standard)
		Cable length is 3M
②	Sensor type	None:Solid state NPN type,current sinking (3 wire)
		Solid state PNP type,current sourcing (3 wire)
①	Product Name	JPM8,JPM8S,JPM12

Magnetic Sensor

Magnetic Sensor & Proximity Switch

Magnetic Sensor Specification

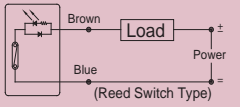
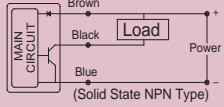
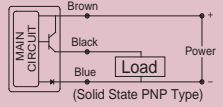
CHARACTERISTIC \ TYPE	Reed Switch	NPN Type	PNP Type
Switching Logic	SPST Normaliy Open	Solid State Output, Normally Open	
Sensor Type	Reed Switch	NPN Current Sourcing	PNP Current Sourcing
Operating Voltage -Note 1.	JRTM, JRT-02 5~120V DC/AC	5~28V DC	
	JRT-03, 34 5~240V DC/AC		
Switching Current	100mA max.	200mA max.	
Switching Rating	5 W max.	20 W max.	
Voltage Drop	2.5V max. @ 40mA~100mA DC	1.5 V max. @ 200mA DC(Resistive Load)	
Leakage Current	-	0.01 mA max.	
Current Consumption	-----	15~20 mA max.	16~18 mA max.
Indicator	Red LED	Red LED	Green LED
Cable	2C,Oil Resident PVC	2C,Oil Resident PVC	
	JRTM PU		
Max. Switching Frequency	200 Hz	1000 Hz	
Temperature Range	-10~70 °C		
Shock -Note 2.	30G	50G	
Vibration -Note 3.	9G		
Insulation Resistance	100M(Measured by 500V DC Mega between Lead to Case)		
Dielectric Strength	1500V AC rms for 1 minute or 1800V DC rms for 1second(Lead to Case)		
Enclosure Classification	IP 67 (NEMA 6)		
Protection Circuit	None	Power Source Reverse Polarrity; Surge Suppression	
CE Certificate No.	No. E8 04 07 53334 001	No. E8 04 07 53334 003	No. E8 04 07 53334 002
3C Certificate No.	No.:2004010305127433	-	
CNEx Certificate No.	CNEx05. 1366X(ExnCIICT6)	CNEx05. 0842 (ExialIBT6)	
Connect Diagram	 <p>Reed Switch</p>	 <p>NPN Type</p>	 <p>PNP Type</p>

► Note

1. The max. operating voltage of T-□□R-QD8 is 60V AC/DC (Based on IEC61076-2-101).
2. Sin Wave / X、 Y、 Z 3 Directions / 3 Times Each Direction / 11mS Each Time.
3. Double Amplitude 1.5mm / 10Hz~55Hz~10Hz(Sweep 1min) / X、 Y、 Z
3 Directions / 1Hour Each Time.
4. Measuring standard target: 15.5 x 8 x 5t(Anisotropic Rubber Magnet).
5. We reserve the right to make changes without notice.

QUICK CONNECTOR_{m8,m12}

Note. The dimensions of plastic which with cable is for reference

<< SENSOR >>

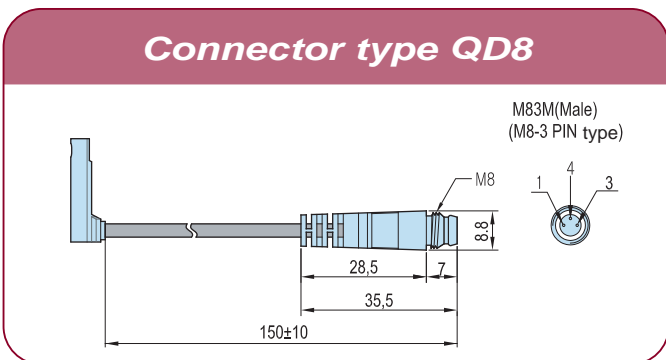
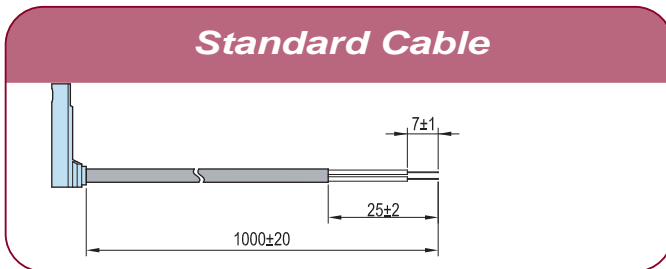

<< Connector >>

M8,M12 CONNECTOR DIMENSION

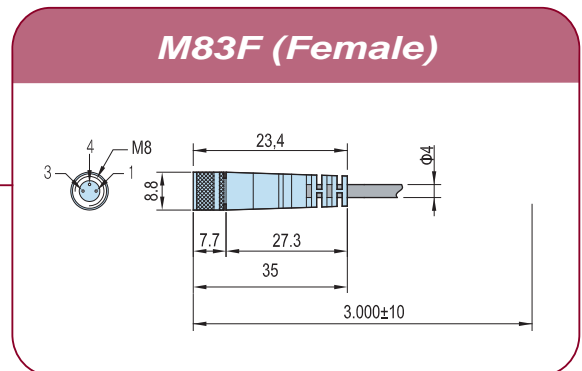

Specification

Characteristic	Type	M83F
Connector Type		M8 3PIN Female (Straight)
Lead Wire Color		PIN 1:Brown, PIN 3:Blue, PIN 4:Black
Max. Operating Voltage		60V AC/DC
Max. Rating Current		3A
Insulation Between Contacts		1.0KV
Insulation Between Contacts & Metal Housing		0.85KV
Pin Coating		5M GOLD COATING
Numbers Of Mechanical Operations		Over 100 times
Temperature Range		0°C ~ 85°C
Cable Tension Force in Connected		30 N
IP Degree Protection		IP 67 (IEC 60529)
Standard		IEC 61076-2-101

M8 WIRING

2 wire QD wiring

M83M

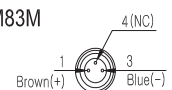

3 wire QD wiring

M83M

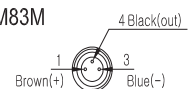

SENSOR



Particular attention must be paid not to exceed the limits list in the specification.

Otherwise, permanent damage to sensor may occur.

1. For reed switch type sensors, it must be series connected a LoAD to use, or will damage the sensor.
2. Connect the brown wire in series with LOAD to positive(+) and the blue wire to negative(-) of power source.

If the polarity be inverted, reed switch remains functional but LED will remain in "OFF" state.

Just exchange the brown and blue wires.

2 Wire standard connection

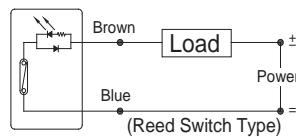

1. For solid-state type sensors, it must be used with DC power source.
2. Connect brown wire to positive(+) and the blue wire to negative(-) of DC power source.

The black wire must be connected to the LOAD only.

3. If the black wire is connected to the power source directly. permanent damage to the sensor may occur.

3 Wire standard connection

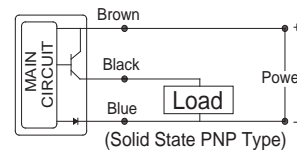
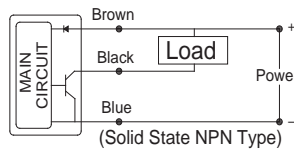

1. The external protect element is required.

If the sensor is used to switch conductive load. such as relay or solenoid valve.

2. For DC conductive load. attach an external diode parallel to the load as illustrated below.
3. For AC conductive load. use R-C circuit to parallel the load as illustrated below.

Inductive load protection

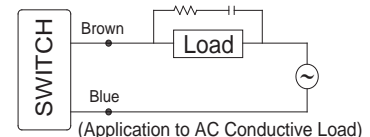
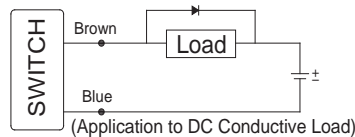

If the sensor is used to switch capacitive load or the cable length exceed 10M.

Please series a inductor (470 H ~ 2000 H) as close to the sensor to prevent damage (sticking effect).

Capacitive load protection

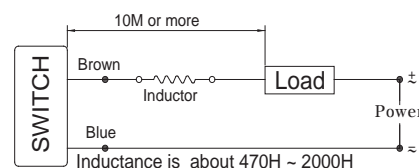

Keep sensor out of the strong magnetic field to get rid of interference.