



ENZFELDER GmbH

Power transmission
and
lifting engineering

**High performances
Spindle gears
Type HSG**

History

1969 Mr. Enzfelder established a job shop in Vienna. Equipped with some machinery, the Enzfelder Company manufactured machine parts according to drawings.

Within one year the number of employees rose to 3. The Enzfelder company started manufacturing threaded spindles and nuts according to drawings. Then the range of manufacturing was enlarged by toothed wheels, screw wheels and endless screws according to drawings.

1974 The company including the complete manufacture was relocated to Enzesfeld.

1975 The manufacture of spindle gears was launched. The company's experience in the manufacture of trapezoid-threaded spindles, nuts, worm gear pairs and casings was a valuable basis for the construction. After many tests, the serial production of spindle gears was launched one year later. The result was a product characterized by a first-rate price-performance ratio. The product was distributed by dealers all over Europe.

1981 The planning and construction of small hydropower plants was launched to replace diesel generators. Environmental protection was not really a topic at that time, however, and the production was stopped in 1986.

1989 The Enzfelder GesmbH company replaced the Franz Enzfelder Company.

1990 Scissor-type lifting platforms and cable winches were added to the delivery program.

1991 Resilient spacer shafts were tested and added to the production range. At the same time, the telescopic spindle gear was developed. A patent for this principle was applied for and issued.

1993 The sale of spindle gears under their own name was launched and presented for the first time at the Hannover industrial fair. We have been approached with a variety of tasks and have provided solutions according to the customers' needs ever since.

1994 In cooperation with our customers we produced the first bevel gears to specification.

1995 Spindle bearing arrangements were designed and included in the standard program.

1996 The Enzfelder company produced planet gear to specification for the first time.

1998-1999 The standard programs were enlarged. Additionally, bevel gears are manufactured in a standard design.

2000 The development of electric cylinders in standard design for very high loads (5-1000kN) was started. At the same time the telescopic spindle gears were refined to save the customer the guiding and locking devices. Since that time we have been able to offer telescopic cylinders, too.

2001 The development of electric cylinders was completed, and these cylinders were added to the standard program.

At the same time the development and fabrication of cubic spindle gears for lifting loads between 2.5 and 150kN was started. These gears were added to the standard program as well.

2002 were extended and optimized the series of the electric cylinders. Further we provide an electronic 2D-3D product catalogue of the spindle gears, it makes it possible to integrate our products into your system.

2002-2003 We putted our new assembling and packaging hall, beside the manufacturing hall, in operation

2003 We increased our machinery by buying a CNC machine tool with 7 axes, brand AXA. That new CNC machine allows a precise machining of the screw jack housings in only two clamping.

2003-2004 The engineering started to use new 3-D CAD software, Solid Edge. That software enables our customers to integrate easily our drawings.

2004 We opened a sales office in France.

2004-2005 We started to design the high performance screw jacks HSG and we created a range of 10 different sizes.

2005 First participation to an exhibition in France: INDUSTRIE 2005 at Lyon.

2005-2006 We started to design a new range of telescopic screw jacks TSGLR. Today, these new telescopic screw jacks, with a more compact design, are used in the stage industry, in the aircraft industry, on train lifting equipments and in machine building.

2008 We replaced the tread grinding machine by a new CNC thread grinding machine, brand Mikromat.

In the past years we solved problems of motive power engineering and lifting for our customers. We searched and found the optimal solution for each case and manufactured at the best possible price/performance ratio.

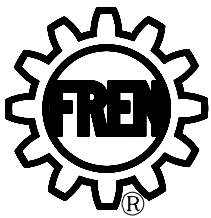

Technical Data

ENZFELDER GMBH
Power transmission- and
lifting engineering

Eichengasse 36
A-2551 Enzesfeld-Lindabrunn
Tel.: ++43 (0) 2256 81287-0
Fax: ++43 (0) 2256 81287-95
E-Mail: office@enzfelder.at
Internet: www.enzfelder.at

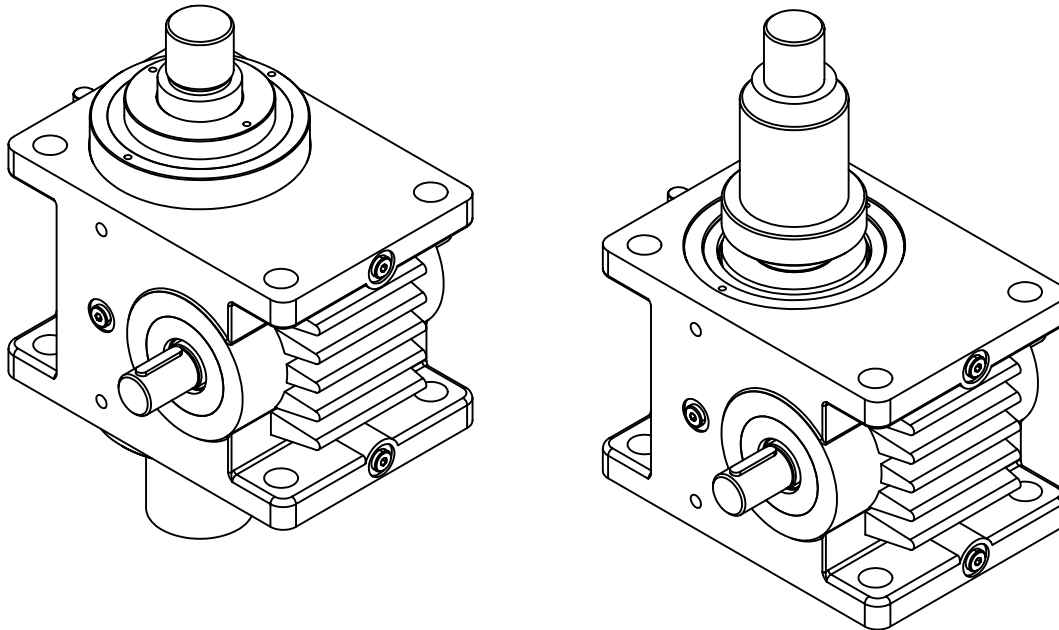

FREN high performances screw jacks are strong worm gear reducers driving a trapezoidal lifting screw. The reducer cases are made of nodular cast iron GGG40 for high loads and meeting high safety standards.

The worm hardened and ground is running on angular ball bearings. The worm wheel is made of high strength material which is particularly abrasion resistant. It is running on thrust ball bearings.

The sizes HSG 31 (force 5kN) to HSG 200 (force 1000kN) are filled with oil on delivery. The trapezoidal lifting screw can be delivered on standard as a single- start spindle or as a multi- start spindle. For higher demands on regards to lifting speed or duty cycle we use ball screws (KHS) or planetary roller spindle drives (PHSG).

Type		31	36	50	63	80	100	125	140	180	200
Max. capacity	kN	5	10	25	50	100	200	350	500	750	1000
Max. tensile force	kN	5	10	25	50	100	200	350	500	750	1000
Lifting screw		Tr 18x4	Tr 22x5	Tr 40x8	Tr 50x9	Tr 60x12	Tr 70x12	Tr 100x16	Tr 120x16	Tr 140x20	Tr 160x20
Ratio N		4:1	5:1	6:1	7:1	8:1	8:1	10 2/3:1	10 2/3:1	13 1/3:1	13 1/3:1
Raise per revolution N	mm/r	1,0	1,0	1,33	1,28	1,5	1,5	1,5	1,5	1,50	1,5
Ratio L		16:1	20:1	24:1	28:1	32:1	32:1	32:1	32:1	40:1	40:1
Raise per revolution L	mm/r	0,25	0,25	0,33	0,32	0,375	0,375	0,5	0,5	0,5	0,5
Max. input power at 20% ED/ hour	kW	0,6	0,9	1,5	2,3	3,6	4,8	7,7	10,2	12,2	17,9
Max. input power at 10% ED/ hour	kW	1	1,5	2,6	4	6,3	8,4	13,5	18	21	31
Efficiency at ratio N	%										
Efficiency at ratio L	%	on request if needed									
Lifting screw efficiency	%	42,5	43	40	36,5	39,5	35,5	34	30	32	28,5
Torque on lifting screw at max load	Nm	7,5	18,5	80	190	478	1060	2600	4235	-	1115
Max. permissible torque on input shaft	Nm	13	29,5	49	168	398	705	975	1640	-	4260
case material		Al alloy	Al alloy	GGG 40	GGG 40	GGG 40	GGG 40	GGG 40	GGG 40	GGG 40	GGG 40
Weight without spindle or protection tube	kg	2	4	13	25	47	74	145	335	-	870
Weight for each 100mm stroke	kg	0,16	0,23	0,82	1,3	1,79	2,52	5,2	7,7	10,87	13,82

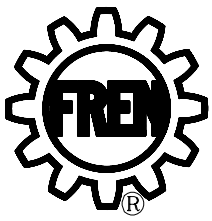

HSG dimensions translating screw version

ENZFELDER GMBH
 Power transmission- and
 lifting engineering
 Eichengasse 36
 A-2551 Enzesfeld-Lindabrunn
 Tel.: ++43 (0) 2256 81287-0
 Fax: ++43 (0) 2256 81287-95
 E-Mail: office@enzfelder.at
 Internet: www.enzfelder.at

Spindle nose 1

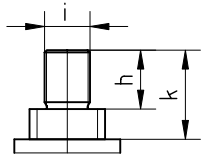

Spindle nose 2

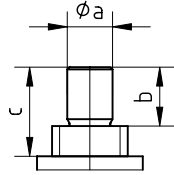

Spindle nose 3

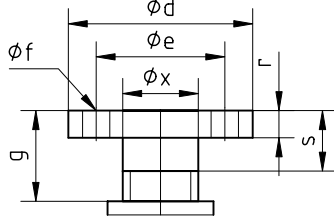

Spindle nose 4

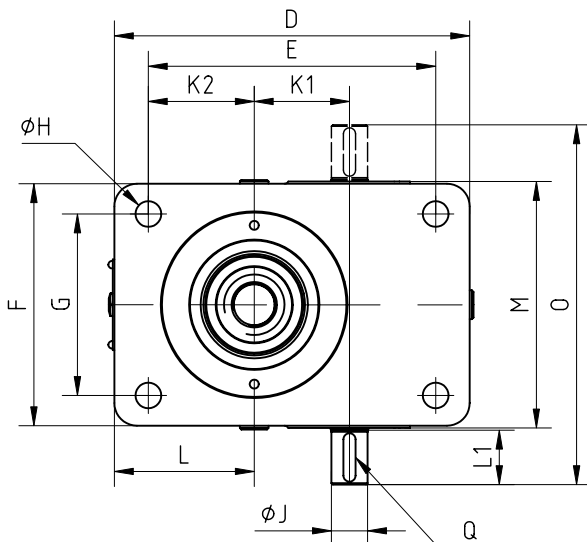
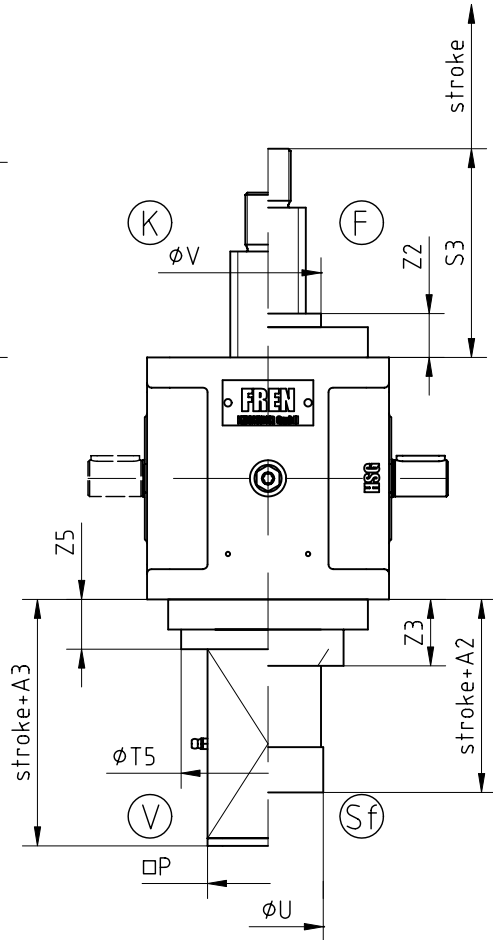
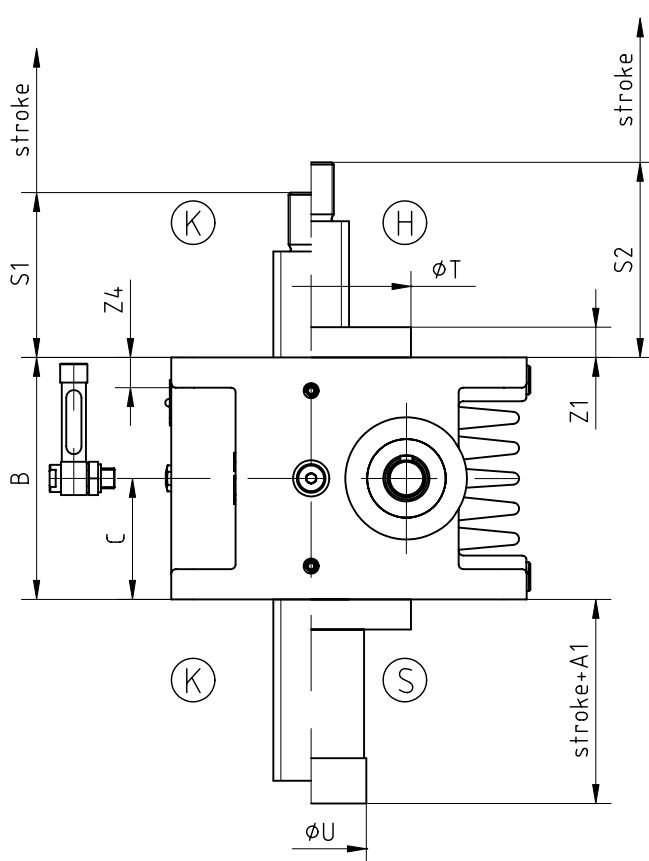
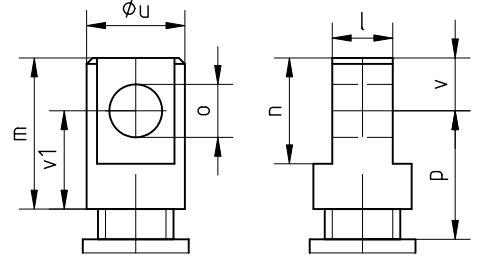

Possible executions:

- K____ Short cover
- H____ high cover
- F____ Guide
- S____ Protection tube
- Sf____ protection tube with guide
- V____ locked against rotation

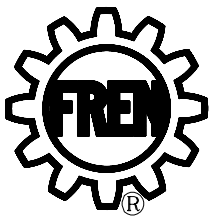

HSG dimensions translating screw version

ENZFELDER GMBH
Power transmission- and
lifting engineering
Eichengasse 36
A-2551 Enzesfeld-Lindabrunn
Tel.: ++43 (0) 2256 81287-0
Fax: ++43 (0) 2256 81287-95
E-Mail: office@enzfelder.at
Internet: www.enzfelder.at

Type	31	36	50	63	80	100	125	140	180	200
Lifting screw	Tr 18x4	Tr 22x5	Tr 40x8	Tr 50x9	Tr 60x12	Tr 70x12	Tr 100x16	Tr 120x16	Tr 140x20	Tr 160x20
A 1	22	22	22	22	22	22	22	22	22	22
A 2	39	44	46	52	61	71	76	86	-	101
A 3	98	104	117	123	136	152	154	179	-	199
B	80	105	130	160	200	230	300	350	-	450
C	40	52,5	65	80	100	15	150	175	-	225
D	117	138	175	235	275	330	410	490	-	680
E	95	110	140	190	220	270	330	390	-	550
F	80	105	130	160	200	230	300	350	-	460
G	62	80	100	120	150	175	230	260	-	330
ø H	9	9	13	17	21	28	39	46	-	66
ø J k6	10	14	16	24	32	38	42	50	-	70
K 1	31	36	50	63	80	100	125	140	-	200
K 2	31	40	50	70	75	87,5	110	130	-	185
L	42	54	67,5	92,5	102,5	117,5	150	180	-	250
L 1	15	18	28	36	58	58	82	82	-	105
M	83	108	133	163	204	235	305	355	-	470
N	86	112	136	166	206	240	310	360	-	472
O	116	148	192	238	322	356	474	524	-	682
Square P	30	40	70	80	80	100	140	180	-	220
Q	3x3x12	5x5x16	5x5x25	8x7x32	10x8x50	10x8x50	12x8x70	14x9x70	-	20x12x100
S 1	43	45	50	60	70	75	100	120	-	140
S 2	58	61	68	80	95	105	135	160	-	190
S 3	66	69	76	89	109	124	154	184	-	219
ø T f7	62	72	92	122	152	182	222	262	-	352
ø T 5	50	-	100	115	130	-	200	260	-	310
ø U	28	37	66	82	78	92	136	143	-	198
ø V	35	40	60	70	100	125	160	195	-	240
ø W	45	50	80	100	120	150	180	220	-	290
Z 1	15	16	18	20	25	30	35	40	-	50
Z 2	23	24	26	29	39	49	54	64	-	79
Z 3	29	34	39	44	54	64	74	84	-	109
Z 4	10	12	15	20	25	28	35	45	-	60
Z 5	27	-	28	33	40	-	54	63	-	73

Spindel end 1

h	17	24	29	39	49	54	79	99	-	119
i	M 12x1,5	M 16x1,5	M 20x1,5	M 30x2	M 42x3	M 56x3	M 80x3	M 100x4	M 120x4	M 140x4
k	37	44	49	59	69	74	99	119	-	139

Spindle end 2

ø a k6	12	15	20	30	40	50	80	95	-	130
b	17	24	29	39	49	54	79	99	-	119
c	37	44	49	59	69	74	99	119	-	139

Spindle end 3

ø d	62	72	92	122	150	182	222	262	-	352
ø e	45	50	65	85	105	135	170	205	-	270
ø f	4x ø6,6	4x ø9	4x ø14	4x ø18	4x ø22	6x ø26	8x ø30	8x ø33	-	8x ø45
g	43	45	50	60	70	75	100	120	-	140
r	8	10	12	18	20	25	30	35	-	50
s	48	25	30	40	50	55	80	100	-	120
ø x	20	30	35	50	65	85	115	140	-	185

Spindle end 4

l-0,2	20	25	30	40	60	75	100	120	-	160
m	50	60	70	100	130	150	230	300	-	360
n	30	40	50	70	100	120	160	200	-	280
ø o H8	15	20	25	35	50	60	80	100	-	140
p	55	60	65	85	100	110	170	220	-	240
ø u	30	40	50	65	90	110	140	170	-	220
v	15	20	25	35	50	60	80	100	-	140
v1	35	40	45	65	80	90	150	200	-	220

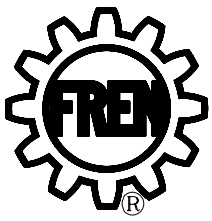

HSG dimensions Traveling nut version

ENZFELDER GMBH
Power transmission- and
lifting engineering

A-2551 Enzesfeld-Lindabrunn
Tel.: ++43 (0) 2256 81287-0
Fax: ++43 (0) 2256 81287-95
E-Mail: office@enzfelder.at
Internet: www.enzfelder.at

Spindle nose 1 Spindle nose 2

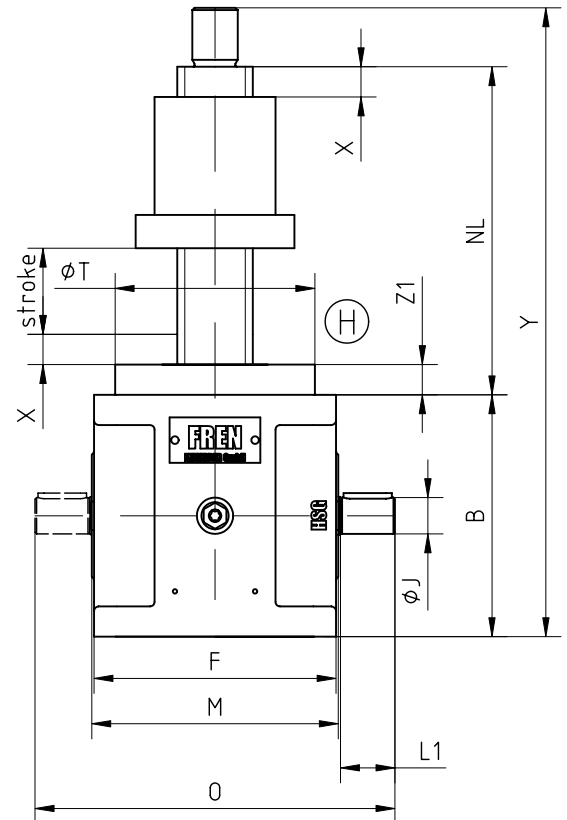
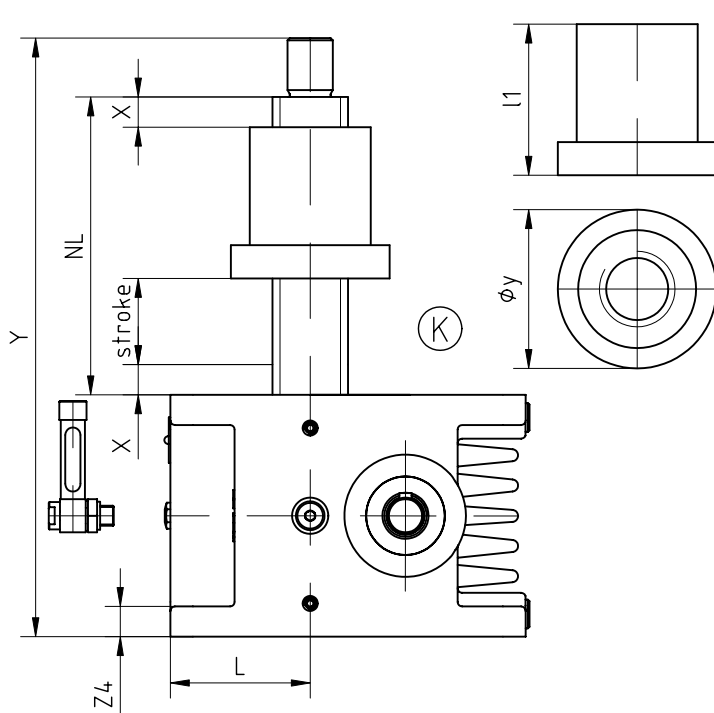
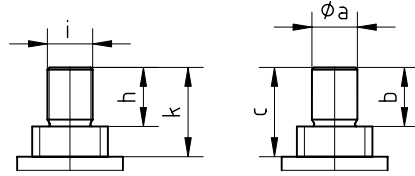

Possible executions:

K____with short cover
H____with high cover

Missing dimensions
See version with translating screw

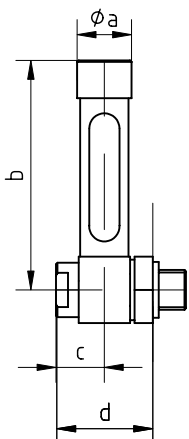

Oil gauges dimensions

Size	31	36	50	63	80	100	125	140	180	200
ø a					18	18	18	18	18	18
b	For these sizes we use an oil sight glass				80	100	125	150	200	200
c					16	16	16	16	16	16
d					33	33	33	33	33	33

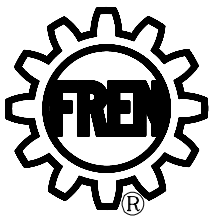

HSG dimensions

Traveling nut version

ENZFELDER GMBH
Power transmission- and
lifting engineering

A-2551 Enzesfeld-Lindabrunn
Tel.: ++43 (0) 2256 81287-0
Fax: ++43 (0) 2256 81287-95
E-Mail: office@enzfelder.at
Internet: www.enzfelder.at

Type	31	36	50	63	80	100	125	140	180	200
Lifting screw	Tr 18x4	Tr 22x5	Tr 40x8	Tr 50x9	Tr 60x12	Tr 70x12	Tr 100x16	Tr 120x16	Tr 140x20	Tr 160x20
B	80	105	130	160	200	230	300	350	-	450
C	40	52,5	65	80	100	15	150	175	-	225
F	80	105	130	160	200	230	300	350	-	460
ø J k6	10	14	16	24	32	38	42	50	-	70
L	42	54	67,5	92,5	102,5	117,5	150	180	-	250
L 1	15	18	28	36	58	58	82	82	-	105
M	83	108	133	163	204	235	305	355	-	470
NL version "K"	stroke + 85	stroke + 95	stroke + 120	stroke + 140	stroke + 170	stroke + 170	stroke + 200	stroke + 220	-	stroke + 260
NL version "H"	stroke + 100	stroke + 111	stroke + 138	stroke + 160	stroke + 195	stroke + 200	stroke + 235	stroke + 260	-	stroke + 310
O	116	148	192	238	322	356	474	524	-	682
Q	3x3x12	5x5x16	5x5x25	8x7x32	10x8x50	10x8x50	12x8x70	14x9x70	-	20x12x100
ø T f7	62	72	92	122	152	182	222	262	-	352
Safety X	20	20	20	20	20	20	20	20	20	20
Y	NL + 97	NL + 129	NL + 169	NL + 199	NL + 249	NL + 284	NL + 379	NL + 449	-	NL + 569
Z 1	15	16	18	20	25	30	35	40	-	50
Z 4	10	12	15	20	25	28	35	45	-	60

Lifting nut

I 1	45	55	80	100	130	130	160	180	-	220
I 2	35	43	62	78	105	100	115	130	-	140
ø y	50	65	87	105	110	120	190	225	-	260
ø z h9	40	45	70	80	90	90	150	160	-	200

Spindel end 1

h	17	24	29	39	49	54	79	99	-	119
i	M 12x1,5	M 16x1,5	M 20x1,5	M 30x2	M 42x3	M 56x3	M 80x3	M 100x4	M 120x4	M 140x4
k	37	44	49	59	69	74	99	119	-	139

Spindel end 2

ø a k6	12	15	20	30	40	50	80	95	-	130
b	17	24	29	39	49	54	79	99	-	119
c	37	44	49	59	69	74	99	119	-	139

Delivery programm

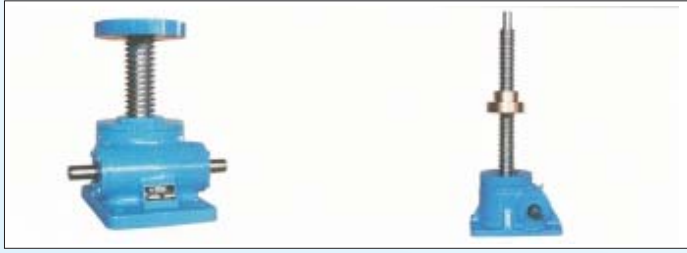

FREN Spindle gear for lifting, lowering, pulling, pushing, sluing, or rotating
Forces up to 3000kN
Lifts up to 10000mm

FREN Electric cylinders for lifting, lowering, pulling, pushing, sluing, or rotation
Forces up to 1000kN
Lifts up to 2500mm



FREN Bevel gears 'K' and Bevel gears cubic 'H' for deflecting input shafts
Speeds up to 6500U/min
Torques up to 5200Nm

FREN Resilient cardan shafts for transmitting torques with assembling inaccuracies
Angles up to 3°
Torques up to 500Nm



FREN Telescopic gears and telescopic cylinders for lifting, lowering, pulling, pushing
Forces up to 1000kN
Lifts up to 10000mm

FREN Planet gears in special designs for reducing speeds and increasing torques
Gear reduction 1,5:1 up to 1500:1
Torques up to 1000Nm



FREN Scissor-type lifting platforms for lifting and lowering including a wide range of accessories
Forces up to 500kN
Lifts up to 5000mm

FREN Cable winches for lifting, lowering, pulling or sluing
Forces up to 300kN
Lifts up to 100000mm

