

ACCESSORIES

MICRO COLLET	P 91
NEW BABY COLLET	P 92
NBC ENDMILL COLLET	P 93
COLLET EJECTOR	P 93
MEGA E COLLET	P 94
STRAIGHT COLLET for MILLING CHUCK	P 95
PERFECT SEAL (MPS / BPS / EPS)	P 96
PULL STUD BOLT	P 99
POINT MASTER PRO PMP	P101
POINT MASTER PMC	P103
POINT MASTER PMG	P104
BASE MASTER SERIES	P105
TOOL MASTER	P107
TOOLING MATE	P108
HOLDER LOCK	P108
KOMBI GRIP	P109
ST LOCK	P109
T-SLOT CLEAN	P109
α WIPER CLEANER	P110
TK CLEANER	P110
α TAPER CLEANER	P110
α TOOLING CLEANER	P111
SPINDLE CLEANER	P111
CLEAN TEC	P111



POINT MASTER PRO SERIES

POINT MASTER PRO Series is a precision 3-D touch sensor which will operate in non-conductive as well as conductive applications, Resin, ceramic or coated workpieces, machines with ceramic spindle taper or bearings can all be accommodated etc.



Touch Probe & Edge Finder

CYLINDRICAL Shank Type



For all materials, including non-conductive cutting tools, workpieces, and machine tools.

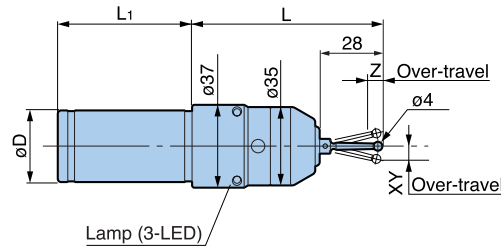

Model	øD (h7)	L	L1	Repeatability (Probe)	Over-travel		Measuring Pressure (N)		Battery	Battery life (Continuous use)	Standard Stylus	Weight (kg)
					XY	Z	XY	Z				
PMP-10	10	75	49	±1µm (2σ)	±12	5	0.4	1.5	Panasonic Lithium BR435×1	20hours	ST28-4R	0.4
-20	20	90	50						LR1×2	50hours		0.5
-32	32	80	60						0.6			

- PMP-10 have one LED only.
- Above table indicates the specification when using stylus ST28-4R.
- There is approx 5µm lag in X & Y directions and approx. 2µm lag in Z direction to illuminate LED lamp when stylus touches workpiece surface.

BBT Shank Type JIS B 6339 (BIG-PLUS)

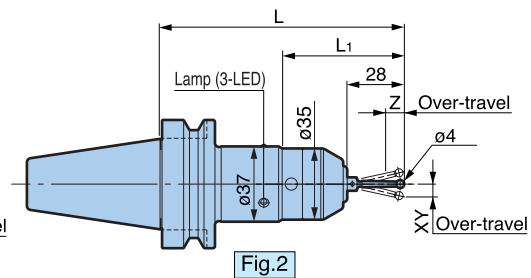
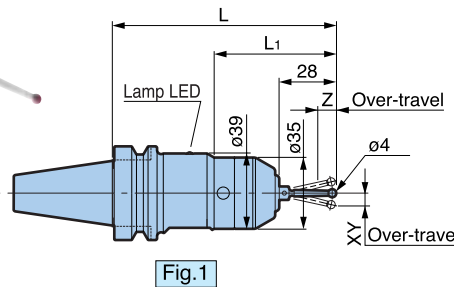

BIG-PLUS tools can be used in machining centers with conventional spindles.

Model	Fig.	BBT No.	L	L1	Repeatability (Probe)	Over-travel		Measuring Pressure (N)		Battery	Battery life (Continuous use)	Standard Stylus	Weight (kg)
						XY	Z	XY	Z				
BBT30-PMP-110	1	30	110	60	±1µm (2σ)	±12	5	0.4	1.5	SR44×2	24hours	ST28-4R	0.8
BBT40-PMP-120	2	40	120	60						LR1×2	50hours		1.3

- BBT30-PMP-110 have one LED only.
- Above table indicates the specification when using stylus ST28-4R.
- There is approx 5µm lag in X & Y directions and approx. 2µm lag in Z direction to illuminate LED lamp when stylus touches workpiece surface.

HSK Shank Type ISO12164&DIN69893-1

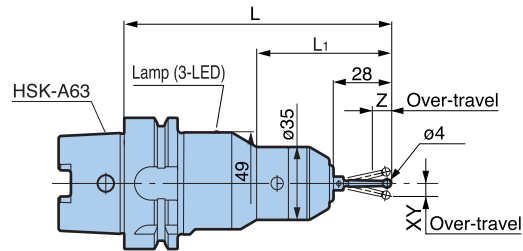

Model	HSK No.	L	L1	Repeatability (Probe)	Over-travel		Measuring Pressure (N)		Battery	Battery life (Continuous use)	Standard Stylus	Weight (kg)
					XY	Z	XY	Z				
HSK-A63-PMP-130	63	130	65	$\pm 1\mu\text{m}(2\sigma)$	± 12	5	0.4	1.5	CR2×1	24hours	ST28-4R	1.3

- Above table indicates the specification when using stylus ST28-4R.
- There is approx $5\mu\text{m}$ lag in X & Y directions and approx. $2\mu\text{m}$ lag in Z direction to illuminate LED lamp when stylus touches workpiece surface.

ALTERNATIVE STYLII

The stylus (M3 thread) is replaceable. Please replace when different model of stylus required or if damaged.

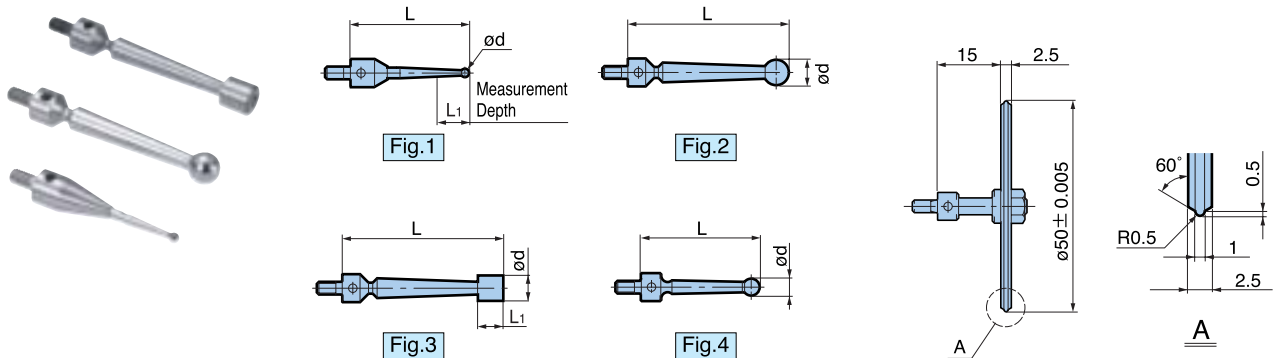

Model	Fig.	L	L1	ϕd	Material	Series	
ST28-1P	1	28	2	1	Carbide	PMG-PMC-PMP	
-2P			8	2			
-3P			4	—			3
-4P				4			
ST38-6P	2	38	—	6	Steel	PMG-PMC	
ST38-6×6	3		6	6	(SUS)	PMG□□S-PMC□□S	
ST28-4R	4	28	—	4	Ruby	PMP	

※ Stylus model ST38-6×6 is exclusive for PMG□□S and PMC□□S series.
Runout accuracy may worsen when used on PMG or series without "S".

Ideal for awkward shaped workpiece or tapered portion of plastic mold.

Model **ST15-50K**

* PMG&PMC-Series only.

POINT MASTER **PMC** SERIES

POINT MASTER Series is a precision 3-D touch sensor to center and measure the workpiece.

LED lamp illuminates when the stylus touches the workpiece.
Stroke of stylus provides sufficient over-travel for safety.



Touch Probe &
Edge Finder

CYLINDRICAL Shank Type

For use with conductive cutting tools, workpieces, and machine tools.

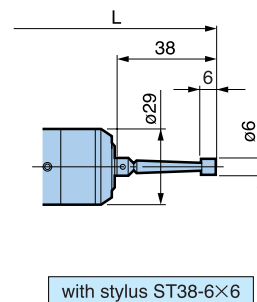
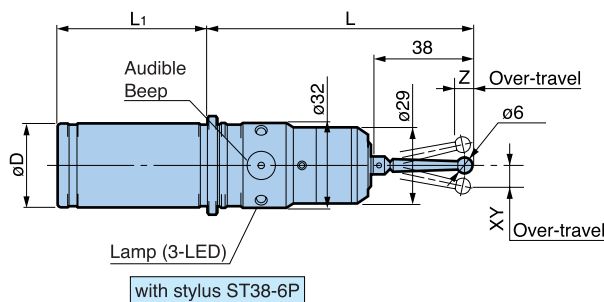

Model	øD h7	L	L1	Repeatability (Probe)	Over-travel		Measuring Pressure (N)		Battery	Battery life (Continuous use)	Standard Stylus	Weight (kg)
					XY	Z	XY	Z				
PMC-20	20	110	50	±1μm (2σ)	±12	5	0.6	3	LR1×2	33hours	ST38-6P	0.4
-32	32	102	58									0.6
PMC-20S	20	110	50	±1μm (2σ)	±12	5	0.6	3	LR1×2	33hours	ST38-6×6	0.4
-32S	32	102	58									0.6

1. ST38-6x6 cylindrical stylus is mounted on models with "S".
2. Above table indicates the specification when using standard stylus.

For stylus options:P102

BT Shank Type

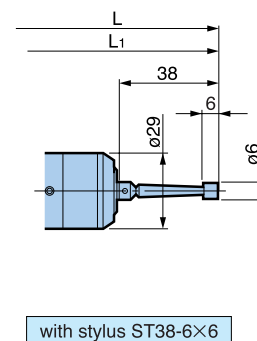
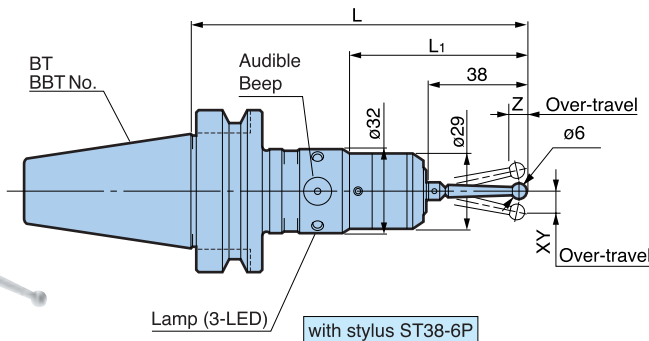

Model	BT No.	L	L1	Repeatability (Probe)	Over-travel		Measuring Pressure (N)		Battery	Battery life (Continuous use)	Standard Stylus	Weight (kg)
					XY	Z	XY	Z				
BT40-PMC-130	40	130	69	±1μm (2σ)	±12	5	0.6	3	LR1×2	33hours	ST38-6P	1.2
BT50-PMC-160	50	160										4.0
BT40-PMC-130S	40	130	69	±1μm (2σ)	±12	5	0.6	3	LR1×2	33hours	ST38-6×6	1.2
BT50-PMC-160S	50	160										4.0

1. ST38-6x6 cylindrical stylus is mounted on models with "S".
2. Above table indicates the specification when using standard stylus.

For stylus options:P102



BBT40/50 JIS B 6339 (BIG-PLUS)

BIG-PLUS tools can be used in machining centers with conventional spindles.

Model	BBT No.	L	L1	Repeatability (Probe)	Over-travel		Measuring Pressure (N)		Battery	Battery life (Continuous use)	Standard Stylus	Weight (kg)
					XY	Z	XY	Z				
BBT40-PMC-130	40	130	69	±1μm (2σ)	±12	5	0.6	3	LR1×2	33hours	ST38-6P	1.2
BBT50-PMC-160	50	160										4.0
BBT40-PMC-130S	40	130	69	±1μm (2σ)	±12	5	0.6	3	LR1×2	33hours	ST38-6×6	1.2
BBT50-PMC-160S	50	160										4.0

1. ST38-6x6 cylindrical stylus is mounted on models with "S".
2. Above table indicates the specification when using standard stylus.

For stylus options:P102

POINT MASTER PMG SERIES

LED lamp illuminates when the stylus touches the workpiece.



Touch Probe & Edge Finder

For use with conductive cutting tools, workpieces, and machine tools.

CYLINDRICAL Shank Type

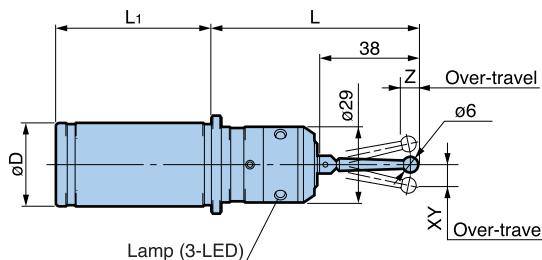

with stylus ST38-6P

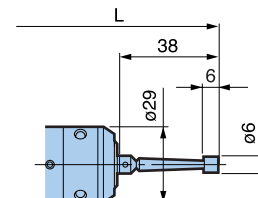

with stylus ST38-6x6

Model	øD h7	L	L1	Repeatability (Probe)	Over-travel		Measuring Pressure (N)		Battery	Battery life (Continuous use)	Standard Stylus	Weight (kg)
					XY	Z	XY	Z				
PMG-10	10	75	50	±1μm (2σ)	±12	5	0.6	3	Panasonic Lithium BR435×1	12hours	ST38-6P	0.2
-20	20	90							LR1×2	25hours		0.3
-32	32	80							60	0.5		
PMG-10S	10	75	50	±1μm (2σ)	±12	5	0.6	3	Panasonic Lithium BR435×1	12hours	ST38-6x6	0.2
-20S	20	90							LR1×2	25hours		0.3
-32S	32	80							60	0.5		

1. PMG-10 and PMG-10S have one LED only.
2. ST38-6x6 cylindrical stylus is mounted on models with "S".
3. Above table indicates the specification when using standard stylus.

For stylus options:P102

MORSE TAPER Shank Type

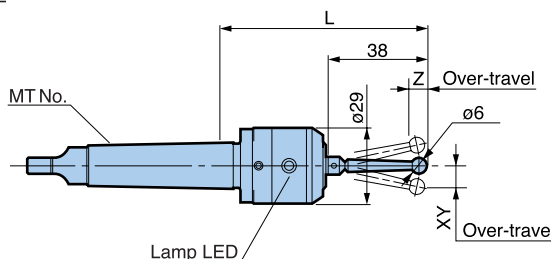

with stylus ST38-6P

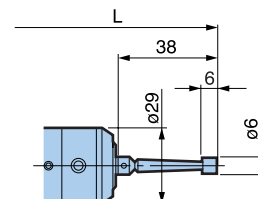

with stylus ST38-6x6

Model	MT No.	L	Repeatability (Probe)	Over-travel		Measuring Pressure (N)		Battery	Battery life (Continuous use)	Standard Stylus	Weight (kg)
				XY	Z	XY	Z				
PMG-MT2	MT2	80	±1μm (2σ)	±12	5	0.6	3	Panasonic Lithium BR435×1	12hours	ST38-6P	0.2
-MT2S										ST38-6x6	0.2

1. PMG-MT2 and PMG-MT2S have one LED only.
2. ST38-6x6 cylindrical stylus is mounted on models with "S".
3. Above table indicates the specification when using standard stylus.

For stylus options:P102

BASE MASTER SERIES

BASE MASTER Series is a precision touch sensor to determine workpiece offsets and tool length.

Mounted on workpiece surface or machine table, LED lamp illuminates immediately when the cutting edge touches the sensor plate and the position is detected.



Tool Offset Sensor

BASE MASTER

The most popular Base Master model with $\pm 1\mu\text{m}$ accuracy. Operates when a conductive circuit is completed.



For use with conductive cutting tools, workpieces, and machine tools.



Model **BM-50**

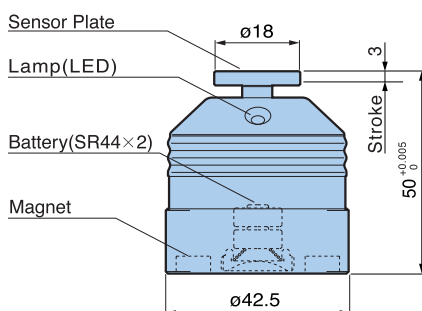

Height accuracy	$50^{+0.005}_0$ mm
Measurable pressure	3N
Repeatability accuracy	$\pm 1\mu\text{m}(2\sigma)$
Min. measurable tool diameter	$\phi 1\text{mm}$
Battery life	10hours (continuous use)
Weight	0.23kg

BASE MASTER GOLD

Suitable for various tools and workpieces, including non-conductive materials such as ceramics.



For all materials, including non-conductive cutting tools, workpieces, and machine tools.



Model **BM-50G**

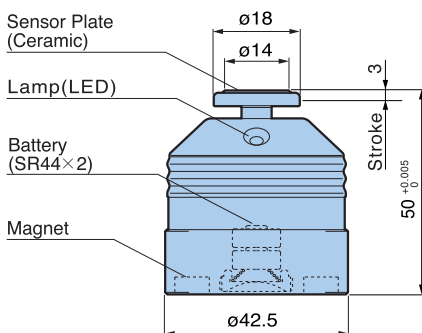

Height accuracy	$50^{+0.005}_0$ mm
Measurable pressure	3N
Repeatability accuracy	$\pm 1\mu\text{m}(2\sigma)$
Min. measurable tool diameter	$\phi 1\text{mm}$
Battery life	10hours (continuous use)
Weight	0.24kg

BASE MASTER GOLD

Suitable for various tools and workpieces, including non-conductive materials such as ceramics.



100mm detecting height. Larger measuring head eases operation.

For all materials, including non-conductive cutting tools, workpieces, and machine tools.



NEW

Model **BM-100G**

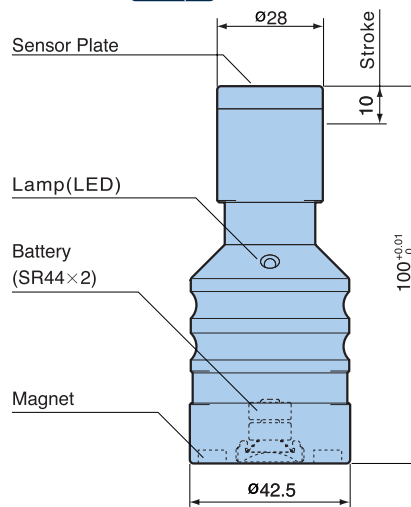

Height accuracy	100 ^{+0.01} ₀ mm
Measureable pressure	2N
Repeatability accuracy	±1μm(2σ)
Min. measurable tool diameter	ø1mm
Battery life	10hours (continuous use)
Weight	0.36kg

BASE MASTER MICRO PAT.P

Specifically designed for micro cutting tools. Low measuring pressure protects the cutting edge.



Pre-set **ø0.05mm** tools. Considerable reduction of set-up time for small dia. tools.

For all materials, including non-conductive cutting tools, workpieces, and machine tools.



Model **BM-50M**

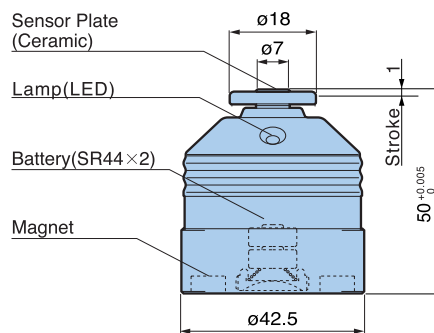

Height accuracy	50 ^{+0.005} ₀ mm
Measureable pressure	0.3N
Repeatability accuracy	±1μm(2σ)
Min. measurable tool diameter	ø0.05mm
Battery life	10hours (continuous use)
Weight	0.24kg

BASE MASTER SERIES

BASE MASTER Series is a precision touch sensor to determine workpiece offsets and tool length.

Mounted on workpiece surface or machine table, LED lamp illuminates immediately when the cutting edge touches the sensor plate and the position is detected.



Tool Offset Sensor

BASE MASTER mini

- **World smallest 20mm body diameter.**
- Best suited to measurement in complicated shapes and limited space.
- High intensity Blue LED indication when the offset position is detected.



For all materials, including non-conductive cutting tools, workpieces, and machine tools.



Protection cover with magnifier(X 5)

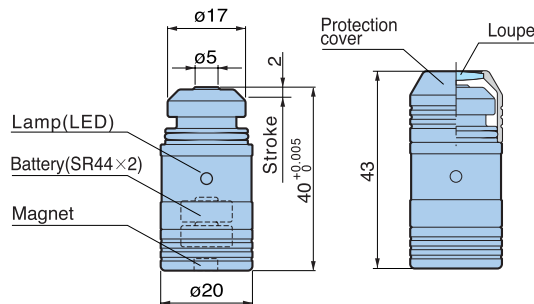

Height accuracy	40 ^{+0.005} ₀ mm
Measureable pressure	1.8N
Repeatability accuracy	±1μm(2σ)
Min. measurable tool diameter	ø0.1mm
Battery life	10hours (continuous use)
Weight	55g

Model **BMM-20**

TOOL MASTER

TOOL MASTER is a precision touch sensor with a large dial gauge. LED lamp and sound pre-indicate approach to 100mm height to ease the detecting operation.



Tool Offset Sensor



Model **TM-100**

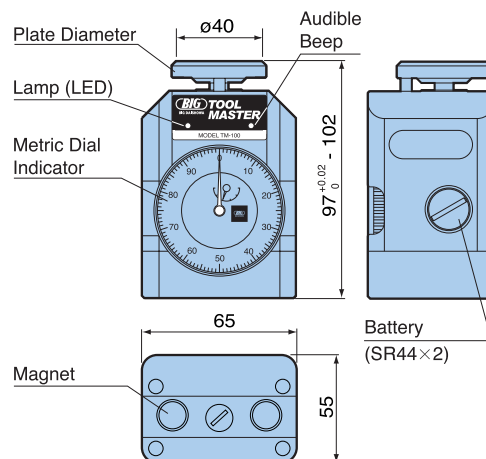

For all materials, including non-conductive cutting tools, workpieces, and machine tools.

Height accuracy	100 ^{+0.02} ₀ mm	
Stroke	5mm	
Stroke range	97 - 102mm	
Measureable pressure	6N(100mm)	
Weight	1.2kg	
Dial gauge	Graduation	0.01mm
	Indication tolerance	±15μm
	Repeatability	5μm
	Return tolerance	5μm

* Dial gauge accuracy in accordance with JISB7503:1997.